

E | S E R I E S
W I D E S C R E E N

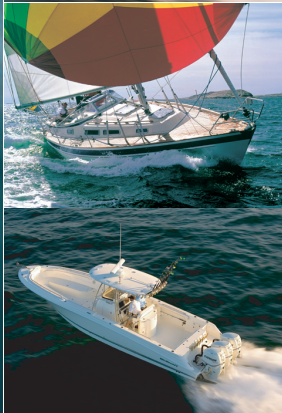

E-Series Widescreen Multifunction Display

User reference handbook

E90W, E120W and E140W models

Raymarine[®]

Trademark and patents notice

Autohelm, hsb², RayTech Navigator, Sail Pilot, SeaTalk, SeaTalk^{NG}, SeaTalk^{HS} and Sportpilot are registered trademarks of Raymarine UK Limited. RayTalk, Seahawk, Smartpilot, Pathfinder and Raymarine are registered trademarks of Raymarine Holdings Limited.

FLIR is a registered trademark of FLIR Systems, Inc. and/or its subsidiaries.

All other trademarks, trade names, or company names referenced herein are used for identification only and are the property of their respective owners.

This product is protected by patents, design patents, patents pending, or design patents pending.

Fair Use Statement

You may print no more than three copies of this manual for your own use. You may not make any further copies or distribute or use the manual in any other way including without limitation exploiting the manual commercially or giving or selling copies to third parties.

Copyright ©2010 Raymarine UK Ltd. All rights reserved.

ENGLISH

Document number: 81320-3

Date: 10-2010

Contents

| | | | |
|---|-----------|--|-----------|
| Chapter 1 Important information..... | 9 | 3.5 Hybridtouch overview | 25 |
| Safety notices..... | 9 | 3.6 Touchscreen overview | 26 |
| TFT LCD Displays | 10 | 3.7 Home screen overview | 26 |
| Water ingress..... | 10 | 3.8 Pages | 27 |
| Disclaimers | 10 | 3.9 Applications..... | 29 |
| Chart cards and memory cards..... | 11 | 3.10 Screen overview | 30 |
| EMC conformance..... | 11 | 3.11 Editing information in dialogs..... | 34 |
| Suppression ferrites..... | 11 | 3.12 Basic touchscreen operations | 34 |
| Connections to other equipment | 12 | 3.13 Databar status symbols | 35 |
| Declaration of conformity..... | 12 | 3.14 Initial setup procedures..... | 38 |
| Product disposal..... | 12 | Chapter 4 Managing display data | 43 |
| Warranty registration..... | 12 | 4.1 Memory cards overview..... | 44 |
| IMO and SOLAS..... | 12 | 4.2 Inserting a memory card, chart card, or CF / microSD card adaptor | 44 |
| Technical accuracy | 12 | 4.3 Ensure chart card door is securely closed..... | 45 |
| Chapter 2 Handbook information..... | 13 | 4.4 Removing a memory card, chart card, or CF / microSD adaptor | 45 |
| 2.1 Handbook information | 14 | 4.5 Saving user data and user settings..... | 46 |
| 2.2 Handbook conventions | 15 | 4.6 Transferring data using NMEA | 47 |
| Chapter 3 Getting started | 17 | 4.7 Resetting your system | 48 |
| 3.1 Multifunction display system integration..... | 18 | Chapter 5 Using waypoints, routes and tracks | 49 |
| 3.2 Networking constraints | 21 | 5.1 Waypoints | 50 |
| 3.3 Display power..... | 22 | | |
| 3.4 Controls..... | 23 | | |

| | | | |
|---|------------|--|------------|
| 5.2 Routes | 60 | 7.7 Autopilot alarms | 108 |
| 5.3 Tracks | 66 | Chapter 8 Using alarms and MOB functions | 109 |
| 5.4 Waypoints, routes and tracks storage capacity | 68 | 8.1 Using Man Overboard (MOB) functions | 110 |
| Chapter 6 Using the chart..... | 69 | 8.2 Alarms..... | 111 |
| 6.1 Chart application overview | 70 | Chapter 9 Using radar | 117 |
| 6.2 Vessel position and orientation | 72 | 9.1 Radar overview | 118 |
| 6.3 Chart views..... | 75 | 9.2 Digital radar scan speed | 118 |
| 6.4 Chart planning options..... | 79 | 9.3 Radar scanner status symbols | 119 |
| 6.5 Chart navigation options | 79 | 9.4 Radar range and image quality | 120 |
| 6.6 Measuring distances and bearings | 80 | 9.5 Radar display overview | 123 |
| 6.7 Chart vectors | 81 | 9.6 Dual range radar operation | 125 |
| 6.8 Current information | 82 | 9.7 Radar mode and orientation..... | 126 |
| 6.9 Tide information | 83 | 9.8 Radar tuning: HD and SuperHD digital scanners | 129 |
| 6.10 Chart object information..... | 85 | 9.9 Radar tuning: non-HD digital radomes..... | 134 |
| 6.11 Chart layers | 86 | 9.10 Using radar to measure distances, ranges, and bearings..... | 138 |
| 6.12 Chart presentation..... | 90 | 9.11 Using radar to track targets and avoid collisions | 142 |
| 6.13 Chart setup..... | 93 | 9.12 Radar setup menu options | 146 |
| Chapter 7 Using autopilot control..... | 103 | Chapter 10 Using AIS | 149 |
| 7.1 Enabling the autopilot control function | 104 | 10.1 AIS overview..... | 150 |
| 7.2 Disengaging the autopilot in an emergency | 104 | 10.2 AIS prerequisites..... | 151 |
| 7.3 Autopilot control | 105 | | |
| 7.4 Autopilot control options | 106 | | |
| 7.5 Autopilot dialog box..... | 106 | | |
| 7.6 Autopilot status symbols | 107 | | |

| | | | |
|--|------------|---|------------|
| 10.3 Classes of AIS data..... | 152 | 12.7 Fishfinder waypoints..... | 183 |
| 10.4 Enabling AIS..... | 153 | 12.8 Fishfinder alarms..... | 183 |
| 10.5 Displaying AIS vectors..... | 153 | 12.9 Fishfinder setup | 184 |
| 10.6 AIS status symbols..... | 154 | Chapter 13 Using the engine application | 191 |
| 10.7 AIS silent mode..... | 154 | 13.1 Engine application overview..... | 192 |
| 10.8 Viewing AIS target information | 155 | 13.2 Displaying the engine application | 192 |
| 10.9 Using AIS to avoid collisions | 156 | 13.3 Setting up the engine application..... | 193 |
| 10.10 AIS options | 157 | 13.4 Changing the engine panel dial color | 193 |
| 10.11 AIS alarms | 158 | 13.5 Pre-configured data panels | 194 |
| 10.12 Buddy tracking | 159 | 13.6 Changing what the engine application displays | 196 |
| 10.13 Aid to Navigation (AToN) targets..... | 161 | Chapter 14 Using the data application | 197 |
| 10.14 Land base station targets..... | 162 | 14.1 Data application overview | 198 |
| Chapter 11 Using the Course Deviation Indicator | 165 | 14.2 Pre-configured data panels | 199 |
| 11.1 Course Deviation Indicator overview..... | 166 | 14.3 Trim tab calibration..... | 202 |
| 11.2 Displaying the CDI application..... | 167 | 14.4 Customizing the data application..... | 202 |
| 11.3 Using the CDI application..... | 167 | Chapter 15 Using the weather application (North America only)..... | 205 |
| Chapter 12 Using the fishfinder | 169 | 15.1 Weather application overview..... | 206 |
| 12.1 Fishfinder introduction | 170 | 15.2 Displaying the weather application..... | 206 |
| 12.2 The sonar image..... | 171 | 15.3 Weather application setup..... | 207 |
| 12.3 Fishfinder presets..... | 173 | 15.4 Weather application display overview | 207 |
| 12.4 Fishfinder display modes | 174 | 15.5 Weather map navigation | 211 |
| 12.5 Fishfinder range | 177 | 15.6 Weather reports | 211 |
| 12.6 Fishfinder presentation options..... | 178 | | |

| | |
|--|------------|
| 15.7 Storm tracking..... | 212 |
| 15.8 Animated weather graphics..... | 213 |
| Chapter 16 Using Sirius satellite radio (North America only)..... | 215 |
| 16.1 Sirius radio overview | 216 |
| 16.2 Displaying the Sirius radio application..... | 216 |
| 16.3 Sirius radio basic operations | 217 |
| 16.4 Sirius radio presets..... | 218 |
| 16.5 Favorite Sirius radio song alerts | 219 |
| 16.6 Sirius radio parental locking | 220 |
| Chapter 17 Using Navtex | 221 |
| 17.1 Navtex overview..... | 222 |
| 17.2 Navtex setup..... | 222 |
| 17.3 Viewing and managing Navtex messages | 223 |
| Chapter 18 Using video..... | 225 |
| 18.1 Video application overview..... | 226 |
| 18.2 Using video..... | 227 |
| Chapter 19 Using the thermal camera application..... | 229 |
| 19.1 Thermal camera application overview | 230 |
| 19.2 Camera control | 231 |
| 19.3 Image adjustments | 233 |
| 19.4 Camera setup | 236 |

| | |
|--|------------|
| Chapter 20 DSC VHF radio integration..... | 237 |
| 20.1 Using a DSC VHF radio with your display | 238 |
| 20.2 Enabling DSC VHF radio integration..... | 239 |
| Chapter 21 Customizing your display | 241 |
| 21.1 Customizing the vessel icon..... | 242 |
| 21.2 Customizing the databar | 242 |
| 21.3 GPS setup | 243 |
| 21.4 System setup menu..... | 245 |
| Chapter 22 Maintaining your display..... | 253 |
| 22.1 Service and maintenance | 254 |
| 22.2 Routine equipment checks | 254 |
| 22.3 Cleaning | 255 |
| 22.4 Cleaning the display case | 255 |
| 22.5 Cleaning the display screen | 256 |
| Chapter 23 Technical support | 257 |
| 23.1 Raymarine customer support | 258 |
| 23.2 3rd party support..... | 259 |

Chapter 1: Important information

Safety notices



Warning: Ensure safe navigation

This product is intended only as an aid to navigation and must never be used in preference to sound navigational judgment. Only official government charts and notices to mariners contain all the current information needed for safe navigation, and the captain is responsible for their prudent use. It is the user's responsibility to use official government charts, notices to mariners, caution and proper navigational skill when operating this or any other Raymarine product.



Warning: Product installation and operation

This product must be installed and operated in accordance with the instructions provided. Failure to do so could result in personal injury, damage to your boat and/or poor product performance.



Warning: High voltages

This product contains high voltages. Do NOT remove any covers or otherwise attempt to access internal components, unless specifically instructed in this document.



Warning: Touchscreen display

When exposed to prolonged periods of direct sunlight, the touchscreen display can get very hot. In such conditions, avoid using the touchscreen display and use the unit's physical keys and buttons instead.



Warning: Autopilot control

The autopilot functions available on the multifunction display do NOT replace the autopilot control head. You must have a pilot control head installed before you enable or engage the autopilot.



Warning: Sonar operation

- NEVER operate the sounder with the boat out of the water.
- NEVER touch the transducer face when the sounder is powered on.
- SWITCH OFF the sounder if divers are likely to be within 7.6 m (25 ft) of the transducer.



Warning: Radar scanner safety

Before rotating the radar scanner, ensure all personnel are clear.



Warning: Radar transmission safety

The radar scanner transmits electromagnetic energy. Ensure all personnel are clear of the scanner when the radar is transmitting.

Caution: Care of chart cards

To avoid irreparable damage to and/or loss of data from chart cards:

- Ensure that chart cards are fitted the correct way around. DO NOT try to force a card into position.
- DO NOT save data (waypoints, routes, and so on) to a chart card, as the charts may be overwritten.
- DO NOT use a metallic instrument such as a screwdriver or pliers to remove a chart card.
- Safe removal. Use the Remove Card menu option before removing the chart card.

Caution: Ensure chart card door is securely closed

To prevent water ingress and consequent damage to the display, ensure that the chart card door is firmly closed. This can be confirmed by an audible click.

Caution: Cleaning

When cleaning this product:

- Do NOT wipe the display screen with a dry cloth, as this could scratch the screen coating.
- Do NOT use abrasive, or acid or ammonia based products.
- Do NOT use a jet wash.

TFT LCD Displays

The colors of the display may seem to vary when viewed against a colored background or in colored light. This is a perfectly normal effect that can be seen with all color Liquid Crystal Displays (LCDs).

In common with all Thin Film Transistor (TFT) LCD units, the screen may exhibit a few (less than 7) wrongly illuminated pixels. These may appear as black pixels in a light area of the screen or as colored pixels in black areas.

Water ingress

Water ingress disclaimer

Although the waterproof rating capacity of Raymarine products exceeds that called for by the IPX6 standard, water intrusion and subsequent equipment failure may occur if any Raymarine equipment is subjected to commercial high pressure washing. Raymarine will not warrant equipment subjected to high pressure washing.

Disclaimers

This product (including the electronic charts) is intended to be used only as an aid to navigation. It is designed to facilitate use of official government charts, not replace them. Only official government charts and notices to mariners contain all the current information needed for safe navigation, and the captain is responsible for their prudent use. It is the user's responsibility to use official government charts, notices to mariners, caution and proper navigational skill when operating this or any other Raymarine product. This product supports electronic charts provided by third party data suppliers which may be embedded or stored on memory card. Use of such

charts is subject to the supplier's End-User Licence Agreement included in the documentation for this product or supplied with the memory card (as applicable).

Raymarine does not warrant that this product is error-free or that it is compatible with products manufactured by any person or entity other than Raymarine.

This product uses digital chart data, and electronic information from the Global Positioning System (GPS) which may contain errors. Raymarine does not warrant the accuracy of such information and you are advised that errors in such information may cause the product to malfunction. Raymarine is not responsible for damages or injuries caused by your use or inability to use the product, by the interaction of the product with products manufactured by others, or by errors in chart data or information utilized by the product and supplied by third parties.

Chart cards and memory cards

Compatible cards

The following types of memory or chart card are compatible with your Raymarine system:

- CompactFlash (CF)
- micro Secure Digital (microSD)
- micro Secure Digital High-Capacity (microSDHC)

Note: microSD and microSDHC cards require the optional Raymarine CF / microSD card adaptor. Only the official Raymarine adaptor is compatible with your system.

Chart cards

Your system is pre-loaded with electronic charts for your region. If you wish to use different chart data, you can insert compatible CF chart cards into the CompactFlash card slot on your unit. If you

want to use microSD or microSDHC chart cards, you must purchase the optional CF / microSD card adaptor and insert it into the CompactFlash card slot on your unit. The microSD or microSDHC chart card must be inserted into the adaptor.

Use branded chart cards and memory cards

When archiving data, Raymarine recommends the use of quality branded memory cards. Some brands of memory card may not work in your unit. Please contact customer support for a list of recommended cards.

EMC conformance

Raymarine equipment and accessories conform to the appropriate Electromagnetic Compatibility (EMC) regulations for use in the recreational marine environment.

Correct installation is required to ensure that EMC performance is not compromised.

Suppression ferrites

Raymarine cables may be fitted with suppression ferrites. These are important for correct EMC performance. If a ferrite has to be removed for any purpose (e.g. installation or maintenance), it must be replaced in the original position before the product is used.

Use only ferrites of the correct type, supplied by Raymarine authorized dealers.

Connections to other equipment

Requirement for ferrites on non-Raymarine cables

If your Raymarine equipment is to be connected to other equipment using a cable not supplied by Raymarine, a suppression ferrite **MUST** always be attached to the cable near the Raymarine unit.

Declaration of conformity

Raymarine Ltd. declares that G-Series systems are in compliance with the essential requirements of EMC directive 2004/108/EC.

The original Declaration of Conformity certificate may be viewed on the relevant product page at www.raymarine.com

Product disposal

Dispose of this product in accordance with the WEEE Directive.



■ The Waste Electrical and Electronic Equipment (WEEE) Directive requires the recycling of waste electrical and electronic equipment. Whilst the WEEE Directive does not apply to some Raymarine products, we support its policy and ask you to be aware of how to dispose of this product.

Warranty registration

To register your Raymarine product ownership, please take a few minutes to fill out the warranty registration card found in the box, or visit www.raymarine.com and register on-line.

It is important that you register your product to receive full warranty benefits. Your unit package includes a bar code label indicating the serial number of the unit. You should stick this label to the warranty registration card.

IMO and SOLAS

The equipment described within this document is intended for use on leisure marine boats and workboats not covered by International Maritime Organization (IMO) and Safety of Life at Sea (SOLAS) Carriage Regulations.

Technical accuracy

To the best of our knowledge, the information in this document was correct at the time it was produced. However, Raymarine cannot accept liability for any inaccuracies or omissions it may contain. In addition, our policy of continuous product improvement may change specifications without notice. As a result, Raymarine cannot accept liability for any differences between the product and this document.

Chapter 2: Handbook information

Chapter contents

- [2.1 Handbook information on page 14](#)
- [2.2 Handbook conventions on page 15](#)

2.1 Handbook information

This handbook contains important information regarding the E-Series Widescreen range of multifunction displays.

The handbook is for use with the following models:

- E90W Widescreen Multifunction Display
- E120W Widescreen Multifunction Display
- E140W Widescreen Multifunction Display

About this handbook

This handbook describes how to operate your multifunction display in conjunction with compatible electronic cartography and peripheral equipment.

It assumes that all peripheral equipment to be operated with it is compatible and has been correctly installed. This handbook is intended for users of varying marine abilities, but assumes a general level of knowledge of display use, nautical terminology and practices.

E-Series handbooks

The E-Series Widescreen Multifunction Display has the following handbooks available:

All documents are available to download as PDFs from www.raymarine.com

E-Series handbooks

| Description | Part number |
|---|-------------|
| Installation and commissioning instructions | 87116 |
| Operating instructions (quick reference) | 86137 |
| User reference handbook | 81320 |

Additional handbooks

| Description | Part number |
|---------------------------------------|-------------|
| SeaTalk [®] reference manual | 81300 |

2.2 Handbook conventions

Conventions used in this handbook.

The following conventions are used throughout this handbook when referring to:

- **Softkeys** — the term "select" is used in procedures involving softkeys to refer to the action of selecting a softkey, either using touch or by pressing the corresponding physical key.
- **Menus** — the term "select" is used in procedures involving menus to refer to the action of selecting an item, either by touch or with physical keys and buttons.

Chapter 3: Getting started

Chapter contents

- [3.1 Multifunction display system integration on page 18](#)
- [3.2 Networking constraints on page 21](#)
- [3.3 Display power on page 22](#)
- [3.4 Controls on page 23](#)
- [3.5 Hybridtouch overview on page 25](#)
- [3.6 Touchscreen overview on page 26](#)
- [3.7 Home screen overview on page 26](#)
- [3.8 Pages on page 27](#)
- [3.9 Applications on page 29](#)
- [3.10 Screen overview on page 30](#)
- [3.11 Editing information in dialogs on page 34](#)
- [3.12 Basic touchscreen operations on page 34](#)
- [3.13 Databar status symbols on page 35](#)
- [3.14 Initial setup procedures on page 38](#)

3.1 Multifunction display system integration

You can connect a number of external devices to your multifunction display, providing additional features and functions.

The following diagram illustrates the various external devices that can be connected to your multifunction display:

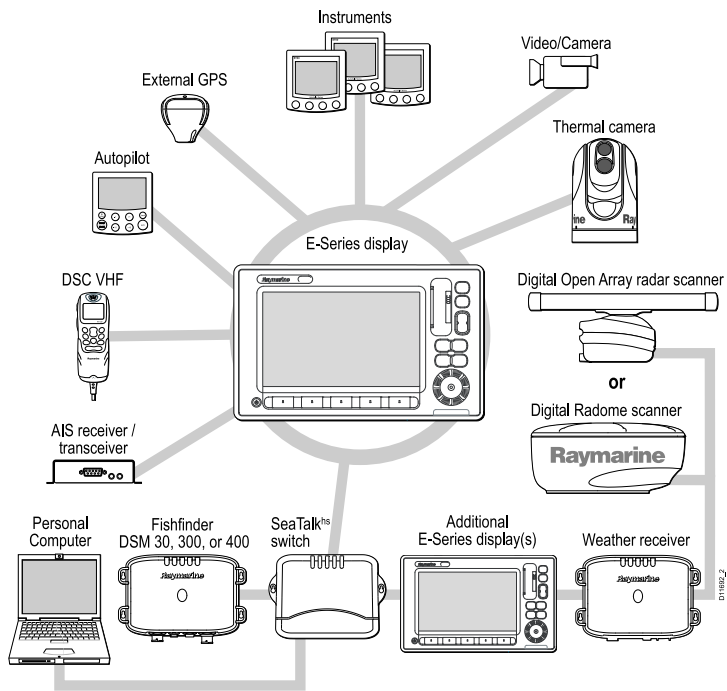

Your multifunction display uses a number of protocols to transfer data between the various devices in your networked system. The following table details which devices may be connected to your display, and the type of connectivity (in terms of protocols and physical interfaces):

| Device Type | Suitable Devices | Connectivity |
|-------------|--|-----------------------|
| Radar | <p>Up to two Raymarine radar scanners may be connected to your multifunction display, but only one may be operated at any one time.</p> <ul style="list-style-type: none"> • 4 kilowatt Digital Radome Scanner. • 4 kilowatt HD Digital Radome Scanner. • 4 kilowatt HD Digital Open Array Scanner. • 12 kilowatt HD Digital Open Array Scanner. • 4 kilowatt SuperHD Digital Open Array Scanner. • 12 kilowatt SuperHD Digital Open Array Scanner. <div style="border: 1px solid black; padding: 5px; margin-top: 10px;"> <p>Note: Please ensure your radar scanner is using the latest software version.</p> </div> | SeaTalk ^{hs} |
| Fishfinder | The E-Series Widescreen display supports the connection | SeaTalk ^{hs} |

| Device Type | Suitable Devices | Connectivity |
|------------------------|--|--|
| | <p>of ONE of the following Raymarine fishfinders:</p> <ul style="list-style-type: none"> • DSM 30 • DSM 300 • DSM 400 | |
| Cartography — included | Embedded (internal) Navionics cartography | Internal storage |
| Cartography — optional | <p>External CompactFlash, microSD, or microSDHC chart cards:</p> <ul style="list-style-type: none"> • Navionics Silver • Navionics Gold • Navionics Gold+ • Navionics Platinum • Navionics Platinum+ • Navionics Fish'N Chip • Navionics Hotmaps <p>Refer to the Raymarine website (www.raymarine.com) for the latest list of supported chart cards.</p> | <p>Card slot</p> <div style="border: 1px solid black; padding: 5px; margin-top: 10px;"> <p>Note: microSD and microSDHC cards require the optional Raymarine CF / microSD card adaptor. Only the official Raymarine adaptor is compatible with your system.</p> </div> |
| Sirius Weather/Audio | <ul style="list-style-type: none"> • Raymarine SR100 Sirius Weather Receiver | SeaTalk ^{hs} |

| Device Type | Suitable Devices | Connectivity |
|-------------------------------------|--|--|
| AIS | The E-Series Widescreen display supports the connection of ONE of the following AIS units: <ul style="list-style-type: none"> • Raymarine AIS 250 • Raymarine AIS 500 • Third-party AIS Class A or Class B receiver / transceiver | NMEA 0183 or SeaTalk ^{ng} |
| Navtex | Navtex Receiver | NMEA 0183 |
| Fast Heading Sensor | Fast Heading Sensor | NMEA 0183 |
| GPS — external | Raystar125 GPS or third-party external GPS receiver | SeaTalk, SeaTalk ^{ng} , or NMEA 0183 |
| Instruments | All current Raymarine instruments | SeaTalk, SeaTalk ^{ng} , or NMEA 0183 |
| Autopilot — Raymarine | All current Raymarine autopilots | SeaTalk, SeaTalk ^{ng} |
| Autopilot — third party | Third-party autopilots | NMEA 0183 (waypoint and bearing information) |
| VHF radio | Raymarine DSC VHF radios | NMEA 0183, SeaTalk |
| Additional multifunction display(s) | E90W, E120W, E140W, G-Series displays. | SeaTalk, SeaTalk ^{hs} , SeaTalk ^{ng} |

| Device Type | Suitable Devices | Connectivity |
|----------------|---|--|
| Thermal camera | The E-Series Widescreen display supports the connection of ONE of the following Raymarine thermal cameras: <ul style="list-style-type: none"> • T300 thermal camera (9 Hz) • T303 thermal camera (30 Hz) • T350 thermal camera (9 Hz) • T400 thermal camera (9 Hz) • T403 thermal camera (30 Hz) • T450 thermal camera (9 Hz) | SeaTalk ^{hs} (for control), BNC connector (for video) |
| Video / camera | Composite or S-Video PAL or NTSC video source | BNC connector |

3.2 Networking constraints

The following constraints apply when networking an E-Series Widescreen display with a G-Series system.

General

- E-Series Widescreen displays must be connected to the G-Series system via SeaTalk^{hs}.
- E-Series Widescreen displays can be connected via NMEA 0183.
- E-Series Widescreen displays must NOT be connected to SeaTalk^{ng} when part of a G-Series network.
- E-Series Widescreen displays must NOT be connected to SeaTalk when part of a G-Series network.

Master / slave operation

- When using an E-Series Widescreen display in a G-Series system, the G-Series GPM processor unit is ALWAYS the data master.

Nav stations

An E-Series Widescreen display can NOT form part of a G-Series Nav Station configuration.

Home screen sharing

- For networks featuring ONLY E-Series Widescreen units:
 - Networked E-Series Widescreen units share home screens.
- For networks featuring ONLY G-Series GPM processor units:
 - Networked GPM processor units share home screens.
- For networks featuring E-Series Widescreen AND G-Series GPM processor units:
 - E-Series Widescreen units share home screens.
 - GPM processor units share home screens.

- E-Series Widescreen units do NOT share home screens with GPM processor units.

Cartography sharing

- Chart card cartography is shared between E-Series Widescreen displays and G-Series GPM processor units.
- Embedded cartography can NOT be shared between E-Series Widescreen displays and G-Series GPM processor units.
- An E-Series Widescreen display will share its embedded cartography with another E-Series Widescreen display on the same network.
- A G-Series GPM processor unit will share its embedded cartography with other G-Series GPM processor units on the same network.
- The cartography contained on chart cards is always used in preference to embedded cartography when a chart card is inserted into a card slot.

Radar operation

- The G-Series system supports the use of 2 radar scanners at the same time.
- An E-Series Widescreen display in a G-Series system can operate 1 scanner at any one time. To use the second scanner you must select it in the Radar application's Setup Menu. This does not automatically power down the first scanner. When 2 scanners are connected you can power-down the second scanner at any time using the radar power controls, accessible from the display's power button.
- The rotating scanner icon in the status bar indicates the status of all connected scanners, not just the currently selected scanner. Similarly, if you have a G-Series Compact keyboard connected to an E-Series Widescreen display the radar status LED located on the keyboard reflects the status of ALL scanners.

Keyboards

If a SeaTalk^{ng} keyboard is being used to control an E-Series Widescreen display it must be connected directly to the E-Series Widescreen display using SeaTalk^{ng}. It must NOT be connected to the G-Series SeaTalk^{ng} bus.

GPS

A networked system does NOT support multiple GPS receivers.

3.3 Display power

Powering the display on

1. Press and hold the **POWER** button until the Raymarine logo appears.
2. Press **OK** to acknowledge the warning window.

Powering the display off

1. Press and hold the **POWER** button until the countdown reaches zero.

Note: If the **POWER** button is released before the countdown reaches zero, the power off is cancelled.

3.4 Controls

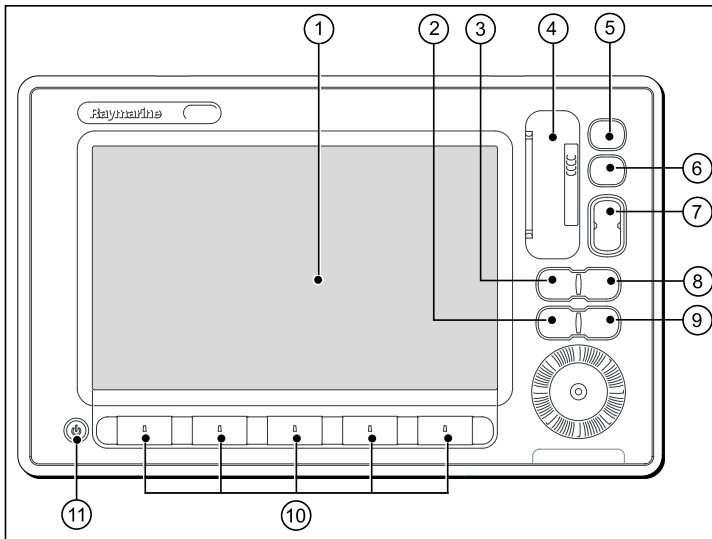

| Screen item | Description |
|-------------|---|
| 1 | Touchscreen — you can touch the screen to operate many common functions, including all softkey and menu operations. |
| 2 | Menu — accesses the setup menus. |
| 3 | Active — selects the active application in page layouts that display more than one application. Press and hold the Active button to expand the active application to a full-screen view. |

| Screen item | Description |
|-------------|---|
| 4 | Chart card slot — open the card reader door to insert or remove CompactFlash (CF) cards. CF cards are used for additional cartography, archiving waypoint, route, and track data, and upgrading system software. |
| 5 | Home — displays the home screen, where you can access all the application pages and your waypoint, track, and route data. |
| 6 | WPTS/MOB — press and release to show the waypoint softkeys. Press again to place a waypoint at your vessel's position. Press and hold to place a Man Overboard (MOB) marker at your current position. |
| 7 | Range — changes the display scale so that a smaller or larger area can be seen on the screen. |
| 8 | Data — accesses the archive and transfer, and databar options. |
| 9 | Cancel — press to return to a previous softkey, menu, or dialog level. |
| 10 | Softkeys — press to select the corresponding function identified by the on-screen label. |
| 11 | Power — press once to switch the unit ON. Once the unit is powered on, press the Power button again to adjust the brightness, and access the scanner power controls. Press and hold to switch the unit OFF. |

UniControl

The UniControl provides a number of key functions in a single control.

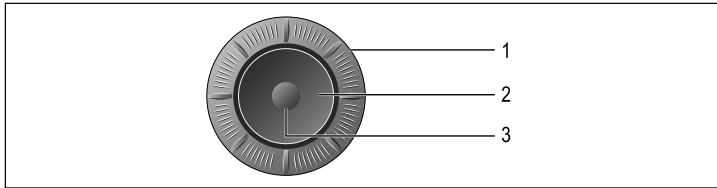

1. **Rotary Control.** Use this to select menu options and adjust the value of various items.
2. **Trackpad.** Use this to select menu items, options and move the cursor.
3. **OK button.** Use this to confirm a selection or entry.

Using buttons and softkeys

You can control your multifunction display using the various buttons and softkeys on the unit.

| | |
|--|---|
| | Buttons are used to access system functions or change what you see on-screen. |
| | Softkeys are used to select frequently-used options. The range of softkeys available at any one time depends on the context — for example, the application or function in use. Touching a softkey label on-screen selects the softkey. You can also press the corresponding physical key on the unit. |

Note: To disable the audible "beep" that you hear when a button or softkey is pressed, go to **Menu > Display Setup > Key Beep.**

Touch icons

You can use the **BACK** and **CLOSE** icons to move between the different levels of softkeys available in each application.

| | |
|--|---|
| | Back — go back one level (same effect as CANCEL button). |
| | Close — return to the top level of softkeys (that is, the initial range of softkeys shown when an application is first started). |

Using the cursor

The cursor is used to move around the screen:

| | |
|--|---|
| | The cursor appears on the screen as a white cross. |
| | If the cursor has not been moved for a short period of time, it changes to a circle with a cross in it, to make it easier to locate on the screen. |
| | The cursor is context-sensitive. When it is placed over an object such as a waypoint or chart feature, it changes color and a label or information associated with the object is displayed. When you place the cursor over certain items, the softkeys change to provide related options. |

List of cursor labels

| Label | Feature | Application |
|---------|---------------------------|--------------|
| A/B | Ruler line | Chart |
| AIS | AIS target | Chart |
| COG | Course Over Ground vector | Chart |
| CTR | Center of radar | Radar |
| FLT | Floating EBL/VRM | Radar |
| GRD | Guard zone | Radar |
| HDG | Heading vector | Chart |
| MARPA | MARPA target | Radar |
| MOB | Man Over Board marker | Chart, Radar |
| POS | Vessel's position | Chart |
| RTE | Route leg | Chart |
| SHM | Ship's Heading Marker | Radar |
| TIDE | Tide indicator | Chart |
| TRACK | Track line | Chart |
| VRM/EBL | VRM and EBL, 1 or 2 | Radar |
| WIND | Wind indicator | Chart |
| WPT | Waypoint | Chart, Radar |

3.5 Hybridtouch overview

Your multifunction display features Hybridtouch, which enables you to operate the unit using the touchscreen and the physical keys.

Many common functions can be accessed using the touchscreen - for example, all softkey operations. However, there are some functions that cannot be performed using the touchscreen. There may also be situations (such as rough sea conditions) when it is not appropriate to use the touchscreen. In these situations, Raymarine strongly recommends that you enable the touch lock, and use the physical keys to operate your multifunction display.

3.6 Touchscreen overview

The touchscreen provides a quick way of performing many common functions.

Some of the functions you can operate with the touchscreen include:

- Accessing applications.
- Adding and editing applications pages.
- Placing and editing waypoints.
- Building routes.
- Panning the chart display.
- Placing and moving the cursor.
- Placing and moving VRMs and EBLs.

Note: Raymarine strongly recommends that you familiarize yourself with touch operations while your vessel is anchored or moored. You may find it helpful to use the simulator mode (accessible from **Menu > System Setup Menu**) in these situations.

Note: To disable the audible “beep” that you hear when you touch the screen, go to **Menu > Display Setup > Touch beep**.

3.7 Home screen overview

The home screen provides a central point of access to your display's range of applications.

It also provides quick access to your waypoints, routes, and tracks.

Press the **HOME** button at any time to access the home screen.

The home screen consists of a number of application "pages", each represented by an icon. Applications can be started by selecting the relevant page icon.

Use the **MORE** softkeys to scroll the home screen and access additional application pages.

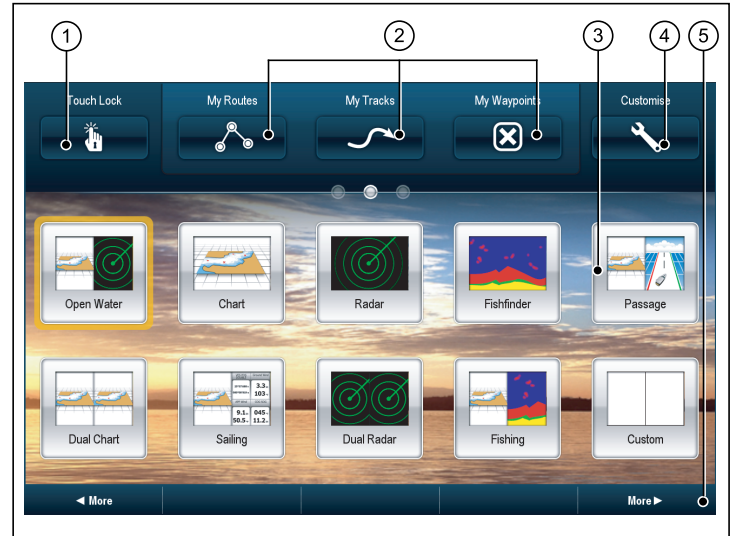



| Screen item | Description |
|-------------|---|
| 1 | Touch Lock — select this icon to lock the touchscreen, preventing accidental use. To unlock, use the UniControl to deselect the Touch Lock icon. |
| 2 | My Routes / My Tracks / My Waypoints — these icons enable you to centrally manage your lists of routes, tracks, and waypoints. |
| 3 | Page — each icon represents a page. A page can display up to 4 applications simultaneously. |
| 4 | Customize — select this icon to configure application pages. |
| 5 | More — select this softkey to scroll the home screen and access additional application pages. |

3.8 Pages

Pages are used on your multifunction display to show applications. Pages are displayed and accessed on the home screen. Each page can display between 1 and 4 applications.

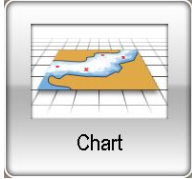
Any page on the home screen can be customized, enabling you to group your applications into different pages, each designed for a specific purpose. For example, you could have a page that includes the chart and fishfinder applications, suitable for fishing, and another page that includes the chart and data applications, which would be suitable for general sailing.

| | |
|--|---|
|  | Empty page. You can add any application(s) to any empty page. |
|  | Page featuring a single application. |
|  | Page featuring multiple applications. |

You can also define a "layout" for each page, which determines how the applications are arranged on the screen.

Multiple applications

With most applications, it is possible to run 4 instances of the same application at any one time. However there are 2 exceptions to this, which are:

- **Chart application** — maximum 2 simultaneous instances per multifunction display.
- **Sirius satellite radio application** — maximum 1 instance per multifunction display, at any one time.
- **Video application** — maximum 1 instance per multifunction display, at any one time.

Moving a page on the home screen

With the home screen displayed:

1. Select the **Customize** icon.
2. Select the page icon that you want to move.
3. Select the **SWAP PAGE** softkey.
4. Select the page icon that you want to swap positions with.
5. Press the **HOME** button to return to the home screen featuring the new icon positions.

Changing an existing page on the home screen

With the home screen displayed:

1. Select the **Customize** icon.
2. Select the page icon that you want to change.
3. Select the **EDIT PAGE** softkey.
4. Select the appropriate page layout.
5. Select the application(s) you want to display on the page.

Adding a new page to the home screen

With the home screen displayed:

1. Use the **MORE** softkey to scroll to a home screen that has space for new page icons.
2. Select the **Customize** icon.
A number of empty page icons appear.
3. Select an empty page icon.
4. Select the **EDIT PAGE** softkey.
5. Select the appropriate page layout.
6. Select the application(s) you want to display on the page.

Renaming a page on the home screen

With the home screen displayed:

1. Select the **Customize** icon.
2. Select the page that you want to rename.
3. Select the **RENAME PAGE** softkey.
The on-screen keyboard is displayed.
4. Using the on-screen keyboard, enter the new name for the page.
5. Select **SAVE**.

Deleting a page from the home screen

With the home screen displayed:



1. Select the **CUSTOMIZE** icon.
2. Select an existing page.
3. Select the **DELETE PAGE** softkey.
4. Select **YES** to confirm deletion, or **NO** to cancel the operation.



Resetting the home screen to default settings

With the home screen displayed:

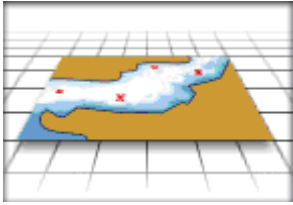
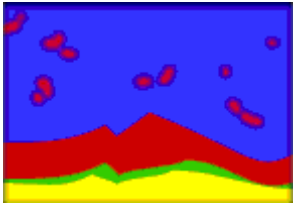
1. Select the **Customize** icon.
2. Select the **RESET ALL PAGES TO DEFAULT** softkey.
3. Select the **YES** softkey to reset the pages, or **NO** to cancel.

3.9 Applications

| | |
|---|--|
|  | <p>Chart application — provides a 2D or 3D graphical view of your charts to help you navigate. Waypoint, route, and track functions enable you to navigate to a specific location, build and navigate routes, or record where you've been. Upgrade your charts using chart cards to enjoy higher levels of detail and 3D views.</p> |
|  | <p>Fishfinder application — with a suitable Digital Sounder Module (DSM) and transducer, you can use the fishfinder application to help you accurately distinguish between different sizes of fish, bottom structure, and underwater obstacles. You can also view sea depth and temperature data, and mark points of interest, such as fishing spots or wrecks.</p> |
|  | <p>Radar application — with a suitable radar scanner, you can use the radar application to track targets and measure distances and bearings. A number of automatic gain presets and color modes are provided to help you get the best performance from your radar scanner.</p> |
|  | <p>Engine application — enables you to view engine information in the form of gauges and digital data, from up to 3 compatible engines.</p> |

| | | | | | | | | | | | | | | | | | | | | | | | | | |
|--|--|--------------|--------------|---------|-------------|-------|-------|-------|--------------|-------|--|--|----------|---------|----------|-------|-------|-------|--------|--------|--------|--------|--|--|--|
|  <table border="1"><tr><td>VIS POS</td><td>Ground Wind</td><td>VMG Waypoint</td><td>Heading</td></tr><tr><td>25°17'00.0"</td><td>3.3..</td><td>4.6..</td><td>048..</td></tr><tr><td>080°08'00.0"</td><td>103..</td><td></td><td></td></tr><tr><td>APP Wind</td><td>COG SOG</td><td>VMG Wind</td><td>Speed</td></tr><tr><td>9.1..</td><td>045..</td><td>11.1..</td><td>13.8..</td></tr><tr><td>50.5..</td><td>11.2..</td><td></td><td></td></tr></table> | VIS POS | Ground Wind | VMG Waypoint | Heading | 25°17'00.0" | 3.3.. | 4.6.. | 048.. | 080°08'00.0" | 103.. | | | APP Wind | COG SOG | VMG Wind | Speed | 9.1.. | 045.. | 11.1.. | 13.8.. | 50.5.. | 11.2.. | | | <p>Data application — view system and instrument data on your multifunction display, for a range of compatible instruments.</p> |
| VIS POS | Ground Wind | VMG Waypoint | Heading | | | | | | | | | | | | | | | | | | | | | | |
| 25°17'00.0" | 3.3.. | 4.6.. | 048.. | | | | | | | | | | | | | | | | | | | | | | |
| 080°08'00.0" | 103.. | | | | | | | | | | | | | | | | | | | | | | | | |
| APP Wind | COG SOG | VMG Wind | Speed | | | | | | | | | | | | | | | | | | | | | | |
| 9.1.. | 045.. | 11.1.. | 13.8.. | | | | | | | | | | | | | | | | | | | | | | |
| 50.5.. | 11.2.. | | | | | | | | | | | | | | | | | | | | | | | | |
|  | <p>Course Deviation Indicator (CDI) application — provides a graphical representation of your vessel's course in a "rolling road" format, along with navigation data.</p> | | | | | | | | | | | | | | | | | | | | | | | | |
|  | <p>Sirius audio application — (North America only). Use your multifunction display to control a connected Sirius Satellite Radio receiver.</p> | | | | | | | | | | | | | | | | | | | | | | | | |

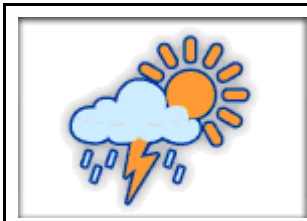

Weather application — (North America only). With a suitable weather receiver connected to your system, the weather application overlays historical, live, and forecasted weather graphics on a world map.



Video application — view a video or camera source on your multifunction display. With the appropriate optional accessories, you can connect additional video sources and switch between them.

3.10 Screen overview

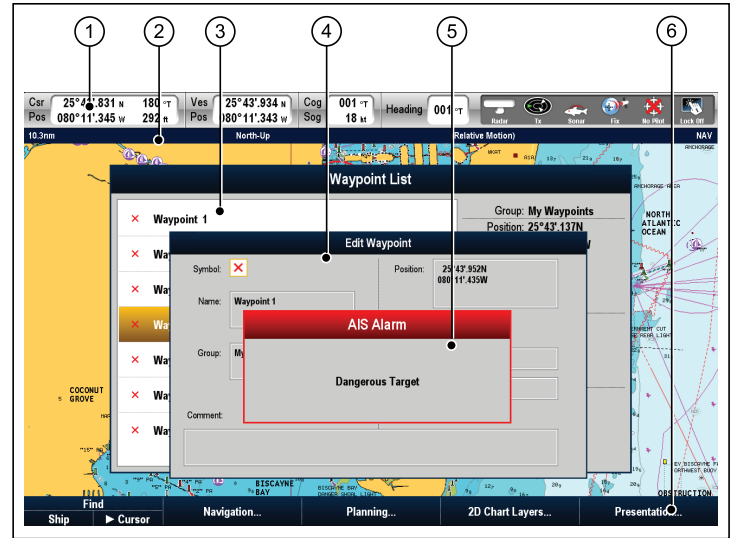

| Screen item | Description |
|-------------|---|
| 1 | Databar — provides information about your vessel and its environment. The position and type of information in the databar can be customized if required. The databar also displays the status icons, which confirm the status of externally-connected equipment, including GPS, AIS, radar, and autopilot units. |
| 2 | Status bar — provides information specific to each application. This information cannot be edited or moved. |
| 3 | List dialogs — include information you have added to your multifunction display, such as waypoints. |

| Screen item | Description |
|-------------|---|
| 4 | Edit dialogs — enable data to be edited or entered into a list — for example, editing a waypoint.. |
| 5 | Pop-up messages — alert you to a situation (such as an alarm), or unavailable function. Pop-up messages may require a response from you — for example, press the ACKNOWLEDGE softkey to silence alarms. |
| 6 | Softkeys — used to select frequently-used options. |

Using menus

Menus enable you to configure your system to your particular needs.

The following diagram shows the main features of a standard menu:

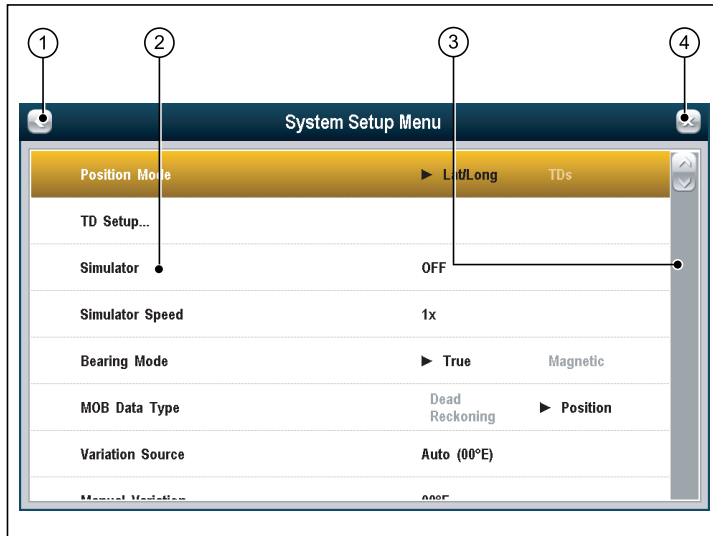

| Screen item | Description |
|-------------|--|
| 1 | Back — select this icon to go back to a previous menu. |
| 2 | Menu item — momentarily touching a menu item highlights and automatically selects the item. You can also use the trackpad or rotary control to highlight an item, and the OK button to select it. To scroll a menu, touch a menu item and hold your finger down on the item while dragging your finger up or down. You can also use the trackpad or rotary control to scroll the list. |
| 3 | Scroll bar — indicates your position in the list. You can also touch and drag the scroll bar to scroll the list. |
| 4 | Close — select this icon to close the menu(s). |

Using list dialogs

List dialogs enable you to view details of data items stored on your multifunction display, such as waypoints, routes, and tracks.

The following diagram shows the main features of a typical list dialog:

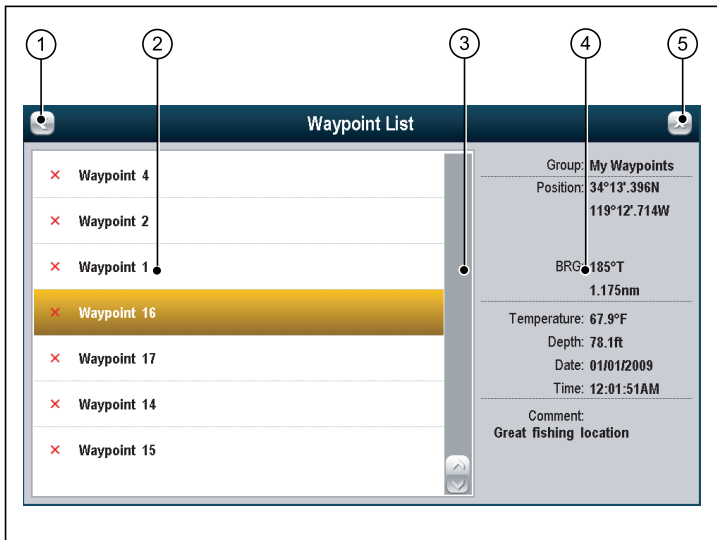

| Screen item | Description |
|-------------|---|
| 1 | Back — select this icon to go back to a previous dialog. |
| 2 | List item — touching a list item highlights it and displays the associated details. You can also use the trackpad or rotary control to highlight the list item. To scroll a list, touch a list item and hold your finger down on the item while dragging your finger up or down. You can also use the trackpad or rotary control to scroll the list. |
| 3 | Scroll bar — indicates your position in the list. You can also touch and drag the scroll bar to scroll the list. |
| 4 | Details — displays the details of the currently selected list item. |
| 5 | Close — select this icon to close the dialog(s). |

Using edit dialogs

Edit dialogs enable you to edit the details of data items stored on your multifunction display, such as waypoints, routes, and tracks.

The following diagram shows the main features of a typical edit dialog:

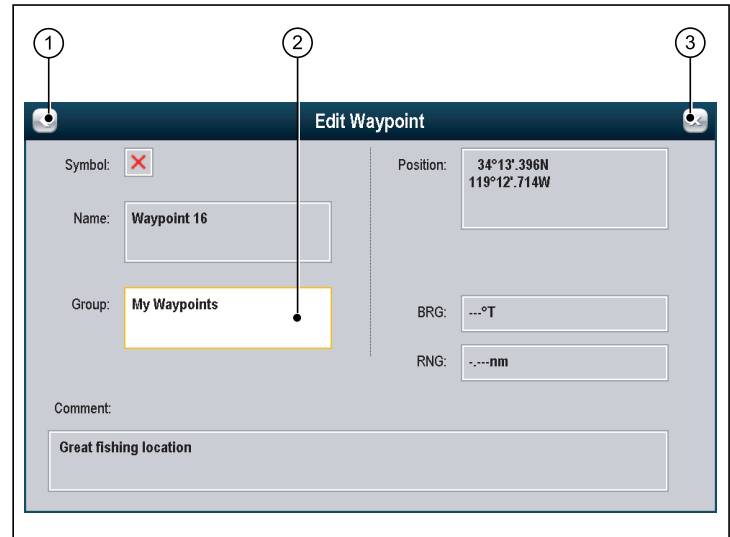

| Screen item | Description |
|-------------|---|
| 1 | Back — select this icon to go back to a previous dialog. |
| 2 | Field — touching a text field automatically displays the on-screen keyboard, which can be used to edit the details. For numeric fields, the on-screen keyboard is displayed when you select the field and the EDIT USING KEYPAD softkey. You can also use the trackpad or rotary control to highlight a field, and then the OK button or "EDIT..." softkey to display the on-screen keyboard. |
| 3 | Close — select this icon to close the dialog(s). |

Using control dialogs

Control dialogs enable you to control externally connected equipment, such as an autopilot unit.

The following diagram shows the main features of a typical control dialog:

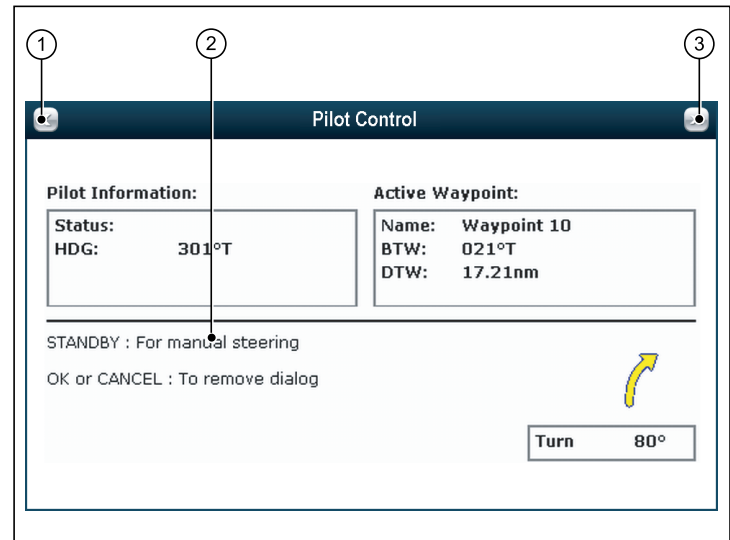

| Screen item | Description |
|-------------|--|
| 1 | Back — select this icon to go back to a previous dialog. |
| 2 | Instructions — tell you what softkeys to use for controlling the externally connected equipment. For safety reasons, it may not be possible to control certain functions using the touchscreen. In these situations, use the physical keys and buttons instead. |
| 3 | Close — select this icon to close the dialog(s). |

3.11 Editing information in dialogs

With the dialog displayed:

1. Select the field you want to edit.

The on-screen keyboard is displayed:

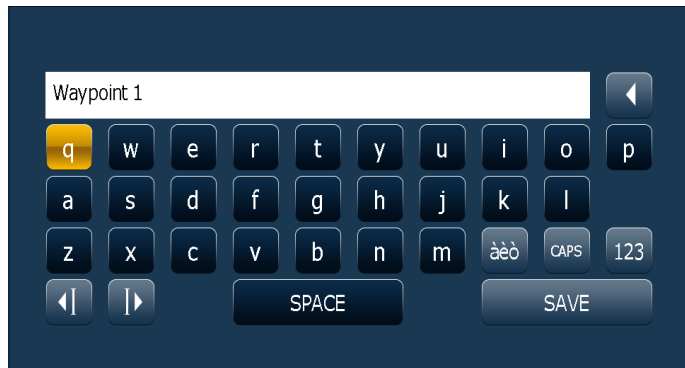

2. Use the on-screen keyboard to make the changes.
3. Use the on-screen keyboard's **SAVE** key to keep any changes.

Entering special or accented characters

With the on-screen keyboard displayed:

1. Select the on-screen keyboard's **àèò** key.
2. Select the character you want to accent.

The available accented characters are displayed above the text entry field.

3. For characters that have multiple available accents, use the character key to toggle between them.
4. Select the **àèò** key to enter the character.

3.12 Basic touchscreen operations

Placing and moving the cursor using touch

1. Touch the screen at any position on the screen to place the cursor there.

Selecting the active window using touch

With a page featuring multiple applications displayed:



1. Tap anywhere inside the application you want to make active.
A green border appears around the application, indicating that it is active. The softkeys will change to display the relevant options for that application.

Touchscreen lock

You can lock the touchscreen to prevent accidental use.

For example, locking the touchscreen is particularly useful in rough water or weather conditions.

The touchscreen is locked from the home screen. An icon in the home screen indicates the lock status:

| | |
|---|---|
|  | Touchscreen is unlocked. |
|  | Touchscreen is locked. All functions remain available using the buttons and softkeys. |

You must use the UniControl to unlock the touchscreen.

Locking the touchscreen

With the home screen displayed:

1. Select the **Touch Lock** icon.

It changes color to indicate that the touchscreen is disabled. All functions are still available using the buttons and softkeys.

Unlocking the touchscreen



With the home screen displayed:

1. Use the UniControl to highlight the **Touch Lock** icon.
2. Press the **OK** button.

The Touchscreen is enabled.

Touchscreen lock status symbols

The touchscreen lock status is indicated in the databar.

| Symbol | Description |
|---|--|
|  | The touchscreen is unlocked. |
|  | The touchscreen is locked. All functions remain available using the physical buttons and softkeys. |

3.13 Databar status symbols



The status symbols on the databar confirm whether the appropriate connections to your system have been made.



The symbols show the status for the following:

- Radar scanner.
- AIS receiver / transceiver.
- Sonar (DSM).
- GPS receiver.
- Autopilot.

Radar scanner status symbols

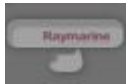

The radar scanner power mode status is indicated in the databar.





| Symbol | Radar power mode | Description |
|---|------------------|--|
|  | Transmit (TX) | Rotating icon, signifying that the scanner is on and transmitting. When SCANNER is set to ON, select this mode to activate the scanner. This is the usual mode of operation. |
|  | Standby (STBY) | Static icon, indicating that the scanner is on but not transmitting, and the antenna is not rotating. The scanner does not transmit and the radar data is removed from the screen. This is a power-save mode used when the radar is not needed for short time periods. When you return to transmit mode, the magnetron does not need to warm up again. This is the default mode. |

| Symbol | Radar power mode | Description |
|--|------------------|--|
|  | Off | Scanner powered off when radar not required, but display is in use for other applications, such as the chart. When selected, the system counts down. During this time you cannot re-power the scanner. |
|  | Timed Transmit | Scanner switches between on/transmitting, and standby mode. Scanner goes into power save mode when constant use of radar is not required. |

AIS status symbols



AIS status is indicated by a symbol in the databar.

| Symbol | Description |
|--|---|
|  | AIS unit is switched on and operating. |
|  | AIS currently unavailable. |
|  | AIS unit is switched off, or not connected. |

| Symbol | Description |
|---|--|
|  | AIS unit is in Silent Mode. |
|  | AIS unit is in Silent Mode, with active alarms. |
|  | AIS unit is connected and switched on, but has active alarms. |
|  | AIS unit is connected and switched on, but the dangerous and lost alarm is disabled. |



Sonar status symbols

The sonar (DSM) status is indicated in the databar.

| Symbol | Description |
|---|--|
|  | Symbol animated: the DSM is connected and transmitting. |
|  | Symbol static: the DSM is connected but not transmitting. |
|  | Symbol greyed-out: the DSM is not connected, or is not detected. |





GPS status symbols







The GPS receiver status is indicated in the databar.

| Symbol | Description |
|---|--|
|  | A GPS receiver is connected and has obtained a fix. |
|  | A GPS receiver is not connected, or cannot obtain a fix. |

Autopilot status symbols



The autopilot status is indicated in the databar.

| Symbol | Description |
|--|-------------------------------|
|  | Autopilot is in Standby mode. |
|  | Autopilot is in Track mode. |
|  | Autopilot is in Auto mode. |
|  | No autopilot detected. |

| Symbol | Description |
|--|---------------------------|
|  | Autopilot alarm active. |
|  | Dodge mode is active. |
|  | Fish mode is active. |
|  | Autopilot calibration. |
|  | Power steering active. |
|  | Wind Vane mode is active. |

Touchscreen lock status symbols

The touchscreen lock status is indicated in the databar.

| Symbol | Description |
|--|--|
|  | The touchscreen is unlocked. |
|  | The touchscreen is locked. All functions remain available using the physical buttons and softkeys. |

3.14 Initial setup procedures

A number of tasks should be completed before you use your display for the first time.

Once your display has been installed and commissioned (see Installation Guide), Raymarine recommends that you:

- Set the language, the date and time format and preferred units of measurement.
- Set your vessel details.
- Adjust the display brightness.
- Align the touchscreen.
- Designate the data master.
- Select the GPS data source.
- Familiarize yourself with the Simulator Mode.

Setting the language, time / date, and units of measurement

1. Press the **MENU** button.
2. Select **System Setup**.
3. Select **Language**.
4. Select the appropriate language from the list.
5. Select **Time / Date Setup**.
6. Use the **Date Format** and **Time Format** menu items to adjust the date and time.
7. Use the **Cancel** button to return to the System Setup menu.
8. Select **Units Setup**.
9. Make the appropriate changes using the menu items in the Units Setup Menu.

Setting your vessel details

1. Press the **MENU** button.

2. Select **System Setup**.
3. Select **Boat Details**.
4. Change the Safe Depth, Safe Height and Safe Width settings as appropriate for your vessel.

Note: The settings you specify for your vessel details are essential for the accurate operation of the collision alarm. You must specify vessel detail settings that are appropriate for safe navigation.

Note: The collision alarm uses data from the GPS antenna in its calculations. Therefore the values you specify for your vessel detail settings must reflect the actual position of the GPS antenna on your vessel. For example, the "Safe Width" setting is actually the diameter either side of the GPS antenna, so if you have a vessel 4 meters wide and you enter a minimum "Safe Width" of 4 meters, this is actually providing a collision zone of only 2 meters either side of the GPS antenna. If the GPS antenna is mounted on the port side of the vessel and you specified a Safe Width of 4 meters, you would be leaving 2 meters of the hull uncovered by the collision zone.

Adjusting the display brightness

1. Press the **POWER** button once.
The Backlight Level control is displayed.
2. Using the rotary control, adjust the brightness level as appropriate.
3. To switch the color palette between Day (very bright) and Night (dark) modes, select **MENU > Display Setup > Palette**.

Touchscreen alignment

If the touchscreen is misaligned to your touch, you can realign it to improve the accuracy.

Realignment involves a simple exercise to align an on-screen object with your touch. For best results, perform this exercise when your vessel is anchored or moored.



Aligning the touchscreen

1. Press the **MENU** button.
2. Select **Display Setup**.
3. Select **Touchscreen Alignment**.
4. Place your finger over the on-screen object momentarily, then remove it.
The on-screen object moves.
5. Place your finger over the on-screen object momentarily, then remove it.

6. If the operation was successful, an “Alignment Completed” message is displayed. Press the **HOME** button to return to the home screen.
7. If the operation was unsuccessful, an “Alignment Failed” message is displayed, and the Display Setup Menu is shown. Repeat steps 3 to 5.

Data master

Any system containing more than one networked multifunction display must have a designated data master.

The data master is the display which serves as a primary source of data for all displays, it also handles all external sources of information. For example the displays may require heading information from the autopilot and GPS systems, usually received through a SeaTalk^{ng} or NMEA connection. The data master is the display to which the SeaTalk, NMEA and any other data connections are made, it then bridges the data to the SeaTalk^{hs} network and any compatible repeat displays. Information shared by the data master includes:

- Cartography
- Routes and waypoints
- Radar
- Sonar
- Data received from the autopilot, instruments, the engine and other external sources.

Your system may be wired for redundancy with data connections made to repeat displays. However these connections will only become active in the event of a fault and/or reassignment of the data master.

Designating the data master

The following task must be performed on the multifunction display that you want to designate as the data master:

1. Press the **MENU** button.
2. Select the System Setup menu item.
3. Select the System Integration menu item.
4. Select the Data Master > ON option.
5. Press the **OK** button.

Selecting the GPS data source

1. Press the **MENU** button.
2. Select **System Setup**.
3. Select **System Integration**.
4. Select **Preferred GPS Source**.
5. Select the type of data input that is supplying your preferred source of GPS data (SeaTalk^{ng}/NMEA2000, SeaTalk1, or NMEA0183).

Simulator mode

The Simulator mode enables you to practice operating your display without data from a GPS antenna, radar scanner, AIS unit, or fishfinder.

The simulator mode is switched on/off in the **System Setup Menu**.

You can also adjust the vessel speed in simulator mode. This is useful for quickly moving to different areas of the chart, for example.

Note: Raymarine recommends that you do NOT use the simulator mode whilst navigating.

Note: The simulator will NOT display any real data, including any safety messages (such as those received from AIS units).

Note: Any system settings made whilst in Simulator mode are not transmitted via SeaTalk to other equipment.

Enabling the simulator mode

1. Press **Menu**.
2. Select the **System Setup** menu.
3. Select the **Simulator** item, and change its value to **On**.

Adjusting the simulator vessel speed

1. Press the **MENU** button.
2. Select **System Setup**.
3. Select **Simulator Speed**.
4. Select the appropriate speed.

Chapter 4: Managing display data

Chapter contents

- 4.1 Memory cards overview on page 44
- 4.2 Inserting a memory card, chart card, or CF / microSD card adaptor on page 44
- 4.3 Ensure chart card door is securely closed on page 45
- 4.4 Removing a memory card, chart card, or CF / microSD adaptor on page 45
- 4.5 Saving user data and user settings on page 46
- 4.6 Transferring data using NMEA on page 47
- 4.7 Resetting your system on page 48

4.1 Memory cards overview

You can use memory cards to archive data such as waypoints, routes, and tracks.

Memory cards can be used to archive your data when the system capacity is reached. You can then delete old data from your system, creating capacity for new data. The archived data can be retrieved at any time. You can also use memory cards to backup your data.

Note: Raymarine recommends that you backup your data to a memory card on a regular basis.

4.2 Inserting a memory card, chart card, or CF / microSD card adaptor

1. Check that you are using the correct type of card or card adaptor.
2. Open the chart card door, located on the front right of the display.
3. Insert the card or CF / microSD card adaptor, as shown in the diagram below, with the lip of the card or adaptor facing outwards. It should position easily. If it does not, DO NOT force it, check the direction in which the lip is facing.
4. Gently press the card or adaptor all the way in to the card slot.
5. If using a microSD card, gently insert it into the adaptor, using the correct orientation.
6. To prevent the ingress of water and consequent damage, close the chart card door and press firmly until a click is heard.

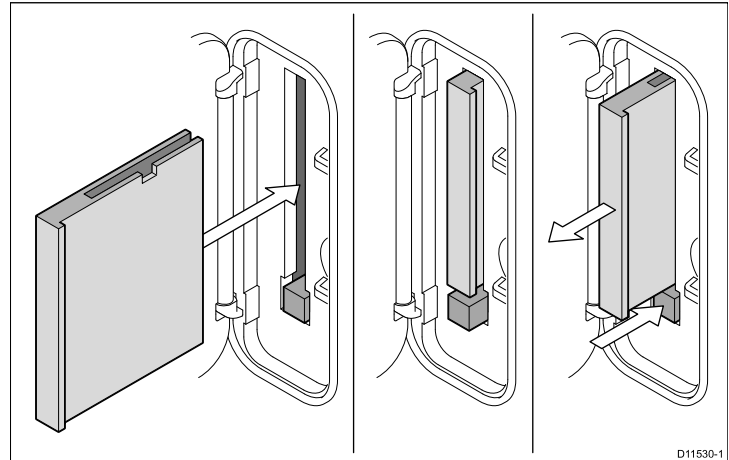

4.3 Ensure chart card door is securely closed

Prevent water ingress.

To prevent water ingress and consequent damage to the display, ensure that the chart card door is firmly closed. This can be confirmed by an audible click.

4.4 Removing a memory card, chart card, or CF / microSD adaptor

1. If the system is powered on, press the **MENU** button. Otherwise, skip to Step 3.
2. Select the **Remove CF Card** menu option.
A message is displayed, confirming that it is safe to remove the card.
3. Open the chart card door.
4. Carefully remove the card. If your system features a physical card eject button this **MUST** be used.
5. To prevent the ingress of water and consequent damage, close the chart card door and press firmly until a click is heard.

4.5 Saving user data and user settings

You can save user data (waypoints, routes, and tracks) or user settings to a memory card for later retrieval.

| Type of data | Description | Notes |
|-----------------------|---|--|
| User data (waypoints) | Saves all waypoints to a single archive file. | Only 1 waypoints archive file can be saved per memory card. |
| User data (routes) | Saves all routes to a single archive file. | Only 1 routes archive file can be saved per memory card. |
| User data (tracks) | Saves all tracks to a single archive file. | Only 1 tracks archive file can be saved per memory card. |
| User settings | Saves the settings you've made in the Setup Menus to a single archive file. | You can save 1 user settings archive file per memory card for each product Series (C-Series, E-Series, or G-Series). However, you can NOT retrieve the settings from a Series to a different Series (for example, G-Series to E-Series). |

Note: Raymarine recommends that you save your user data and user settings to a memory card on a regular basis.

Saving user settings to a memory card

Note: Raymarine strongly recommends that you save settings to a separate memory card, and NOT to a chart card containing cartography.

1. Insert card in to the card slot.
2. Select the **DATA** button.
3. Select the **SAVE AND RETRIEVE SETTINGS** softkey.
4. Select the **SAVE TO CARD** softkey.

Retrieving user settings from a memory card

Note: Raymarine strongly recommends that you save settings to a separate memory card, NOT to a chart card containing cartography.

1. Insert card in to the card slot.
2. Select the **DATA** button.
3. Select the **SAVE AND RETRIEVE SETTINGS** softkey.
4. Select the **RETRIEVE FROM CARD** softkey. This option is only available if a suitable memory card containing a system settings archive file is in the card slot.

Saving data to a memory card

Note: Raymarine strongly recommends that you save data to a separate memory card, and NOT to a chart card containing cartography.

1. Insert card in to the card slot.
2. Select the **DATA** button.
3. Select the **ARCHIVE AND TRANSFER** softkey.
4. Select the **SAVE TO CARD** softkey.
5. Use the **SELECT LIST** softkey to select the type of data that you want to save (Waypoint, Route, or Track).

6. To save all items of that type of data, select the **SAVE ALL...** softkey.
7. To save an individual item of data, select the item from the list and select the **SAVE...** softkey.

Retrieving data from a memory card

1. Insert card in to the card slot.
2. Press the **DATA** button.
3. Select the **ARCHIVE AND TRANSFER** softkey.
4. Select the **RETRIEVE FROM CARD** softkey.
5. Use the **SELECT LIST** softkey to select the type of data that you want to save (Waypoint, Route, or Track).
6. To retrieve all items of that type of data, press the **RETRIEVE ALL...** softkey.
7. To retrieve an individual item of data, select the item from the list and select the **RETRIEVE...** softkey.

Note: If the type of data you have selected already exists in the system memory, use the softkeys to select a suitable action: retrieve as new data, replace existing data, or cancel.

Erasing data from a memory card

1. Insert the card in to the card slot.
2. Press the **DATA** button.
3. Select the **ARCHIVE AND TRANSFER** softkey.
4. Select the **ERASE FROM CARD** softkey.
5. Use the **SELECT LIST** softkey to select the type of data you want to erase.
6. To erase all the data, select the **ERASE ALL...** softkey.
7. To erase an individual item of data from the list, highlight the relevant entry in the list and select the **ERASE...** softkey.

4.6 Transferring data using NMEA

You can transfer waypoints or routes to and from your multifunction display and an external instrument, using NMEA.

Transferring waypoint and route data using NMEA

With NMEA-compatible equipment powered on and connected to your system:

1. Press the **DATA** button.
2. Select the **ARCHIVE AND TRANSFER** softkey.
3. Select the **TRANSFER ON NMEA** softkey.
4. Select the **SEND WPTS ON NMEA**, **SEND RTES ON NMEA**, or **RECEIVE ON NMEA** softkey, as appropriate.

Note: Select the **STOP TRANSFER** softkey at any time to abort the transfer operation.

4.7 Resetting your system

Your system may be reset to its factory default settings if required.

There are 2 types of reset operation, both of which affect the current display you are using, AND any networked displays.

- Settings reset.
- Settings and data reset.

Settings reset

This option resets your setup menus, page sets, and databar settings to factory default. It will NOT affect your waypoints, routes, or tracks data.

Settings and data reset

In addition to the settings reset detailed above, performing a settings and data reset will also remove ALL waypoints, routes, and tracks data.

Performing a settings reset

1. Press the **MENU** button.
2. Select **System Setup**.
3. Select **Settings Reset**.
4. If you have password-protected your waypoints, enter your waypoint password and press the **OK** button.
5. Select the YES option to perform the reset, or select the NO option to abort.

Performing a settings and data reset

Performing a settings and data reset erases ALL waypoints, routes, and track data from your system. BEFORE proceeding with a settings and data reset, ensure that you backup any data that you want to keep on to a memory card.

1. Press the **MENU** button.
2. Select **System Setup**.
3. Select **Settings and Data Reset**.
4. If your waypoints have password protection, enter your waypoint password and press the **OK** button.
5. Select the YES option to perform the reset, or select NO to abort.

Chapter 5: Using waypoints, routes and tracks

Chapter contents

- [5.1 Waypoints on page 50](#)
- [5.2 Routes on page 60](#)
- [5.3 Tracks on page 66](#)
- [5.4 Waypoints, routes and tracks storage capacity on page 68](#)

5.1 Waypoints

A waypoint is a position marked on the screen to indicate a site or a place to navigate to.

As well as acting as position markers, waypoints are also the building blocks used to create routes.

Common waypoint functions are accessed using the waypoints softkey toolbar. This can be shown at any time by pressing the **WPTS MOB** button.

Waypoint display examples

Waypoints on the chart

In the chart applications both active and inactive waypoints are shown. The active waypoint (i.e. the one to which you are heading) has a box placed around the symbol to highlight it.



| Item | Description |
|------|------------------------------|
| 1 | Inactive waypoint |
| 2 | Active waypoint |
| 3 | Alternative waypoint symbols |

By default, all waypoints are indicated on screen by a waypoint symbol (x). You can assign different symbols if required.

Waypoints in the radar application

In the chart and radar applications both active and inactive waypoints are shown. The active waypoint (i.e. the one to which you are heading) has a box placed around the symbol to highlight it.

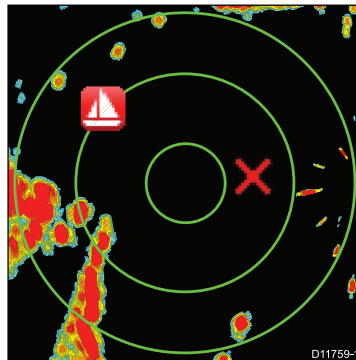

By default, all waypoints are indicated on screen by a waypoint symbol (x). You can assign different symbols if required.

Waypoints in the CDI application

In the CDI application, a waypoint is represented only when it is active.

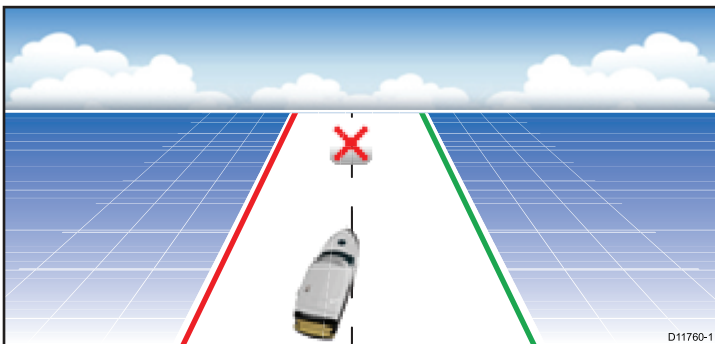

- Erase waypoint.
- Move waypoint.
- Go to waypoint.
- View / edit waypoint.

Waypoint features

There are a range of features for placing, navigating and managing waypoints.

Waypoint features are accessed from:

- **the chart or radar application** — by positioning the cursor over an existing waypoint on the screen.
- **any application** — by pressing the **WPTS MOB** button. This displays the waypoint toolbar
- **the home screen** — by pressing the **WPTS MOB** button or selecting the **My Waypoints** icon. This displays the waypoints list.

The following table lists the waypoint functions you can access at any time, from all applications and the home screen:

| Waypoint function | All applications | Home screen |
|---|------------------|-------------|
| Placing a waypoint | ✓ | ✗ |
| Displaying waypoint information (Waypoint list) | ✓ | ✓ |
| Navigate to a waypoint | ✓ | ✗ |
| Edit waypoint information | ✓ | ✓ |
| Edit waypoint appearance / symbol | ✓ | ✓ |

Waypoints in the fishfinder application

Waypoints in the fishfinder application are represented by a vertical line labelled WPT. This symbol cannot be changed.

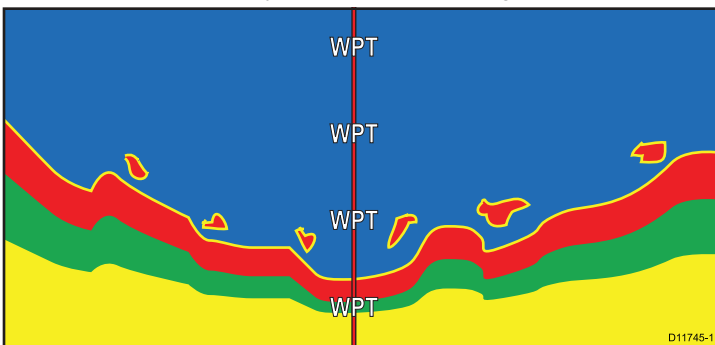

Waypoint hotspots

Placing the cursor over a waypoint in the chart or radar applications displays a pop-up showing the waypoint's basic information.

Selecting a waypoint hotspot also provides the following the softkey functions:

| Waypoint function | All applications | Home screen |
|---|------------------|-------------|
| Move waypoints | ✓ | ✓ |
| Creating and managing waypoint groups | ✓ | ✓ |
| Displaying and managing waypoint groups | ✓ | ✓ |
| Move a waypoint between groups | ✓ | ✓ |

Waypoint placement

Placing a waypoint using touch

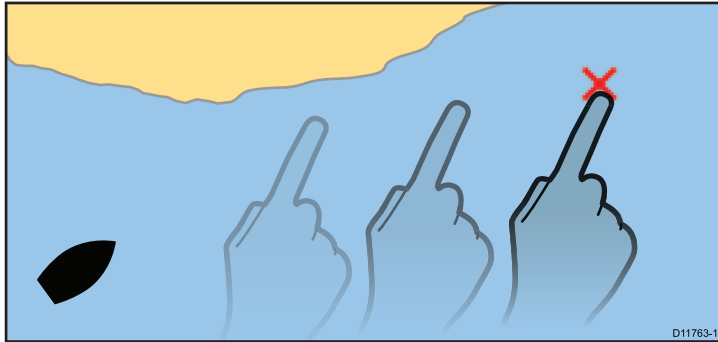

In the chart, radar, fishfinder, or CDI application:

1. Press the **WPTS MOB** button.
2. Touch the area of the screen where you want the waypoint.
3. (Optionally) select the waypoint Name, Group, or Symbol field to customize the waypoint details. Then select **SAVE**.

Placing a waypoint at the cursor position

In the chart, radar, fishfinder, or CDI application:

1. Press the **WPTS MOB** button.
2. Move the cursor to the area of the screen where you want the waypoint to be placed.
3. Select the **WAYPOINT AT CURSOR** softkey.
4. (Optionally) select the waypoint Name, Group, or Symbol field to customize the waypoint details. Then select **SAVE**.

Placing a waypoint at your vessel's position

In addition to positional information, a waypoint placed at the vessel position will capture temperature and sounded depth information (if you have the appropriate sensors connected to your system).

In the chart, radar, fishfinder, or CDI application:

1. Press the **WPTS MOB** button.
2. Select the **WAYPOINT AT VESSEL** softkey.
3. (Optionally) select the waypoint Name, Group, or Symbol field to customize the waypoint details. Then select **SAVE**.

Placing a waypoint at a known position

Note: By default the system will use Lat/Lon coordinates. If required you can use Loran TD coordinates instead. Use the **System Setup Menu** to set the position mode appropriately.

1. Press the **WPTS MOB** button.
2. Select the **WAYPOINT AT LAT/LON** softkey.
3. Select the **EDIT USING KEYPAD** softkey.
4. Enter the Latitude/Longitude position.
5. Select **SAVE**.
6. Close the window.

Waypoint navigation

Navigating to the cursor position on the chart

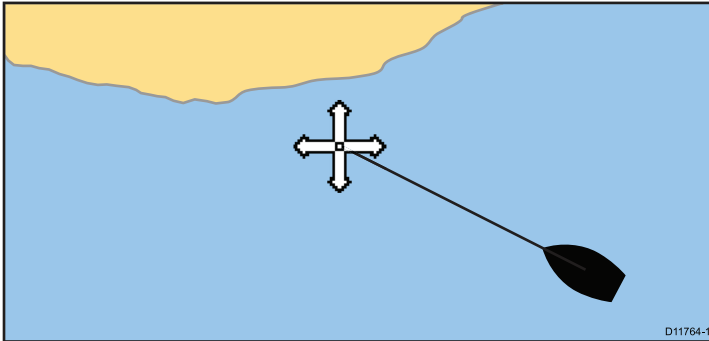

In the chart application:

1. Position the cursor at the desired destination on the chart.
2. Select the **NAVIGATION** softkey.
3. Select the **GOTO CURSOR** softkey.

Navigating to a waypoint on the screen

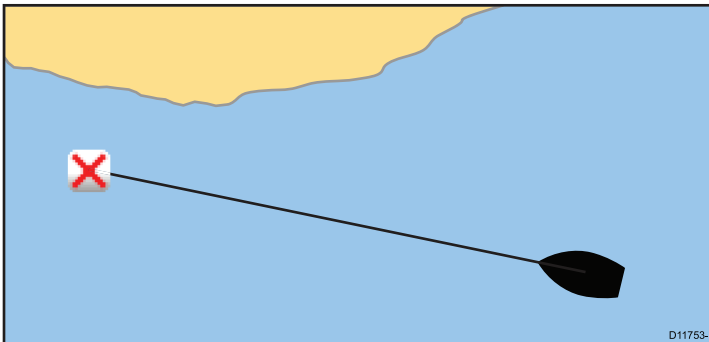

In the chart or radar application:

Using waypoints, routes and tracks

1. Place the cursor over the waypoint.
The softkeys change to show the waypoint options.
2. Select the **GOTO WAYPOINT** softkey.
The required course heading to the waypoint is shown on the screen.

Note: You can select the **STOP GOTO** softkey at any time to cancel the action.

Navigating to a waypoint in the Waypoints List

1. Press the **WPTS/MOB** button, or select the **Navigation** softkey in the chart window.
2. Select the **GOTO WAYPOINT OPTIONS** softkey.
3. Select the required waypoint from the list.
4. Select the **GOTO WAYPOINT** softkey.

Cancelling navigation to a waypoint

1. Press the **WPTS/MOB** button.
2. Select the **GOTO WAYPOINT OPTIONS** softkey.
3. Select the **STOP GOTO** softkey.
4. Alternatively, in the chart application, position the cursor over the active waypoint, and select the **STOP GOTO** softkey.

Note: Once navigation is no longer active, the waypoint symbol returns to its normal unboxed state, and the dashed line between your vessel and the waypoint is removed.

Waypoint information

When you create a waypoint, the system assigns a number of pieces of information regarding the location marked. You can view and edit the details of any waypoint that has been created and stored.

The following information is assigned or captured for each waypoint:

- Name
- Position (as Lat/Lon and range/bearing from vessel)
- Temperature (requires appropriate sensor, only for waypoints captured at the vessel position)
- Depth (requires appropriate sensor, only for waypoints captured at the vessel position)
- Date and time
- Comment — You can add your own text comments to a waypoint.
- Symbol — A default symbol is assigned, or you can select an alternative.

There are 2 features which allow you to view or edit waypoint information:

- Place the cursor over a waypoint hotspot on the 2D chart or Radar screen to view selected information.
- Use the waypoint list for comprehensive information to view and edit as required.

Displaying the waypoint list

1. Press the **WPTS/MOB** button.
2. Press the **REVIEW AND EDIT WAYPOINTS** softkey.

Waypoint editing

Editing waypoint details

With the Waypoint List displayed:

1. Select the **VIEW AND EDIT DETAILS** softkey.
The Edit Waypoint dialog is displayed.
2. Select the field you want to change.
3. Select the **EDIT...** softkey to display the on-screen keyboard.
4. Use the on-screen keyboard to make the changes, then select the on-screen keyboard's **SAVE** key.



















Editing a waypoint on the chart or radar screen

































In the chart or radar application:













1. Place the cursor over the waypoint.
The softkeys change to show the waypoint options.
2. Select the **VIEW AND EDIT DETAILS** softkey.
The Edit Waypoint dialog is displayed.
3. Select the field you want to edit.
4. Use the **EDIT...** softkey to display the on-screen keyboard.
5. Use the on-screen keyboard to make the changes, and then select the on-screen keyboard's **SAVE** key.

Waypoint symbols

There are a range of symbols to represent different waypoint types.

| Symbol | Type | Symbol | Type |
|---|--------------------------|---|---------------|
|  | Airport |  | Anchor |
|  | Billfish |  | Bottom mark |
|  | Bridge |  | Buoy |
|  | Cans |  | Car |
|  | Caution |  | Circle |
|  | Concrete |  | Diamond |
|  | Diamond quarter |  | Diver down |
|  | Diver down (alternative) |  | Dolphin |
|  | Dot |  | Dotted square |

| Symbol | Type | Symbol | Type |
|--|---------------|---|---------------------|
|  | End marker |  | Fad |
|  | Fish |  | Fish (1–star) |
|  | Fish (2–star) |  | Fish (3–star) |
|  | Fish trap |  | Hill peak |
|  | Ledge |  | Lobster |
|  | Lost target |  | Man overboard (MOB) |
|  | Marker |  | Martini |
|  | NMEA |  | Nuns |
|  | Oil rig |  | Oyster |
|  | Post |  | Preferred marks |
|  | Private reef |  | Public reef |
|  | Reef |  | Reef ball |
|  | Restriction |  | Rocks |
|  | Sail boat |  | School of fish |
|  | SeaTalk |  | Seaweed |
|  | Shark |  | Skull |

| Symbol | Type | Symbol | Type |
|---|------------|---|--------------|
|  | Small fish |  | Sport fisher |
|  | Square |  | Start marker |
|  | Swimming |  | Tank |
|  | Top mark |  | Tower |
|  | Trawler |  | Tree |
|  | Triangle |  | Wreck |

Changing a waypoint symbol

With the Waypoint List displayed:

1. Select the **VIEW AND EDIT DETAILS** softkey.
The Edit Waypoint dialog is displayed.
2. Select the Symbol field.
3. Select the required symbol in the list.

Showing and hiding waypoint names

In the chart, radar, fishfinder, or CDI application:

1. Press the **WPTS/MOB** button.
2. Select the **REVIEW AND EDIT WAYPOINTS** softkey.
3. Select the **SHOW/HIDE WAYPOINTS** softkey.
4. Using the **WAYPOINT NAME** softkey, select the **WAYPOINT NAME ON** option to show waypoint names, or the **WAYPOINT NAME OFF** option to hide waypoint names.

Note: Waypoints in an active route are always displayed, regardless of whether the display is set to show or hide.

Showing and hiding waypoint groups / symbols

In the chart, radar, fishfinder, or CDI application:

1. Press the **WPTS/MOB** button.
2. Select the **REVIEW AND EDIT WAYPOINTS** softkey.
3. Select the **SHOW/HIDE WAYPOINTS** softkey.
4. Using the **SHOW BY** softkey, select the **SHOW BY GROUP** or **SHOW BY SYM** option, as appropriate.
A list of available waypoint groups or symbols is displayed.
5. Select the waypoint group or symbol that you want to show or hide.
6. Using the **ON CHART** softkey, select the **SHOW** or **HIDE** option, as appropriate.
7. Repeat Steps 5 to 6 for each waypoint group or symbol you want to show or hide.

Moving waypoints

Moving a waypoint on the chart or radar screen

In the chart or radar application:

1. Move the cursor to the relevant waypoint.
The softkeys change to provide waypoint options.
2. Select the **MOVE WAYPOINT** softkey.
3. Select the new position for the waypoint.
4. Select the **PLACE WAYPOINT** softkey.

Moving a waypoint within a route

In the chart application:

1. Move the cursor over the waypoint you want to move.
The softkeys change to provide waypoint options.
2. Select the **MOVE WAYPOINT** softkey.
3. Move the cursor so that it stretches the leg of the route to the desired position on the chart.
4. Select the **PLACE WAYPOINT** softkey.

Moving a waypoint by entering new coordinates

With the Waypoint List displayed:

1. Select the **VIEW AND EDIT DETAILS** softkey.
The Edit Waypoint dialog is displayed.
2. Select the Position, Bearing, or RNG field, as appropriate.
3. Use the rotary control to enter the new coordinates, or select the **EDIT USING KEYPAD** softkey and use the on-screen keyboard.

Erasing waypoints

Erasing a waypoint on screen

In the chart or radar application:

1. Move the cursor to the relevant waypoint.
The softkey toolbar changes to show the waypoint options.
2. Select the **ERASE WAYPOINT** softkey.
3. Select the **YES** softkey to confirm, or **NO** softkey to cancel.

Erasing a waypoint using the waypoint list

With the Waypoint List displayed:

1. Highlight the waypoint you want to erase.
2. Select the **ERASE WAYPOINT** softkey.
3. Select the **YES** softkey to confirm.

Note: If a route is hidden, its waypoints can still be displayed. If you attempt to erase a waypoint from a hidden route, a warning is displayed, and the waypoint cannot be erased.

Erasing all waypoints

1. Press the **DATA** button.
2. Select the **ARCHIVE AND TRANSFER** softkey.
3. Select the **ERASE FROM SYSTEM** softkey.
4. Use the **SELECT LIST** softkey to select the **WPT** option.
5. Select the **ERASE ALL WAYPOINTS** softkey.

6. Select the **YES** softkey to confirm, or the **NO** softkey to cancel.

Note: If a route is hidden, its waypoints can still be displayed. If you attempt to erase a waypoint from a hidden route, a warning is displayed, and the waypoint cannot be erased.

Waypoint groups

In order to make your waypoints easier to manage, you can organize them into groups of your choice. When fishing, for example, you may only wish to see the waypoints that indicate good fishing sites.

Provided that you have not changed the default group, all waypoints are automatically placed in the default “My Waypoints” group when they are created.

Note: A waypoint can only belong to one group.

Displaying the waypoint group list

1. Press the **WPTS MOB** button. or select **My Waypoints** from the home screen.
2. Select the **MANAGE SYMBOLS AND GROUPS** softkey.

The Waypoint Group List is displayed.

You can now:

- Make a new waypoint group.
- Move waypoints between groups.
- Rename groups.
- Erase groups.

Making a new waypoint group

With the Waypoint Group List displayed:

1. Select the **MAKE NEW GROUP** softkey.
2. Select the name field.
The on-screen keyboard is displayed.
3. Edit the name.

4. Select the on-screen keyboard’s **SAVE** key.

Moving waypoints between groups

With the Waypoint Group List displayed:

1. Select the appropriate waypoint group from the list.
2. Select the **MOVE BETWEEN GROUPS** softkey.
3. Select the **SELECT GROUP A** softkey.
4. Using the rotary control, select the waypoint group that contains the waypoint you want to move.
5. Press the **OK** button.
6. Highlight the Group B column.
7. If the Group B column does not contain the waypoint group you want to move your waypoint to, select the **SELECT GROUP B** softkey, and use the rotary control to select the required group.
8. In the Group A column, select the waypoint you want to move.
9. Select the **MOVE WAYPOINT FROM A TO B** softkey.

The waypoint is moved to the new group.

Renaming a waypoint group

With the Waypoint Group List displayed:

1. Select the group you want to rename.
2. Select the **RENAME GROUP** softkey.
3. Select the **EDIT GROUP NAME** softkey.
The on-screen keyboard is displayed.
4. Using the on-screen keyboard, edit the group name.
5. Select the on-screen keyboard’s **SAVE** key.

Changing the default waypoint group

With the Waypoint Group List displayed:

1. Select the **SET DEFAULT SYM & GROUP** softkey.
2. Select the **EDIT DEFAULT** softkey.
3. Select the waypoint group that you want to make the default.
4. Press the **OK** button.

Erasing a waypoint group

When you delete a waypoint group, the group name and all the associated waypoints are erased from the system. If a group contains one or more waypoints that you want to keep, move these waypoints out of the group before deleting the waypoint group. You can erase any waypoint group except the following:

- the 'My Waypoints' group,
- a group containing an active waypoint,
- a group that contains waypoints that are part of a stored route.

With the Waypoint Group List displayed:

1. Select the waypoint group that you want to erase.
2. Select the **ERASE GROUP** softkey.
3. Select **YES** to confirm the action, or **NO** to cancel.

Managing waypoints

Your system features a number of functions to help you manage your waypoints effectively.

You can:

- Archive waypoints to a memory card, for backup purposes.
- Transfer your waypoints to other NMEA compatible equipment.
- Add password protection to your waypoints to prevent unauthorized access.

Archiving waypoints to a memory card

You can archive your waypoints to a memory card for backup purposes.

You can choose to save all of your waypoints, or just a specific waypoint group.

Note: DO NOT save data (waypoints, routes, and so on) to a chart card, as the charts may be overwritten.

1. Insert a memory card in the card slot.

2. Press the **DATA** button.
3. Select the **ARCHIVE AND TRANSFER** softkey.
4. Select the **SAVE TO CARD** softkey.
5. Select the WPT option using the **SELECT LIST** softkey.
6. To save all waypoints, select the **SAVE ALL** softkey.
7. To save a specific waypoint group and its waypoints, highlight the group in the list and then select the **SAVE GROUP** softkey.

Waypoint transfer (NMEA)

You can send and receive waypoints to and from other NMEA compatible devices.

Note: If the system receives an active waypoint over SeaTalk or NMEA, it is displayed but cannot be edited. Waypoints received over SeaTalk are distinguished by an "S" waypoint icon. Waypoints received over NMEA are distinguished by an "N" waypoint icon.

Sending waypoints on NMEA

1. Press the **DATA** button.
2. Select the **ARCHIVE AND TRANSFER** softkey.
3. Select the **TRANSFER ON NMEA** softkey.
4. Select the appropriate port number, using the **NMEA PORT** softkey.
5. Set your third-party NMEA compatible device to receive mode.
6. Select the **SEND WPTS ON NMEA** softkey on your multifunction display.

Receiving waypoints on NMEA

1. Press the **DATA** button.
2. Select the **ARCHIVE AND TRANSFER** softkey.
3. Select the **TRANSFER ON NMEA** softkey.
4. Select the appropriate port number using the **NMEA PORT** softkey.

5. Set your third-party NMEA compatible device to transmit mode.
6. Select the **RECEIVE ON NMEA** softkey on your multifunction display.

Password protecting your waypoints

You can prevent access to, modification, and visibility of your waypoints and routes by applying a password.

Password Confirmation

When Password Protection is enabled and you are attempting to access a password protected function for the first time during a power-cycle, the system will request confirmation of your password before you can:

- Access WPTS key functions. This does not affect the operation of the MOB function.
- Access ROUTE softkey functions.
- Create a route from a track. All other track functions are unaffected.
- Archive or transfer any waypoints.
- Enter the Waypoint Password Setup menu.

Note: Once you have provided a password to the system, it must be entered to access the Password Setup sub-menu, regardless of the whether Password Protection is set to ON or OFF.

Note: Raymarine strongly recommends that you backup your waypoint data BEFORE password protecting your waypoints. This is so that, in the event that you forget your password, you can easily restore your waypoints.

Disabled Data/Functions

When Password Protection is ON and you have not entered a password, you will NOT be able to:

- View details of waypoint and route databases.

- Edit waypoints or routes.
- Goto an existing waypoint.
- Follow a route.
- View waypoints on screen (even when the SHOW/HIDE status is set to SHOW).
- View waypoint names on screen (even when WAYPOINT NAME is set to ON).

All other options including GOTO CURSOR are unaffected.

Specifying a password for waypoints

1. Press the **MENU** button.
2. Select the System Setup menu item.
3. Select the Waypoint Password Setup menu item.
4. Select the ON option for the Enable Password menu item.
5. Press the **OK** button.
6. Read the displayed warning, and press the **YES** softkey to accept it, as appropriate.
7. Enter the password (1 to 16 characters, and case sensitive).
8. Press the **OK** button.
9. Repeat Steps 7 to 8 to confirm the password.
10. Add a hint to help you remember the password (optional).
11. Press the **OK** button.

The password is now set and protection enabled, although access to the waypoint and route functions remains available until you restart your multifunction display.

Changing the waypoints password

1. Press the **MENU** button.
2. Select the System Setup menu item.
3. Select the Waypoint Password Setup menu item.
4. Select the Change Password menu item.

5. Enter your new waypoints password (1 to 16 characters, and case sensitive).
6. Press the **OK** button.
7. Repeat Steps 5 to 6 to confirm the password.
8. Enter a hint to help you remember the password (optional).
9. Press the **OK** button.

Disabling password protection for waypoints

1. Press the **MENU** button.
2. Select the System Setup menu item.
3. Select the Waypoint Password Setup menu item.
4. When prompted, enter your existing waypoints password.
5. Press the **OK** button.
6. Select the OFF option for the Enable Password menu item
7. Press the **OK** button.

5.2 Routes

A route is a series of waypoints typically used to assist with passage planning and navigation.

A route is displayed on screen as a series of waypoints linked by a line.

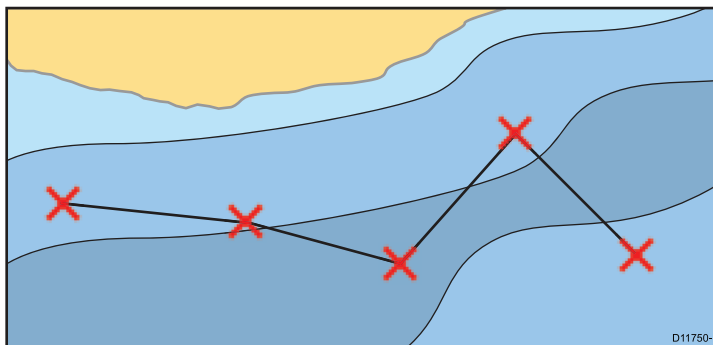

Route features

There are a range of route features for building, navigating and managing routes.

Route features are accessed from:

- **the chart application** — by positioning the cursor over an existing route on the chart.
- **the chart application** — by using the **Navigation Options** softkey.
- **the home screen** — by selecting **My Routes**. This displays the Routes list.

The route features allow you to:

- Build a temporary route for immediate use (Quick Route).

- Build and save a route for use when required (stored in the route list).
- Navigate (follow) routes.
- Manage and edit routes stored on the system.

You can also build a route from an existing track. Select the **My Tracks** icon to access track functions on the home screen.

Route building

A route can consist of a combination of:

- New waypoints which you place on the screen as required and/or
- existing waypoints selected from a list displayed on screen.

Note: A route can also be created from a track.

As each waypoint is added, it is assigned an index number corresponding to its position in the route and drawn on the chart using the currently specified symbol. The following should be noted:

- When a route is being built it is not active and does not affect any current navigation.
- You cannot save a new route if any of the waypoints within it are currently active.

Building a route using touch

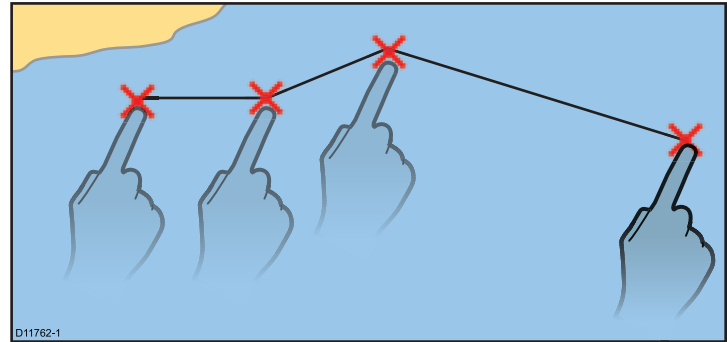

In the chart application:

1. Select the **PLANNING** softkey.
2. Select the **BUILD NEW ROUTE** softkey.
3. Touch the area of the screen where you want the first waypoint.
4. Touch the screen to place subsequent waypoints in order.
5. When you have finished you can follow the route immediately or save for future use:
 - To follow the route immediately without saving it for future use, select the **FOLLOW (QUICK) ROUTE** softkey.
 - To save the route for future use, press the **SAVE ROUTE** softkey.

Building a route on the chart

In the chart application:

1. Select the **PLANNING** softkey.
2. Select the **BUILD NEW ROUTE** softkey.
3. Select the desired position on the chart for either a new or an existing waypoint as required.
4. Select the appropriate option on the softkey toolbar:

- To use an existing waypoint select the **USE THIS WAYPOINT** softkey.
 - For a new waypoint select the **PLACE WAYPOINT** softkey.
5. Repeat Steps 3 to 4 for each subsequent waypoint, until the route is complete.
 6. To follow the route immediately without saving it for future use (Quick Route), select the **FOLLOW (QUICK) ROUTE** softkey.
 7. To save the route for future use, press the **SAVE ROUTE** softkey.

Note: If you place a waypoint at the wrong position, press the **UNDO WAYPOINT** softkey.

Building a route using the waypoint list

In the chart application:

1. Select the **PLANNING** softkey.
2. Select the **BUILD NEW ROUTE** softkey.
3. Select the **USE WAYPOINT LIST** softkey.
4. Highlight the waypoint you want to use from the waypoint list.
5. Select the **INSERT WAYPOINT** softkey.
6. Repeat Steps 4 to 5 for each existing waypoint you want to add to the route, until the route is complete.
7. To follow the route immediately without saving it for future use (Quick Route), select the **FOLLOW (QUICK) ROUTE** softkey.
8. To save the route for future use, select the **SAVE ROUTE** softkey.

Build a route from a track

You can create a route from a recorded track.

When a track is converted the system creates the closest route through the recorded track, using the minimum number of waypoints. Each waypoint created will be saved with the depth and temperature data (if applicable) for that position.

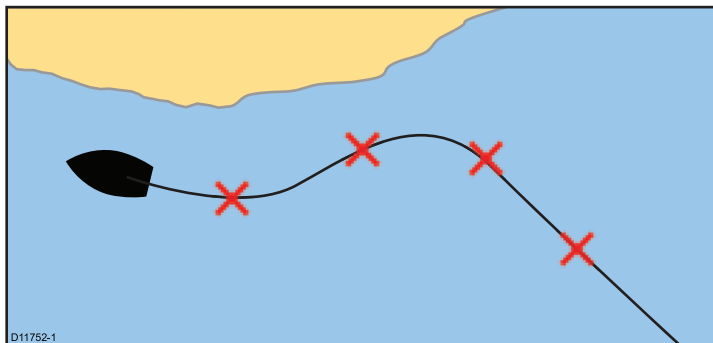

Note: If a track break occurs, only the last segment is converted to a route.

Building a route from a track

In the chart application:

1. Select the **PLANNING** softkey.
2. Select the **MY TRACKS** softkey.
The Track List is displayed.
3. Select the **CREATE ROUTE FROM TRACK** softkey.
4. Highlight the required track in the list.
5. Select the **CREATE ROUTE FROM TRACK** softkey.
6. Select the **YES** softkey to name the route, or **NO** to accept the default route name.

On completion, the maximum deviation of the route from the recorded track is displayed and the new route is added to the route list. It can now be displayed, edited and erased etc. in the same way as other routes in the system.

Building a route from a track displayed on the chart

In the chart application:

1. Position the cursor over the required track.

2. Select the **CREATE ROUTE FROM TRACK** softkey.
3. Select the **YES** softkey to name the route, or **NO** to accept the default route name.

A route will be created and the current track will continue to be recorded until you select the **STOP TRACK** softkey.

Navigating a route

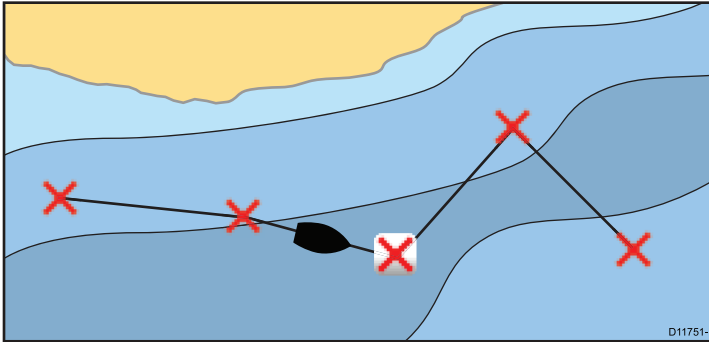

You can follow any route stored on the display. When following a route you visit each waypoint in order. You may also use the follow route options in conjunction with a compatible autopilot to automatically navigate along your chosen route.

There are a number of ways to select the follow route option:

- Using a temporary “Quick Route”.
- From a selected waypoint or any leg within a route.
- Using a stored route within the route list.

You can also follow any route in reverse order.

Following a quick route

In the chart application:

1. Build your route.

2. After adding the final waypoint in your route, press the **FOLLOW (QUICK) ROUTE** softkey.

Note: You can stop following a route at any time by pressing the **STOP FOLLOW** softkey.

If you do not rename a quick route, it will be overwritten and its waypoints deleted when a new quick route is built.

Following a stored route

In the chart application:

1. Select the **NAVIGATION** softkey.
2. Select the **FOLLOW ROUTE OPTIONS** softkey.
The Route List is displayed.
3. Select the route you want to follow.
4. Select the **FOLLOW ROUTE** softkey.

Note: You can stop following a route at any time by selecting the **STOP FOLLOW** softkey.

Cancelling navigation of a route

From the chart navigation options:

1. Select the **STOP FOLLOW** softkey.

Arriving at a waypoint

As your boat approaches a waypoint, the waypoint arrival alarm provides a warning.

1. Press the **ACKNOWLEDGE** softkey.

Once the alarm is acknowledged, the next waypoint is selected, and the display updates to indicate the next leg of the route.

Note: You can set the approach distance (radius) at which the waypoint arrival alarm will sound using the alarm setup menu.

Advancing to the next waypoint in a route

You can skip the current active waypoint and advance to the next waypoint in a route at any time.

While following a route in the chart application:

1. Press the **GOTO** softkey, or position the cursor over the route.
2. Press the **ADVANCE WAYPOINT** softkey.

Note: If the current destination is the last waypoint, the chart advances on to the first waypoint in the route.

Following a route in reverse order

In the chart application:

1. Select the **NAVIGATION** softkey.
2. Select the **FOLLOW ROUTE OPTIONS** softkey.
The Route List is displayed.
3. Select the route you want to follow.
4. Select the **REVERSE AND FOLLOW** softkey.

Note: You can stop following a route at any time by selecting the **STOP FOLLOW** softkey.

Cross Track Error (XTE)

Cross Track Error (XTE) is the amount of deviation from your intended route or waypoint, expressed as a distance.

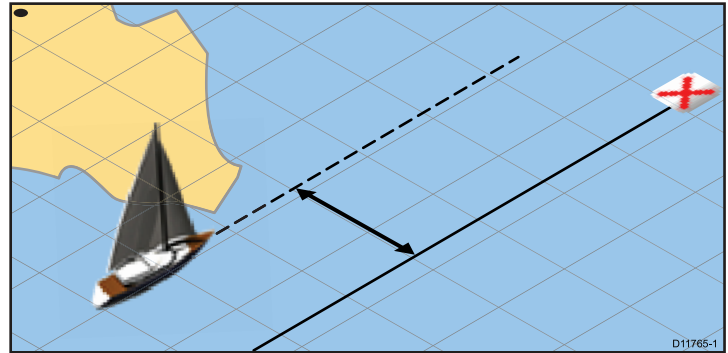

In the event that you steer off-track, you can go straight to your target by resetting XTE.

Resetting Cross Track Error (XTE)

While following a route in the chart application:

1. Press the **RESTART XTE** softkey.

Resetting XTE results in a new course from the current vessel position to the current target waypoint. This does not affect your saved route.

Erasing a route

In the chart application:

1. Select the **PLANNING** softkey.
2. Select the **MY ROUTES** softkey.
3. Highlight the required route from the list.
4. Select the **ERASE ROUTE** softkey.
5. Select **YES** to confirm the action, or **NO** to cancel.

Note: You can delete any route, except for the one that you are currently following. When you erase a route, only those waypoints associated with that route are deleted.

Review or edit a route

There are a variety of attributes associated with routes. These can be reviewed and edited.

You can:

- Show or hide a route on the chart screen.
- Review details of the route
- Add and remove waypoints.
- Move waypoints within a route.
- Reverse a route.
- Change the name or color of a route.
- Erase a route.
- Show or hide a route on the chart screen.
- Adjust the line thickness for routes.

Note: An active route can be edited, with the exception of the target waypoint. If a waypoint being edited becomes the target, then the system shall cancel the edit; the waypoint shall remain in its original position.

Selecting a route to review or edit

1. Do one of the following to select the required route:
 - With the chart application active, select a route on screen, then press the **Review & Edit This Route** softkey.
 - With the chart application active, use the following softkey sequence; **Navigation options > Planning > My Routes** and select the required route from the list.
 - From the home screen, select **My routes** and select the required route from the list.

Adding a waypoint to a stored route

In the chart application:

1. Select the **PLANNING** softkey.
2. Select the **MY ROUTES** softkey.
3. Select the route you want to add a waypoint to.
4. Select the **AMEND ROUTE COURSE** softkey.
5. Select the **USE WAYPOINT LIST** softkey.
6. Highlight the right-hand column of the list.
7. Use the trackpad to select the appropriate place for the waypoint.
8. Press the trackpad left to highlight the left-hand column of the list.
9. Highlight the waypoint you want to insert at the start of the route.
10. Select the **INSERT WAYPOINT** softkey.
11. Press the **OK** button.

Adding a waypoint to a route on the chart screen

In the chart application:

1. Move the cursor over the appropriate leg of the route.
The softkeys change to provide route functions.
2. Select the **INSERT WAYPOINT** softkey.
3. Move the cursor so that it stretches the leg of the route to the desired position on the chart.
4. Select the **PLACE WAYPOINT** softkey.

Removing a waypoint from a route

In the chart application:

1. Using the trackpad, move the cursor over the waypoint you want to remove.
2. Press the **REMOVE WAYPOINT** softkey.

Moving a waypoint within a route

In the chart application:

1. Move the cursor over the waypoint you want to move.
The softkeys change to provide waypoint options.
2. Select the **MOVE WAYPOINT** softkey.

3. Move the cursor so that it stretches the leg of the route to the desired position on the chart.
4. Select the **PLACE WAYPOINT** softkey.

Reversing a route

In the chart application:

1. Ensure that you are not following a route (press the **STOP FOLLOW** softkey to stop following a route).
2. Position the cursor over the appropriate route.
3. Press the **REVERSE ROUTE** softkey.

The waypoints in the route are renumbered, and the route name is moved.

Showing or hiding a route

In the chart application:

1. Using the trackpad, position the cursor over the appropriate route.
2. Press the **HIDE ROUTE** softkey.

Adjusting the thickness of route lines

In the chart application:

1. Press the **MENU** button.
2. Using the trackpad, select the Chart Setup option.
3. Using the trackpad, select the Route Width menu item.
4. Using the trackpad, select the appropriate route line thickness.
5. Press the **OK** button.

5.3 Tracks

A track is an on-screen trail that shows the route you have taken. This trail is made up of a series of track points which are created automatically. You can save the track to create a permanent record of where you have been



With tracks you can:

- Review where you have been.
- Create a route from a track.

Creating a track

In the chart application:

1. Select the **NAVIGATION** softkey.
2. Select the **START TRACK** softkey.

As you navigate your vessel, your journey is automatically recorded as a track.

Note: If the power fails whilst a track is being recorded or the position fix is lost, a break will occur in the track. Only the last segment of a track can be converted into a route.

Note: If the maximum number of tracking points is reached, you will be warned. The track will continue to be recorded with the earlier tracking points being overwritten.

Erasing a track

In the chart application:

1. Select the **PLANNING** softkey.
2. Select the **MY TRACKS** softkey.
3. Highlight the required track from the list.
4. Select the **ERASE TRACK** softkey.
5. Select the **YES** softkey to confirm the action, or **NO** to cancel.

Note: You can also erase all tracks at once, using the **DATA > ARCHIVE AND TRANSFER** function.

Reviewing and editing a track

You can review and edit aspects of the tracks stored.

You can:

- Erase a track.
- Create a route from a track.
- Show or hide a track on the chart (only available from the chart application).
- Change the name of a track.
- Change the color of a track.
- Erase a track.

Selecting a track to review or edit

1. Do one of the following to select the required track:
 - With the chart application active, select a track on screen.

- With the chart application active, use the following softkey sequence, **Navigation options > Planning > My Tracks**.
- From the home screen, select **My tracks**.

You can then proceed and review or edit the required track using the options available.

Track interval

The track interval specifies the time period or distance between the points in a track.

You can adjust the interval between points which can help ensure best use of the available storage.

The settings are available from the **Chart Setup Menu**:

- **Record Vessel Track By** — specifies the interval type (Auto / Time / Distance).
- **Track Interval** — specifies the interval value (for example, 15 minutes).

For example when creating a track for a long journey, an interval set to Auto could result in rapid use of all of the storage available for track points. In this case selecting a higher value for the Track Interval would provide capacity for a longer track.

Setting the track interval

In the chart application:

1. Press the **MENU** button.
2. Select **Chart Setup**.
3. Select the **Record Vessel Track By** option and set to the appropriate value:
 - Auto— The track interval is automatically set.
 - Time— The track points are placed at regular intervals of time.
 - Distance— The track points are placed at regular intervals of distance.
4. Select the **Track interval** and set to the appropriate value:

- Units of time from the list displayed (available if “record track interval by” is set to time).
- Units of distance from the list displayed (available if “record track interval by” is set to distance).
- Greyed out; no options are available if the “record track interval by” is set to auto).

5.4 Waypoints, routes and tracks storage capacity

The display can store the following quantities of waypoints, routes and tracks

| | |
|-----------|---|
| Waypoints | <ul style="list-style-type: none"> • 3000 Waypoints • 100 waypoint groups |
| Routes | <ul style="list-style-type: none"> • 150 routes, each consisting of up to 50 waypoints. |
| Tracks | <ul style="list-style-type: none"> • 15 tracks, each consisting of up to 10000 track points. |

Chapter 6: Using the chart

Chapter contents

- [6.1 Chart application overview on page 70](#)
- [6.2 Vessel position and orientation on page 72](#)
- [6.3 Chart views on page 75](#)
- [6.4 Chart planning options on page 79](#)
- [6.5 Chart navigation options on page 79](#)
- [6.6 Measuring distances and bearings on page 80](#)
- [6.7 Chart vectors on page 81](#)
- [6.8 Current information on page 82](#)
- [6.9 Tide information on page 83](#)
- [6.10 Chart object information on page 85](#)
- [6.11 Chart layers on page 86](#)
- [6.12 Chart presentation on page 90](#)
- [6.13 Chart setup on page 93](#)

6.1 Chart application overview

The chart application provides an electronic chart with passage planning and navigation features. It combines 2D and 3D viewpoints and provides a variety of cartographic information regarding your surroundings and charted objects.

Typical uses for the chart application include :

- Monitor your vessel location and heading.
- Interpret your surroundings.
- Measure distance and bearing.
- Navigate using waypoints.
- Plan, and Navigate using routes.
- Monitor fixed and moving objects using radar overlay.
- Monitor vessels in your vicinity using AIS data.
- Keep track and record your course.
- View information for charted objects.
- Overlay NOWRad weather information.
- Overlay aerial photos and other chart enhancements

Note: To obtain full 3D detail, you must have chart cards containing 3D cartography for the appropriate geographic area.

You can also use your multifunction display to customize your chart application to your own particular requirements and circumstances. You can:

- Alter the way the chart is drawn in relation to your vessel and the direction you are travelling in (chart orientation and motion mode).
- Manage and edit chart data you have entered.
- Control the level of detail displayed on-screen.

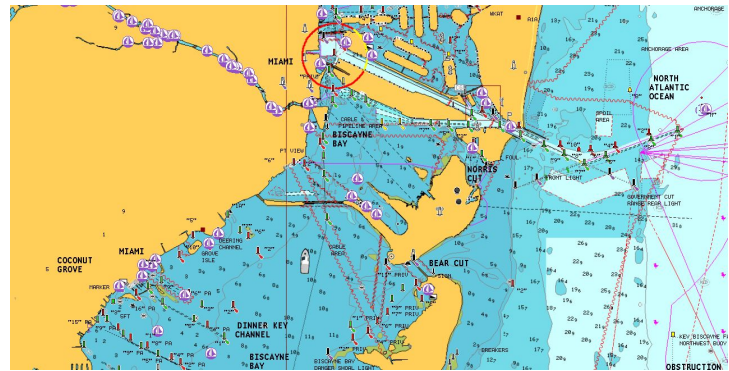

Multiple applications

With most applications, it is possible to run 4 instances of the same application at any one time. However there are 2 exceptions to this, which are:

- **Chart application** — maximum 2 simultaneous instances per multifunction display.
- **Sirius satellite radio application** — maximum 1 instance per multifunction display, at any one time.
- **Video application** — maximum 1 instance per multifunction display, at any one time.

Chart datum

The chart datum setting affects the accuracy of the vessel position information displayed in the chart application.

In order for your GPS receiver and multifunction display to correlate accurately with your paper charts, they must be using the same datum.

The default datum for your multifunction display is WGS1984. If this is not the datum used by your paper charts, you can change the datum for your multifunction display, using the **MENU > Chart Setup > Datum** menu item.

When you change the datum for your multifunction display, the chart grid will subsequently move according to the new datum, and the latitude/longitude of the cartographic features will also change accordingly. Your multifunction display will attempt to set up any GPS receiver to the new datum, as follows:

- If you have a Raymarine GPS receiver using SeaTalk or SeaTalk^{ng}, it will automatically correlate each time you change the datum on the multifunction display.
- If you have a Raymarine GPS receiver using NMEA0183, or a third-party GPS receiver, you must correlate it separately.

It may be possible to use your multifunction display to correlate an NMEA0183 GPS receiver. Go to **MENU > GPS Status**. If the datum version is displayed, it may be possible to change it by selecting the **OTHER SETUP** softkey and choosing the appropriate datum. If the NMEA0183 GPS receiver does NOT state which datum it is using, you must select the NMEA0183 GPS datum using the **MENU > GPS Status > Other Setup > NMEA0183 GPS Datum** menu item.

Note: Raymarine recommends that you check the displayed vessel position in the chart application against your actual proximity to a known charted object. A typical GPS has an accuracy of between 5 and 15 m.

Chart cards overview

Chart cards provide additional cartographic information.

Obtain detailed cartographic information for the area that you navigate using Navionics® chart cards. To check the current availability of Navionics chart card types, please visit www.navionics.com or www.navionics.it. The amount of cartographic detail shown varies for different areas and for different

scales. The chart scale in use is indicated in the status bar — the number represents the distance in nautical miles horizontally across the chart.

You can remove and insert chart cards while a chart is displayed provided that you follow the correct procedure. The chart information is retained on-screen until the chart application redraws the screen; for example, when you pan outside the current area, or use the **Range** button to change the chart scale.

Caution: Care of chart cards

To avoid irreparable damage to and/or loss of data from chart cards:

- Ensure that chart cards are fitted the correct way around. DO NOT try to force a card into position.
- DO NOT save data (waypoints, routes, and so on) to a chart card, as the charts may be overwritten.
- DO NOT use a metallic instrument such as a screwdriver or pliers to remove a chart card.
- Safe removal. Use the Remove Card menu option before removing the chart card.

Chart compatibility

Your multifunction display is supplied with embedded Navionics electronic charts. You can also insert Navionics chart cards to get enhanced chart detail and additional chart features.

Your multifunction display is compatible with the following Navionics chart cards:

- Silver
- Gold
- Gold+

- Platinum
- Platinum+
- Fish'N Chip
- Hotmaps

Note: Refer to the Raymarine website (www.raymarine.com) for the latest list of supported chart cards.

6.2 Vessel position and orientation

Vessel position on the chart display

Your current position is represented on screen by a boat symbol.

The boat symbol is shown below:

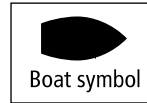

Note: The boat symbol can be customized, so may appear differently on your display.

If neither heading nor Course Over Ground (COG) data is available, the vessel is shown as a solid circle. If positional data has been selected for display, your position will be displayed in the data bar under VES POS.

Chart orientation

The orientation of a chart refers to the relationship between the chart and the direction that you are travelling in.

It is used in conjunction with motion mode to control how your vessel and chart relate to one another and how they are displayed on screen.

The mode you choose applies to all chart instances, and is restored at power up.

The following options are available:

North Up (N-up)

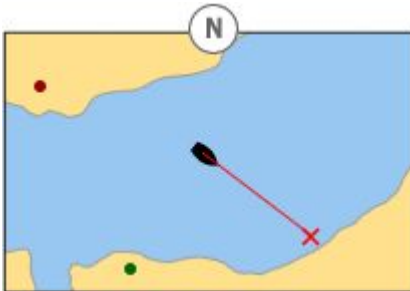

In North Up mode, the chart orientation is fixed with true north upwards. As your heading changes the vessel symbol moves accordingly. This is the default mode for the chart application.

Head Up (H-up)

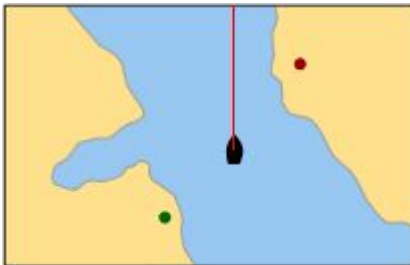

Head Up mode displays the chart with your vessel's current heading upwards. As the heading changes the vessel symbol remains fixed and the chart picture rotates accordingly.

Note: To prevent continuous backwards and forwards rotations as the vessel yaws from side-to-side, the chart will not update unless the heading changes by at least 10 degrees from the last displayed orientation.

Note: It is not possible to select Head Up when the motion mode is set to True.

Course Up (C-up)

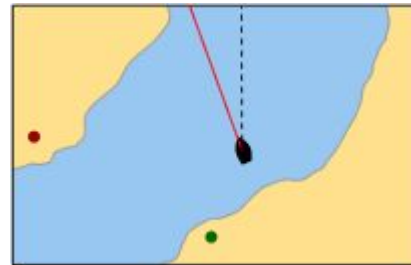

In Course Up mode, the chart picture is stabilized and shown with your current course upwards. As your vessel's heading changes, the ship symbol moves accordingly. If you select a new course, the picture will reset to display the new course upwards. The reference used for Course-Up depends upon the information available at a given time. The system always prioritizes this information in the following order:

1. Bearing from origin to destination, i.e. intended course.
2. Locked heading from an Autopilot.
3. Bearing to waypoint.
4. Instantaneous heading.

If heading data becomes unavailable whilst in this mode, a warning message will be shown and the chart uses 0° heading in relative motion.

Setting the chart orientation

In the chart application:

1. Press the **MENU** button.

2. Select **Chart Setup**.
3. Use the **Chart Orientation** menu item to select the Head-Up, North-Up, or Course-Up option, as appropriate.

Chart motion mode

The motion mode controls the relationship between the chart and your vessel.

Whilst motion mode is active, as your vessel moves, the chart is redrawn to keep the vessel on-screen. The 3 motion modes are:

- Relative Motion.
- True Motion.
- Autorange.

Note: In the 3D chart view, the only available motion mode is Relative Motion.

The current motion mode applies to all instances of the chart application, including those running on networked displays.

When you pan the chart or select **FIND CURSOR**, the motion mode is no longer active. This is indicated in the status bar by brackets around the motion mode — for example, (RM). This enables you to view another area of the chart whilst navigating. To reset the motion mode and return your vessel to the screen, select **FIND SHIP**. Manually changing the range in autorange also suspends motion mode. The default setting is relative motion with zero offset. The mode that you select is restored at power up.

Relative Motion with optional vessel offset

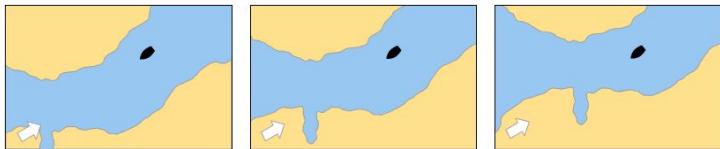

When the motion mode is set to Relative, the position of your vessel is fixed on the screen and the chart picture moves relative to your vessel. You can use the **MENU > Chart Setup > Vessel Offset** menu item to determine whether the vessel is fixed in the centre of the window (0 offset) or offset by 1/3 or 2/3. If you change the offset to 1/3 or 2/3, the view ahead of your vessel will be increased.

In the example shown above, the motion mode has been set to Relative, with a vessel offset of 1/3. The vessel is fixed in the offset position and the chart moves accordingly:

True Motion

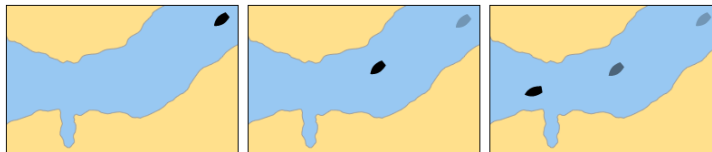

When the motion mode is set to True, the chart is fixed and the vessel moves in true perspective to fixed landmasses on the screen. As the vessel's position approaches the edge of the screen, the chart picture is automatically reset to reveal the area ahead of the vessel.

Note: It is not possible to select True Motion when the orientation is set to Head Up.

Autorange

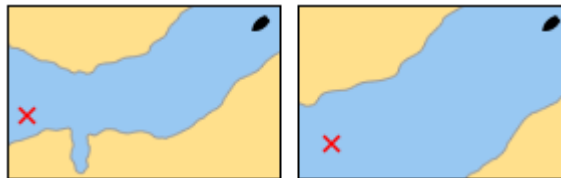

Autorange selects and maintains the largest possible scale of chart that will display both the vessel and the target waypoint. Autorange is not available if radar-chart synchronization is on.

Setting the motion mode

In the chart application:

1. Press the **MENU** button.
2. Select **Chart Setup**.
3. Use the **Motion Mode** menu item to select the appropriate option.

Changing the vessel offset value

In the chart application:

1. Press the **MENU** button.
2. Select **Chart Setup**.
3. Use the **Vessel Offset** menu item to select the 0, 1/3, or 2/3 option, as appropriate.

Locating your vessel

In the chart application:

1. Press the **FIND** softkey and select the SHIP option.
Your vessel is displayed in the center of the chart.
2. To mark this position, press the **WPTS MOB** button twice, then press the **OK** button.

6.3 Chart views

The chart is viewed and manipulated in 3 dimensions. It can be viewed from directly overhead (2D view) or at an angle (3D view)

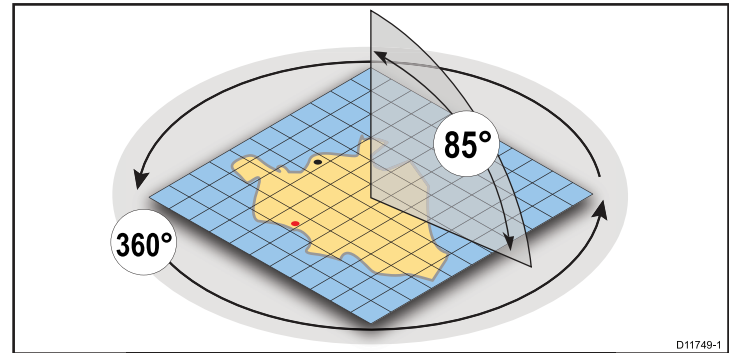

- **2D chart view.** The chart automatically reverts to 2D mode when viewed directly from above.
- **3D chart view.** The chart operates in 3D mode whenever it is not viewed directly from above.

2D chart view

The 2D chart view displays a range of information to help you navigate.

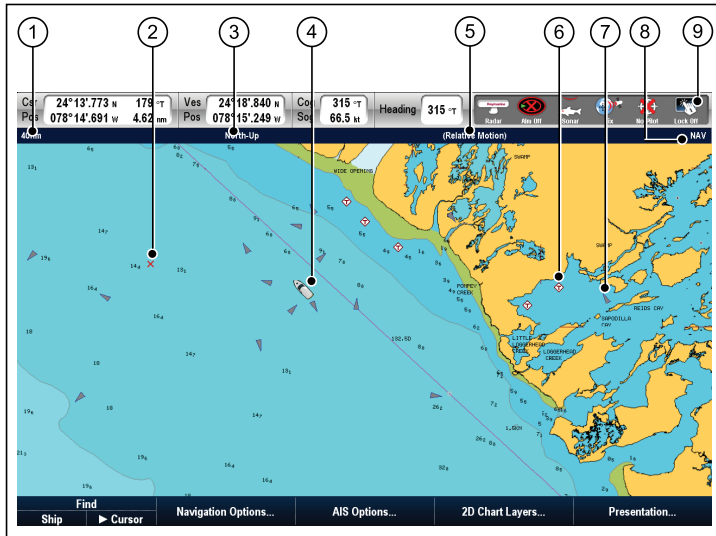

| Item | Description |
|------|--|
| 5 | Motion mode — states the current motion mode (Relative, True, or Autorange). |
| 6 | Cartographic objects — use the Cartography Setup menu to choose which objects to display. |
| 7 | AIS target — a vessel broadcasting AIS information. |
| 8 | Chart type — indicates the type of chart in use — Fish or Navigation. |
| 9 | Status bar — displays the status of externally connected equipment. |

| Item | Description |
|------|--|
| 1 | Range — horizontal distance across screen (halfway up the window or at center-of-view). Shown in selected system units. |
| 2 | Waypoint — with arrival circle. |
| 3 | Orientation — states the orientation mode that the chart is using (North-up, Head-up, or Course-up). |
| 4 | Vessel symbol — shows your current position. |

3D chart view

The 3D chart view includes a number of functions to help you navigate your vessel.

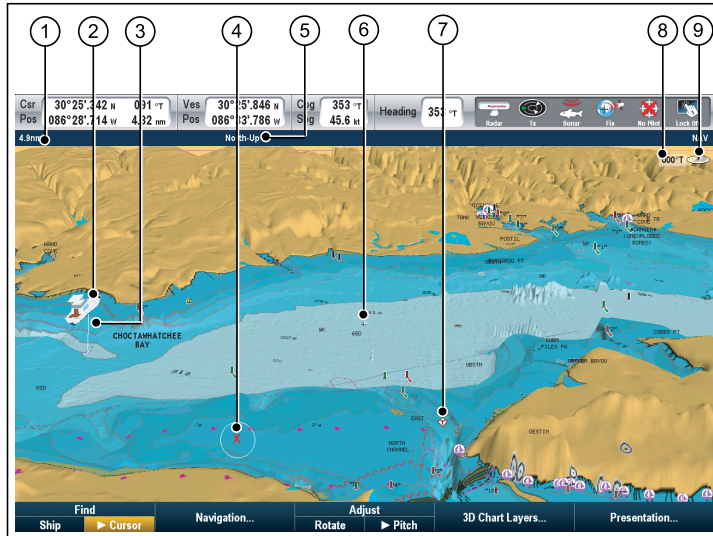



| Item | Description |
|------|--|
| 1 | Range — horizontal distance across screen (halfway up the window or at center of view). Shown in selected system units. |
| 2 | Vessel symbol — your vessel's current position. |
| 3 | Depth Scale — approximate depth beneath your vessel. |
| 4 | Waypoint — with arrival circle. |
| 5 | Orientation — states the orientation mode that the chart is using. |

| Item | Description |
|------|---|
| 6 | Center-of-view — the white cross indicates the center of chart view at the water level. |
| 7 | Cartographic objects — use the Cartography Setup menu to choose which objects to display. |
| 8 | Rotation — shows in degrees true, how far the on-screen view has been rotated from your vessel's heading. |
| 9 | North arrow — 3D indication of True North in relation to the chart view. The north arrow also tilts to indicate pitch angle. |

Manipulating the chart view

Use a combination of the UniControl and range keys to manipulate the chart view.

| | |
|---|---|
|  | UniControl — is used for pitch, rotate and pan. |
|  | Range key— is used to zoom in and out. |

1. Chart pitch.

- i. If the chart is in 3D mode, select the **Pitch** option from the softkey toolbar
- ii. Use the rotary control to change the pitch angle of the chart display.

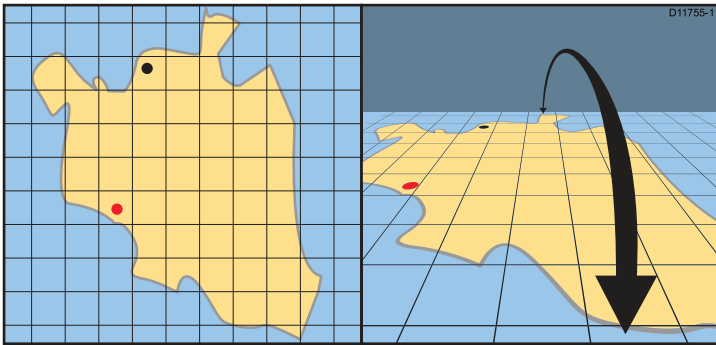

1. Swipe your finger across the display in the direction you want to pan the chart.

Switching between 2D/3D chart view

You can quickly toggle between 2D and 3D views.

In the chart application:

1. Select the **PRESENTATION** softkey.
2. Select the 2D or 3D option, using the **VIEW** softkey.

2. **Rotate** (only available when the chart is in 3D mode)
 - i. Select the **Rotate** option from the softkey toolbar
 - ii. Use the rotary dial on the UniControl to rotate the chart display.

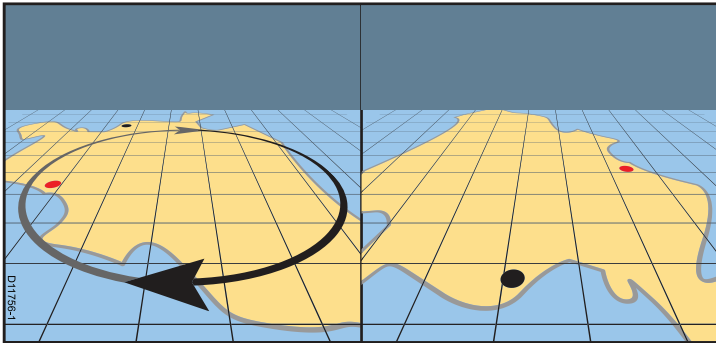

3. **Zoom**— Use the range key to zoom in or out of the chart.
4. **Pan**— Use the trackpad on the UniControl to pan the chart.

Panning the chart using touch

In the chart application:

6.4 Chart planning options

The chart provides features to help plan your navigation to a chosen location.

The options are found on the chart softkeys — **Navigation options > Planning**.

- **Build new route** — Allows you to build a route using a series of waypoints.
- **My Routes** — View and edit routes stored on the system.
- **My Tracks** — View and edit tracks stored on the system. Start or stop a track.
- **My Waypoints** — View and edit waypoints stored on the system.

6.5 Chart navigation options

The chart provides features to help navigate to a chosen location.

The **Navigation Options** are found on the chart toolbar softkeys — **Navigation options>Navigation**

- **Ruler** — Provides options to measure distance
- **Goto Cursor** — Will set the cursor position as the active destination.
- **Follow Route Options...** — Provides options to navigate to a route stored on the system
- **Goto Waypoint options** — Provides options to navigate to a waypoint stored on the system
- **Start Track** — Will initiate a track on screen to retrospectively plot your course as you progress.

6.6 Measuring distances and bearings

You can use the databar information and the ruler to measure distances in the chart application.

You can determine the distance and bearing:

- from your boat to the position of the cursor;
- between two points on the chart.

Note: You must have Cursor Position data displayed in the databar when making measurements. Go to **MENU > Databar Setup > Configure** to customize the databar.

Positioning the chart ruler

In the chart application:

1. Position the cursor at the start point of your measurement or bearing.
2. Select the **NAVIGATION** softkey.
3. Select the **RULER** softkey.
4. Position the cursor at the end point of your measurement or bearing. The range and bearing is displayed.
5. Press the **OK** button to fix the new ruler position.

Repositioning the chart ruler

In the chart application, with the ruler displayed:

1. Select the **NAVIGATION** softkey.
2. Select the **RULER** softkey.
3. Use the **ADJUST A** or **ADJUST B** softkey to select the start or end point, as appropriate.
4. Move the cursor to the new ruler position.
5. Press the **OK** button to fix the new ruler position.

Clearing the chart ruler

In the chart application:

1. Select the **NAVIGATION** softkey.
2. Select the **RULER** softkey.
3. Select the **CLEAR RULER** softkey.

6.7 Chart vectors

Chart vectors display indicators for heading and COG, and wind and tide direction.

A range of vector graphics can be superimposed on to the chart display. The following vectors can be independently enabled or disabled in the **2D set up** menu, accessible from the **Chart Setup Menu**:

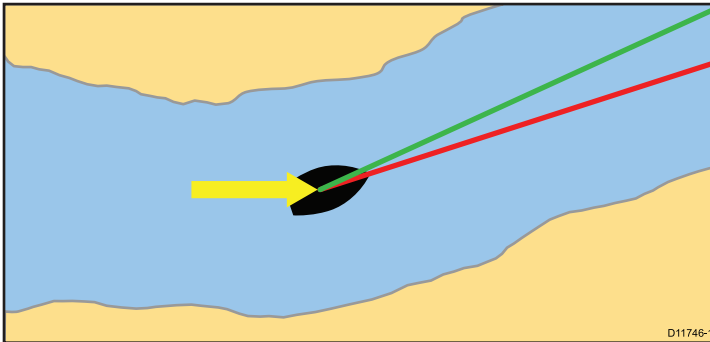

Note: If neither Speed Over Ground (SOG) or heading data is available, vectors cannot be displayed.

Vector length

The length of the HDG and COG vector lines is determined by the distance your vessel will travel in the time you have specified (3 mins, 6 mins or Infinite) in the **Chart Setup Menu** at the current speed. Any times that you specify will apply to all chart views, and if the Infinite option is selected, the vector will extend to the edge of the chart window.

Enabling and disabling chart vectors

In the 2D chart view:

1. Press the **MENU** button.
2. Select **Chart Setup**.
3. Select **2D set up**.
4. Select the ON or OFF option for the **Heading Vector**, **COG Vector**, **Tide Arrow**, or **Wind Arrow** menu items, as appropriate.

Vector descriptions

HDG (heading) vector — a red line shows the vessel's heading. An arrow head is used if the vector length is set to a value other than infinite.

COG (Course Over Ground) vector — a green line indicates the vessel's actual course. A double arrow head is used if the vector length is set to a value other than infinite.

Tide arrow — tide is displayed as a blue line with solid arrow head pointing away from your vessel, in the direction of the tidal set. The width of the arrow indicates the tide strength.

Wind arrow — wind direction is displayed as a yellow line with solid arrow heads pointing towards your vessel, indicating the wind direction. The width of the arrow indicates the wind strength.

6.8 Current information

Animated current information

The electronic charts may allow animation of the current information current stations.

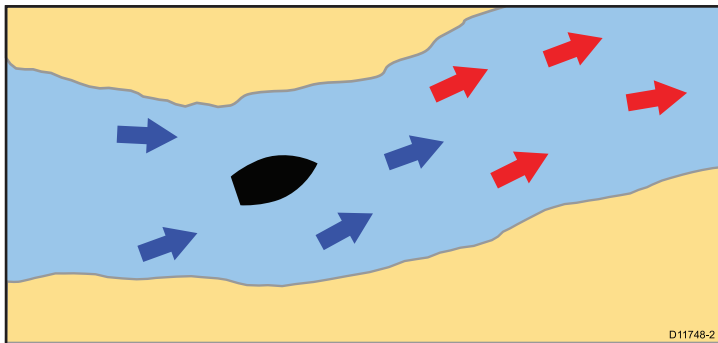

Animated current information is available in the chart application wherever a diamond-shaped symbol with a "C" is displayed:

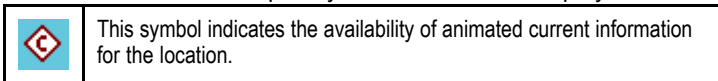

When you position the cursor over a current symbol the softkeys change to provide the animation options.

When you select the **ANIMATE** softkey the diamond-shaped current symbols are replaced with dynamic current arrows which indicate the direction and strength of the currents:

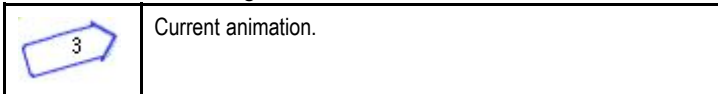

- Arrows indicate the direction of current flows.
- The length of the arrow indicates the flow rate.

- The color of the arrow indicates the flow speed:
 - **Red**: increasing current flow speed.
 - **Blue**: decreasing current flow speed.

The animation can be viewed continuously or incrementally for a time period that you specify. You can also set the date for the animation, and start or restart the animation at any point within a 24-hour period. If the system does not have a valid date and time the date used will be midday for the system default date.

Note: Not all electronic charts support the animated currents feature.

Viewing animated current information

In the chart application:

1. Position the cursor over a diamond-shaped current icon.
2. Press the **OK** button to display the Object Info dialog box.
The softkeys change to provide current-related options.
3. Select the **Animate** softkey.
The softkeys change to provide animation options.

Controlling animations

In the chart application, with an animation displayed:

1. To start or stop the animation, select the **ANIMATION PLAY / PAUSE** softkey.
2. To view the animation in steps, select the **STEP BACK** or **STEP FWD** softkeys.
3. To set the animation step interval, pause any playing animations, and then select the **SET TIME INTERVAL** softkey.
4. To set the animation date, select the **SET DATE** softkey. The Edit Date screen shows the following options:

| | |
|---------------------|---|
| TODAY'S DATE | Set the animation date to the current date. |
| PREV DATE | Set the animation date to 24-hours previous to current date. |
| NEXT DATE | Set the animation date to 24-hours ahead of current date. |
| EDIT DATE | Opens the Edit Date pop-up screen: use the trackpad or rotary control to enter the date for which you want to see an animation. |

5. Press **OK** to save the new date and return to the animation, or **CANCEL** to ignore the date change and return to the animation, leaving the date setting unchanged.

Displaying details of currents

In the chart application:

1. Position the cursor over the diamond-shaped current symbol.
The softkeys change to provide current-related options.
2. Press the **OK** button to display information for that current.
3. Select the **VIEW CURRENT STATION** softkey.
4. To move the time selector, use the trackpad.
5. To change the displayed date, use the appropriate softkeys.

6.9 Tide information

Animated tide information

The electronic charts may allow animation of the tide information tide stations.

Animated current information is available in the chart application wherever a diamond-shaped symbol with a "T" is displayed:

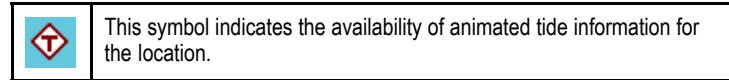

When you position the cursor over a tide symbol the softkeys change to provide the animation options.

When you select the **ANIMATE** softkey the diamond-shaped tide symbols are replaced with the dynamic tide bar which indicates the predicted tide height for the actual time and date:



- Tide height is indicated by a gauge. The gauge is comprised of 8 levels, which are set according to the absolute minimum / maximum values of that particular day.
- The color of the arrow on the tide gauges indicates changes in the tide height:
 - **Red**: increasing tide height.
 - **Blue**: decreasing tide height.

The animation can be viewed continuously or incrementally for a time period that you specify. You can also set the date for the animation, and start or restart the animation at any point within a 24-hour period. If the system does not have a valid date and time the date used will be midday for the system default date.

Note: Not all electronic charts support the animated tides feature.

Viewing animated tide information

In the chart application:

1. Position the cursor over a diamond-shaped tide icon.
2. Press the **OK** button to display the Object Info dialog box.
The softkeys change to provide tide-related options.
3. Select the **Animate** softkey.
The softkeys change to provide animation options.

Controlling animations

In the chart application, with an animation displayed:

1. To start or stop the animation, select the **ANIMATION PLAY / PAUSE** softkey.
2. To view the animation in steps, select the **STEP BACK** or **STEP FWD** softkeys.
3. To set the animation step interval, pause any playing animations, and then select the **SET TIME INTERVAL** softkey.
4. To set the animation date, select the **SET DATE** softkey. The Edit Date screen shows the following options:

| | |
|---------------------|---|
| TODAY'S DATE | Set the animation date to the current date. |
| PREV DATE | Set the animation date to 24-hours previous to current date. |
| NEXT DATE | Set the animation date to 24-hours ahead of current date. |
| EDIT DATE | Opens the Edit Date pop-up screen: use the trackpad or rotary control to enter the date for which you want to see an animation. |

5. Press **OK** to save the new date and return to the animation, or **CANCEL** to ignore the date change and return to the animation, leaving the date setting unchanged.

Displaying details of tides

In the chart application:

1. Position the cursor over the diamond-shaped tide symbol.
2. Press the **OK** button to display information for that tide.
The softkeys change to provide tide-related options.
3. Select the **VIEW TIDE STATION** softkey.
4. To move the time selector, use the trackpad or rotary control.
5. To change the displayed date, use the appropriate softkeys.

6.10 Chart object information

You can display additional information on the chart for cartographic objects, ports, and marinas.

You can also search for the nearest instance of a particular chart object and search for ports by name.

Depending on the chart card you are using, you can view some or all of the following additional information:

- Details of each cartographic object that is marked on the chart, including source data for structures, lines, open sea areas, and so on.
- Details of ports, port features, and business services.
- Pilot book information (similar to what you would see in a marine almanac). Pilot book information is available at certain ports.
- Panoramic photos of ports and marinas. The availability of photos is indicated by a camera symbol on the chart display.

There are 2 main ways of accessing object information:

- **At any time** — by pressing the **OK** button. This provides a list of chart objects, and access to the **FIND NEAREST** and **SEARCH BY NAME** softkeys.
- **Using an object on the screen** — placing the cursor over the object and pressing **OK** provides information specific to that object, and access to the **FIND NEAREST** and **SEARCH BY NAME** options.

Note: The amount of object information available depends upon the electronic charts that you are using for your system. For full details of the features available for your chart cards contact your chart card supplier.

Displaying chart object information

In the chart application:

Using the chart

1. Position the cursor over the object.
A pop-up is displayed, showing the basic object information.
2. Press the **OK** button.
Detailed information for that object is displayed, and the softkeys change to provide the **FIND NEAREST** and **SEARCH BY NAME** options.
3. If the object information includes more than one subject area, use the rotary control to highlight and select the required information.

Searching for the nearest chart object by type

In the chart application:

1. Press the **OK** button.
The softkeys change to provide the object search options.
2. Select the **FIND NEAREST** softkey.
A list of chart object types is displayed.
3. Highlight the chart object in the list.
4. Press the **OK** button.
A list is displayed of the available instances of that particular chart object.
5. Highlight the chart object instance that you want to find.
6. Select the **SHOW ON CHART** softkey.

Searching for a port by name

In the chart application:

1. Press the **OK** button.
The softkeys change to provide the search object options.
2. Select the **SEARCH BY NAME** softkey.
3. Select the **EDIT NAME** softkey.
The on-screen keyboard is displayed.
4. Use the on-screen keyboard to enter the desired port name.

5. Select the **SEARCH** softkey.
The search results are displayed.
6. Select an entry in the list to display more information.

Displaying pilot book information

In the chart application, when a port symbol is displayed:

1. Position the cursor over the port symbol.
2. Press the **OK** button.
The Object Info dialog is displayed.
3. Select the **Pilot Book** menu item.
4. Highlight the relevant book or chapter.
5. Select the **VIEW PILOT BOOK** softkey.

Displaying panoramic photos

In the chart application, when a camera symbol is displayed, indicating the availability of a photo:

1. Position the cursor over the camera symbol.
2. Press the **OK** button.
3. Select the **VIEW PHOTO** softkey.

6.11 Chart layers

The chart has a number of content layers and display modes providing different kinds of display and information.

You can overlay data onto a chart window to give greater depth of information. The overlays available are:

- Aerial overlay. Provides an aerial / satellite photography overlay.
- NowRad weather (2D view only) — Provides the NowRad weather radar overlay, without the need to open a separate weather application window.
- Weather reports (2D view only) — Provides weather reports, without the need to open a separate weather application window.
- Radar overlay (2D view only) — Overlay radar onto the chart.
- AIS Targets (2D view only) — View and track AIS targets.
- Adjust Exaggeration (3D view only) — Adjust the 3D relief.
- Waypoint names (3D view only) — View waypoint names on the chart.

Note: The layers require electronic charts with the appropriate feature support and may also require additional hardware and service subscriptions.

Aerial photo overlay

Your electronic charts may include aerial photography.



Aerial photos cover the navigable waters up to 3 miles inside the coastline. The resolution is dependent on the region covered by the chart card.

Enabling aerial photo overlay

In the chart view:

1. Select the **2D CHART LAYERS** or **3D CHART LAYERS** softkey as appropriate.
2. Use the **AERIAL OVERLAY** softkey to select the ON option.

Using the chart

Specifying aerial overlay opacity

In the 2D chart view:

1. Select the **2D CHART LAYERS** softkey.
2. Use the **AERIAL OVERLAY** softkey to select the ON option. The opacity bar is displayed above the softkey.
3. Use the rotary control to adjust the opacity, between 1 and 100%.

Specifying the aerial overlay area

In the chart application, with aerial photo overlay enabled:

1. Press the **MENU** button.
2. Select the **Cartography Setup** menu item.
3. Select the **Aerial Photo Overlay** menu item.
4. Select the On Land or On Land and Sea option, as appropriate.
5. Press the **OK** button.

3D chart detail exaggeration

You can exaggerate the vertical size of objects on the 3D chart to make it easier to interpret what you are seeing.

Sometimes it is easier to see certain topographical features if they are exaggerated. Adjusting the exaggeration has the effect of vertically stretching objects on the chart, making it easier to see their shape and position. This could be particularly helpful if you are fishing, for example.

Adjusting the 3D chart exaggeration

In the 3D chart view:

1. Select the **PRESENTATION** softkey.
2. Select the **3D VIEW OPTIONS** softkey.
3. Select the **ADJUST EXAGGERATION** softkey.
4. Using the trackpad, select the required amount of exaggeration.

Radar overlay

You can combine the chart with the radar and MARPA functions to provide target tracking or to help you distinguish between fixed objects and other marine traffic.

You can enhance the use of your chart by combining it with the following radar features:

- MARPA.
- Radar overlay (for distinguishing between fixed and moving objects).

Using the radar to view MARPA targets on the chart

The Mini Automatic Radar Plotting Aid (MARPA) function is used for target tracking and risk analysis. When the radar overlay is on, all MARPA targets are displayed in the chart window and associated MARPA functions can be accessed via the chart.

Using radar overlay to distinguish between fixed and moving objects

You can overlay radar image data over your chart image allowing better distinction between fixed objects and other marine traffic. For best results, switch on Radar-Chart synchronization to ensure radar range and chart scale are synchronized.

Enabling radar overlay

In the 2D chart view:

1. Select the **2D CHART LAYERS** softkey.
2. Use the **RADAR OVERLAY** softkey to select the ON option.

Accessing MARPA controls on the chart

In the chart application:

1. Select the target using the cursor.
The MARPA-related softkeys are displayed.
2. Alternatively, with Radar Overlay switched on, press the **TARGET TRACKING** softkey.

Chart scale and radar range synchronization

You can synchronize the radar range in all radar windows with the chart scale.

When synchronization is switched on:

- The radar range in all radar windows changes to match the chart scale.
- 'Sync' is indicated in the top left-hand corner of the chart window.
- If you change the radar range, in any radar window, all synchronized chart views change scale to match.
- If you change the scale of a synchronized chart window, all radar windows change range to match.

Synchronizing the chart and radar range

In the 2D chart view:

1. Select the **PRESENTATION** softkey.
2. Use the **SYNC** softkey to select the RDR option.
3. Use the **RANGE IN** or **OUT** control to change the chart and radar range.

Note: Radar range synchronization is not available when the chart motion mode is set to AUTORANGE.

Range rings

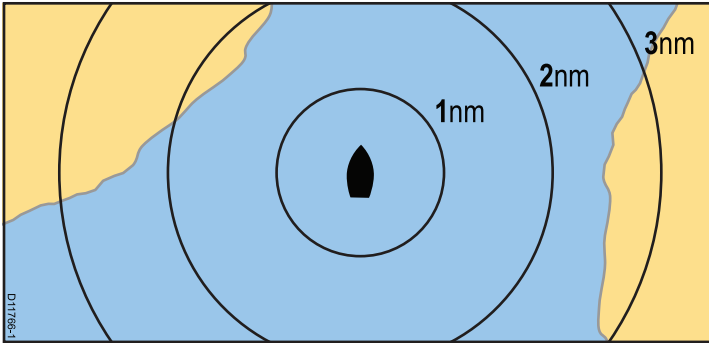

Range rings give you an incremental representation of distance from your vessel to help you judge distances at a glance. The rings are always centred on your vessel, and the scale varies to suit your current zoom setting. Each ring is labelled with the distance from your vessel.

Enabling range rings

In the 2D chart view:

1. Press the **MENU** button.
2. Select **Chart Setup**.
3. Select **2D Set Up**.
4. Select the ON option for the **2D Range Rings** menu item.

NOWRad weather overlay

With a suitable weather receiver connected to your multifunction display, you can overlay NOWRad weather information on the chart display.

The NOWRad weather overlay provides NOWRad weather information and reports in the chart application. You can adjust the intensity of the overlay to achieve optimal visibility of both chart and weather information.

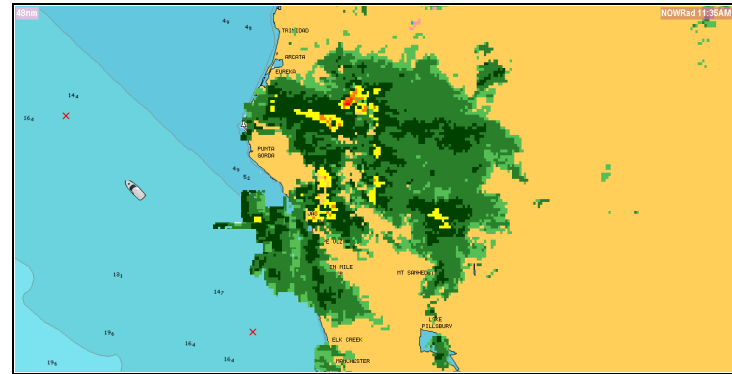

Note: The NOWRad weather overlay can only be used in North America and its coastal waters.

Enabling NOWRad weather overlay on the chart

In the 2D chart view:

1. Select the **2D CHART LAYERS** softkey.
2. Select the ON option using the **NOWRAD OVERLAY** softkey.

Choosing weather reports for display on the chart

In the 2D chart view:

1. Select the **2D CHART LAYERS** softkey.
2. Select the **WEATHER REPORTS** softkey.

3. Use the **TROPICAL STATEMENTS**, **MARINE WARNINGS**, **MARINE ZONE FORECASTS**, or **WATCHBOX WARNINGS** softkeys to select the required weather reports.

6.12 Chart presentation

The chart has a number of presentation options which affect the level of detail, types of objects and aspects of its operation.

The presentation options available are:

- **Sync** — Synchronize the radar and chart scales.
- **Chart detail** — Set the level of object detail shown on the chart.
- **Chart type** — Select fishing charts (if supported by your chosen chart supplier).
- **View** — Toggle 2D and 3D perspective view.

Accessing chart presentation options

In the chart application:

1. Select the **PRESENTATION** softkey.
2. Use the softkey toolbar to set the required options.

Multiple chart synchronization

You can synchronize the heading, range, and position information across multiple chart views and networked displays (SeaTalk^{hs}).

When chart synchronization is enabled:

- It is indicated by “Chart Sync” in the chart application status bar.
- Some softkey functions are not available with this feature, and are “grayed-out”.
- Any changes made to the heading, range or position in any chart instance will be reflected in all other chart instances.

Note: When the 2D and 3D chart views are synchronized, the Motion Mode is always Relative Motion.

Synchronizing multiple chart instances

In the chart application:

1. Select the **PRESENTATION** softkey.

2. Use the **SYNC** softkey to select the CHRT option.
3. If you have networked displays, repeat Step 2 in the chart application on each display that you want to synchronize.

Fish mode

Fish mode provides bathymetric contour data on the chart for use during fishing.

Before you can display bathymetric data in the chart application you must have chart cards with the relevant level of detail.

When you change the **CHART TYPE** to the FISH option, bathymetric data is shown on the chart (providing that the chart card contains bathymetric data for that particular location). Certain chart detail is also removed to ensure the bathymetric data can be seen clearly on the chart display.

If the chart card does NOT contain bathymetric data the chart reverts to the default NAV (navigation) data.

Enabling Fish mode

In the chart application:

1. Select the **PRESENTATION** softkey.
2. Select the **CHART TYPE** softkey .
3. Use the **CHART USE** softkey to select the FISH option.

Note: The CHART USE softkey is disabled if your cartography does NOT support the feature.

Chart Detail

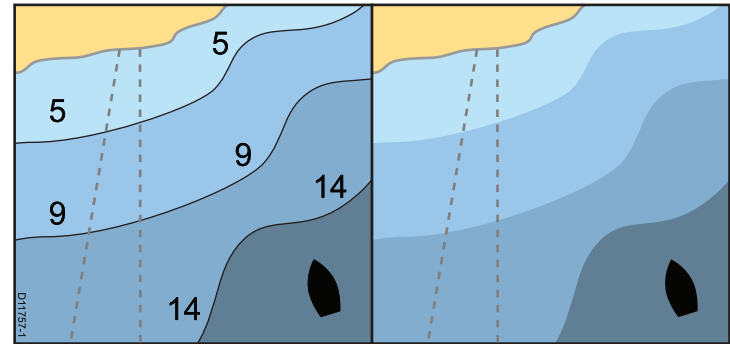

The chart detail setting determines the amount of cartographic detail shown in the chart application.

Selecting the LOW option for the **CHART DETAIL** softkey hides the following cartographic objects:

- Text.
- Chart boundaries.
- Spot soundings.
- Depth contours.
- Light sectors.
- Caution and routing Data.
- Land and marine features.
- Business services (if available for your chart card).

Selecting the HIGH option shows these objects.

Changing the level of chart detail

In the chart application:

1. Select the **PRESENTATION** softkey.

2. Use the **CHART DETAIL** softkey to select the HIGH or LOW option, as appropriate.

6.13 Chart setup

The set up for your chart and its cartography can be changed from the standard configuration to suit your particular needs.

Although you will probably only do this when you first use the chart, you may decide to make subsequent adjustments once you become more familiar with the system. Any settings that you change are retained even when you power off.

Selecting the chart setup menu

In the chart application:

1. Press the **MENU** button.
2. Select the **Chart Setup** menu item.
The Chart Setup Menu is displayed.

Chart setup menu options

The following table describes the various options in the Chart Setup Menu for your multifunction display.

| Menu item | Description | Options |
|--------------------------|--|---|
| Chart Orientation | Chart orientation is the relationship between the chart and the direction that you are travelling in. This menu option enables you to choose the orientation. | <ul style="list-style-type: none">• Head-Up• North-Up (default)• Course-Up |
| 2D Motion Mode | The motion mode controls the relationship between the chart and your vessel. This setting only applies to the 2D chart view. The 3D chart view is always set to Relative Motion, regardless of the setting you specify here. | <ul style="list-style-type: none">• Relative Motion (default)• True Motion• Autorange |
| Vessel Offset | Determines whether the vessel is fixed in the center of the window (0 offset) or offset by 1/3 or 2/3. The 1/3 or 2/3 options provide a better view ahead of your vessel. | <ul style="list-style-type: none">• 0 (default)• 1/3• 2/3 |
| Vessel Icon Type | Determines the type of vessel icon displayed in the chart application. | <ul style="list-style-type: none">• Sail (default)• Power |
| Vessel Icon Size | Determines the size of vessel icon displayed in the chart application. | <ul style="list-style-type: none">• Small (default)• Large |

| Menu item | Description | Options |
|-----------|---|---|
| 3D set up | <p>Settings specific to the 3D chart view:</p> <ul style="list-style-type: none"> • Center-of-view indicator — determines whether a white cross is displayed, indicating the centre of view. • Trans Cone — displays a transducer cone below the vessel icon, indicating the approximate scope of the fishfinder coverage. • Depth Scale — displays a scale below the vessel icon, indicating the approximate depth of the water underneath your vessel. | <ul style="list-style-type: none"> • Center-of-view indicator: <ul style="list-style-type: none"> – ON – OFF (default) • Trans Cone: <ul style="list-style-type: none"> – ON – OFF (default) • Depth Scale: <ul style="list-style-type: none"> – ON – OFF (default) |
| 2D set up | <p>Settings specific to the 2D chart view:</p> <ul style="list-style-type: none"> • Heading Vector — displays a red vector line from your vessel icon, indicating your current heading. The length of the line depends on the value you specify for the Vector Length setting. • COG Vector — displays a green vector line from your vessel icon, indicating your current Course Over Ground (COG) bearing. The length of the line depends on the value you specify for the Vector Length setting. • Tide Arrow — displays a blue animated arrow indicating the direction of tides. The width of the arrow indicates the tide strength. • Wind Arrow — displays a yellow animated arrow indicating the wind direction. The width of the arrow indicates the wind strength. • Vector Length — the distance your vessel travels in the time period specified for this option, determines the length of the vector lines drawn on the chart display. This affects COG and HDG (heading) vectors. If the Infinite option is selected, the vector will extend to the edge of the chart window. | <ul style="list-style-type: none"> • Heading Vector: <ul style="list-style-type: none"> – ON – OFF (default) • COG Vector: <ul style="list-style-type: none"> – ON – OFF (default) • Tide Arrow: <ul style="list-style-type: none"> – ON – OFF (default) • Wind Arrow: <ul style="list-style-type: none"> – ON – OFF (default) • Vector Length: |

| Menu item | Description | Options |
|---------------------------|---|---|
| | <ul style="list-style-type: none"> • Vector Width — sets the width of the COG and HDG (heading) chart vector lines. • Route Width — sets the width of route lines. • Range Rings — displays radar range rings on the chart display. | <ul style="list-style-type: none"> – 3 Mins – 6 Mins – Infinite (default) • Vector Width: <ul style="list-style-type: none"> – Thin – Normal (default) – Wide • Route Width: <ul style="list-style-type: none"> – Thin – Normal (default) – Wide • Range Rings: <ul style="list-style-type: none"> – ON – OFF (default) |
| Object Information | <p>Determines how further information is accessed for cartographic areas and objects:</p> <ul style="list-style-type: none"> • OFF — information is displayed for a cartographic object when you move the cursor over the object and press the OK button. • ALL ON — information is displayed for cartographic objects and areas when you move the cursor over an object or area. • Points ON — information is displayed for a cartographic object when you move the cursor over the object. | <ul style="list-style-type: none"> • OFF • Points ON • All ON (default) |

| Menu item | Description | Options |
|-------------------------------|--|--|
| Record Vessel Track By | <p>Determines how track points are recorded on the chart:</p> <ul style="list-style-type: none"> • Auto — track points are automatically created. • Time — track points are created based on time. • Distance — track points are created based on distance. | <ul style="list-style-type: none"> • Auto (default) • Time • Distance |
| Track Interval | <p>Determines the interval that will be used for track point creation. The options available depend on the option selected for the Record Vessel Track By menu item, as follows:</p> <ul style="list-style-type: none"> • Auto — if the Auto option is selected for the Record Vessel Track By menu item, no options are available for the Track Interval menu item. • Time — if the Time option is selected for the Record Vessel Track By menu item, you can use the Track Interval menu item to specify the time interval. • Distance — if the Distance option is selected for the Record Vessel Track By menu item, you can use the Track Interval menu item to specify the distance interval. The units used for this setting depend on the setting made for Distance Units in the MENU > System Setup > Units Setup menu. | <p>If TIME is selected for the Record Vessel Track By menu item:</p> <ul style="list-style-type: none"> • 2 secs • 5 secs • 10 secs • 30 secs • 1 min • 3 min • 5 min • 10 min • 30 min <p>If DISTANCE is selected for the Record Vessel Track By menu item:</p> <ul style="list-style-type: none"> • 0.02 nm / sm / km • 0.05 nm / sm / km • 0.1 nm / sm / km • 0.2 nm / sm / km • 0.5 nm / sm / km |

| Menu item | Description | Options |
|---------------------|--|--|
| | | <ul style="list-style-type: none"> • 1.0 nm / sm / km |
| System Datum | <p>In order for your GPS and chart to correlate accurately with your paper charts, they must be using the same datum. The default datum for your display is WGS1984. If this is not suitable, you can change the setting. When you change the datum setting, the chart grid will subsequently move according to the new datum, and the latitude/longitude of the cartographic features will also change accordingly. The system attempts to set up any GPS to the new mode, and indicates whether this was successful or not.</p> <div style="border: 1px solid black; padding: 5px; margin-top: 10px;"> <p>Note: Raymarine recommends that you check the displayed vessel position in the chart application against your actual proximity to a known charted object. A typical GPS has an accuracy of between 5 and 15 m.</p> </div> | <ul style="list-style-type: none"> • WGS1984 (default) • List of available datum |

Selecting the cartography setup menu

In the chart application:

1. Press the **MENU** button.
2. Select the **Cartography Setup** menu item.

Cartography setup menu options

The following table describes the various options in the Cartography Setup Menu for your multifunction display.

| Menu item | Description | Options |
|-------------------------|--|--|
| Chart Display | Determines the level of detail shown on the chart. | <ul style="list-style-type: none">• Simple• Detailed (default)• Extra Detailed |
| Chart Grid | Determines whether grid lines representing longitude and latitude are displayed on the chart: <ul style="list-style-type: none">• OFF — grid lines are NOT displayed.• ON — grid lines are displayed. | <ul style="list-style-type: none">• OFF• ON (default) |
| Chart Text | Determines whether chart text is displayed (place names and so on). <ul style="list-style-type: none">• OFF — chart text is NOT displayed.• ON — chart text is displayed. | <ul style="list-style-type: none">• OFF• ON (default) |
| Chart Boundaries | Determines whether a line indicating the chart boundary is displayed. <ul style="list-style-type: none">• OFF — chart boundary is NOT displayed.• ON — chart boundary is displayed. | <ul style="list-style-type: none">• OFF• ON (default) |
| Spot Soundings | Determines whether a number indicating depth is displayed. <ul style="list-style-type: none">• OFF — depth is NOT displayed.• ON — depth is displayed. | <ul style="list-style-type: none">• OFF• ON (default) |

| Menu item | Description | Options |
|---------------------------|--|--|
| Safety Contour | The chart will use this depth as the deep water boundary. Water areas of depth greater than this will be colored using the appropriate Deep Water Color . | <ul style="list-style-type: none"> • OFF • 7 ft • 10 ft • 16 ft • 20 ft • 33 ft • 66 ft (default) |
| Depth Contour | The depth contour is shown on the chart display as a line indicating the depth at a particular position. | <ul style="list-style-type: none"> • OFF • 16 ft • 20 ft • 33 ft • 66 ft • ALL (default) |
| Nav. Marks | Determines whether navigation marks are displayed on the chart: <ul style="list-style-type: none"> • OFF — navigation marks are NOT displayed. • ON — navigation marks are displayed. | <ul style="list-style-type: none"> • OFF • ON (default) |
| Nav. Marks Symbols | Determines which set of navigation mark symbols is used — International, or US. These symbols correspond to paper charts. | <ul style="list-style-type: none"> • International (default) • US |
| Light Sectors | Determines whether the sector of light cast by a fixed beacon is displayed or not. <ul style="list-style-type: none"> • OFF — sector of light is NOT displayed. • ON — sector of light is displayed. | <ul style="list-style-type: none"> • OFF • ON (default) |

| Menu item | Description | Options |
|-----------------------------------|--|---|
| Caution & Routing Data | Determines whether caution and routing data is displayed or not. <ul style="list-style-type: none"> • OFF — caution and routing data is NOT displayed. • ON — caution and routing data is displayed. | <ul style="list-style-type: none"> • OFF • ON (default) |
| Marine Features | When this menu item is set to ON, the following water-based cartographic features are displayed: <ul style="list-style-type: none"> • Cables. • Nature of seabed points. • Tide stations. • Current stations. • Port information. | <ul style="list-style-type: none"> • OFF • ON (default) |
| Land Features | When this menu item is set to ON, land-based cartographic features are displayed. | <ul style="list-style-type: none"> • OFF • ON (default) |
| Deep Water Color | Determines the color used to shade areas of deep water. (The depth used to determine areas of deep water is specified by the Safety Contour setting) | <ul style="list-style-type: none"> • White (default) • Blue |
| Business Services | When this menu item is set to ON, symbols indicating the location of a business will be shown. | <ul style="list-style-type: none"> • OFF • ON (default) |
| Panoramic Photos | Determines whether panoramic photos are available for landmarks such as ports and marinas. | <ul style="list-style-type: none"> • OFF (default) • ON |
| Roads | Determines whether major coastal roads are displayed on the chart: <ul style="list-style-type: none"> • OFF — coastal roads are NOT displayed. • ON — coastal roads are displayed. | <ul style="list-style-type: none"> • OFF • ON (default) |

| Menu item | Description | Options |
|-----------------------------|--|---|
| Additional Wrecks | Determines whether extended information for new wrecks is displayed. | <ul style="list-style-type: none"> • OFF • ON (default) |
| Aerial Photo Overlay | Determines the areas of the chart covered by the aerial photo overlay feature. | <ul style="list-style-type: none"> • On Land (default) • On Land and Sea • On Land and Shallow |
| Colored Seabed Areas | Provides greater definition of the seabed. This applies only to limited areas where the extra detail is available. | <ul style="list-style-type: none"> • OFF (default) • ON |

Chapter 7: Using autopilot control

Chapter contents

- [7.1 Enabling the autopilot control function on page 104](#)
- [7.2 Disengaging the autopilot in an emergency on page 104](#)
- [7.3 Autopilot control on page 105](#)
- [7.4 Autopilot control options on page 106](#)
- [7.5 Autopilot dialog box on page 106](#)
- [7.6 Autopilot status symbols on page 107](#)
- [7.7 Autopilot alarms on page 108](#)

7.1 Enabling the autopilot control function

1. Press the **MENU** button.
2. Select **System Setup**.
3. Select **System Integration**.
4. Use the **Autopilot Control** menu item to select the Enabled option.

7.2 Disengaging the autopilot in an emergency

While following a route using the autopilot:

1. Press and release the **POWER** button.
2. Press the **PILOT STANDBY** softkey.

The autopilot is disengaged, and put into standby mode.

7.3 Autopilot control

You can use your multifunction display to control your autopilot.

Note: For information on connecting an autopilot to your multifunction display, refer to the documentation that accompanies the autopilot.

With the Autopilot Control function enabled, you can use your multifunction display to:

- Engage the autopilot and instruct it to follow a route, or a waypoint.
- Disengage the autopilot.
- Silence the waypoint arrival alarm.

Pilot Control dialog

The autopilot control functions on your multifunction display are centered around the Pilot Control dialog. This dialog is displayed in the following situations:

- When you press the **GOTO** or **FOLLOW ROUTE** softkey in the chart application.
- When you are following a route or going to a waypoint or cursor position, and place the cursor over an active route or waypoint on the chart, and press the **STOP GOTO**, **STOP FOLLOW**, or **ADVANCE WAYPOINT** softkey.
- When you arrive at a target waypoint.

Autopilot touchscreen restrictions

For safety reasons, softkeys that initiate key pilot actions cannot be selected using the touchscreen.

The affected softkeys are:

- **ENGAGE PILOT — TRACK**
- **AUTO**

You must use the physical keys to select these softkeys.

Engaging the autopilot

In the chart application:

1. Select the **NAVIGATION** softkey.
2. Select the **GOTO CURSOR**, **FOLLOW ROUTE OPTIONS**, or **GOTO WAYPOINT OPTIONS** softkey, as appropriate.
3. Select the **ENGAGE PILOT — TRACK** softkey.
The Pilot Control dialog is displayed.
4. Select the appropriate softkey to engage the autopilot.

Engaging the autopilot using hotpotting

In the chart application:

1. Position the cursor over a waypoint, or a waypoint in a route.
The softkeys change to provide further options.
2. Select the **GOTO WAYPOINT** softkey.
3. Select the **ENGAGE PILOT — TRACK** softkey.

Disengaging the autopilot

In the chart application with the autopilot engaged:

1. Press the **STOP GOTO** or **STOP FOLLOW** softkeys:
The Pilot Control dialog is displayed.
2. Press the **STANDBY** softkey.
The autopilot is disengaged, and put in standby mode.

7.4 Autopilot control options

Your multifunction display enables you to navigate to target waypoints using the autopilot control options.

When you arrive at a waypoint, the Pilot Control dialog is displayed, providing the following options:

| Option | Description |
|----------------------|--|
| ENGAGE PILOT — TRACK | Engages the autopilot and continues to the next waypoint in the route. This option is not available if you have reached the last waypoint in the route. |
| CLEAR ALARM | Silences the waypoint arrival alarm. Continues on the current heading. |
| STANDBY | Cancels the waypoint arrival alarm and disengages the autopilot. |
| AUTO | Cancels the waypoint arrival alarm and engages the autopilot in auto mode. If you just arrived at the last waypoint in the route, the autopilot continues on the current locked heading. |

7.5 Autopilot dialog box

The autopilot dialog box provides important information when navigating using the integrated autopilot controls.

The following information is displayed:

- Autopilot information, including status and heading.
- Waypoint information, including name, bearing and distance.
- Turn angle. The turn angle is only available for SPX autopilots connected using SeaTalk^{ng}. This indicates the direction and severity of turns to be made under autopilot.

Example autopilot dialog

| Pilot Control | | | |
|---|--------------|-------------------------|---|
| Pilot Information: | | Active Waypoint: | |
| Status: | TRACK | Name: | GOTO CURSOR |
| HDG: | 214°T | BTW: | 214°T |
| | | DTW: | 0.326nm |
| AUTO : To steer on current heading STANDBY : For manual steering | | | |
| OK or CANCEL : To remove dialog | | | |
| | | |  |
| | | | Turn 12° |









Waypoint arrival



When arriving at a waypoint, the dialog title bar turns red to indicate the waypoint arrival alarm.

- Select **ACKNOWLEDGE** to silence the alarm.
- Select **STANDBY** for manual steering.

7.6 Autopilot status symbols

The autopilot status is indicated in the databar.

| Symbol | Description |
|--|-------------------------------|
|  | Autopilot is in Standby mode. |
|  | Autopilot is in Track mode. |
|  | Autopilot is in Auto mode. |
|  | No autopilot detected. |
|  | Autopilot alarm active. |
|  | Dodge mode is active. |
|  | Fish mode is active. |
|  | Autopilot calibration. |

| Symbol | Description |
|--|---------------------------|
|  | Power steering active. |
|  | Wind Vane mode is active. |

7.7 Autopilot alarms

The autopilot functions provide alarms to alert you to situations that require action.

Your multifunction display shows autopilot alarms, regardless of whether there is active navigation on the system. If pilot integration is enabled, and an alarm is raised by the autopilot, the multifunction display provides an audible alarm sound (providing that the alarm has not already been silenced). The Pilot Control screen is displayed, indicating a new alarm. Additionally, the pilot transducer icon is displayed in red, and remains red until the alarm is cleared.

Silencing autopilot alarms

1. Press the **CLEAR ALARM** softkey.

The alarm is silenced and the autopilot remains engaged in auto mode, continuing on the current heading.

Silencing autopilot alarms and disengaging autopilot

1. Press the **STANDBY** softkey.

The alarm is silenced, and the autopilot is disengaged and put in standby mode.

Chapter 8: Using alarms and MOB functions

Chapter contents

- [8.1 Using Man Overboard \(MOB\) functions on page 110](#)
- [8.2 Alarms on page 111](#)

8.1 Using Man Overboard (MOB) functions

Man overboard

If you lose a person or object overboard, you can use the Man Overboard (MOB) function to mark the position.

The MOB function is available at all times, regardless of which application is running.

When MOB is activated, an alert message appears on-screen, and an emergency waypoint is created. A bearing to the waypoint is also provided. The alert and emergency waypoint also appear on any networked displays at the same time.

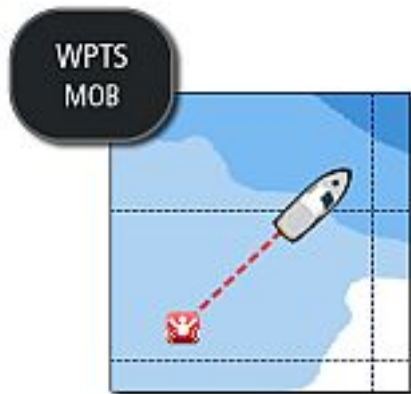

Activating the man overboard function

1. Press and hold the WPTS/MOB button for 3 seconds.

The normal chart application is reset to the same settings that it had before the MOB alarm was raised.

Note: To obtain a MOB position, your multifunction display must have a GPS position fix.

Cancelling a MOB alarm

1. Press and hold the **WPTS/MOB** button for four seconds.
Once the MOB alarm is cleared:
 - the chart application motion mode is reset.
 - the databar mode is reset.
 - GOTO and route functions are restored.

MOB chart application

If a MOB is raised while the chart application or the home screen is displayed, a special MOB chart application is started to help you locate the source of the distress signal.

The special MOB chart application is displayed on your multifunction display and any other networked multifunction display(s). The special MOB chart application has the following features and settings:

- A MOB symbol is placed at the position of the vessel when the MOB button was pressed.
- The chart is set to Auto Range Motion Mode, and the chart scale is set to the lowest setting that maintains the vessel and MOB waypoint on-screen at the same time.
- If the vessel moves away from the MOB position, the system draws a dotted line joining the MOB position with the vessel position.
- GOTO and Route functions are disabled.
- Chart detail is set to low.
- All other chart controls, including overlays, are set to their default settings.

- MOB position data is displayed in the databar along the top of the screen.
- Any chart settings that you make to the special MOB chart application will not be saved.

When you cancel the MOB alarm, the special MOB chart application is closed.

The normal chart application is reset to the same settings that it had before the MOB alarm was raised.

Responding to a MOB alarm on the home screen

With the home screen and a MOB alert displayed:

1. Select the **ACKNOWLEDGE** softkey.
The alarm is silenced and a special MOB chart application is displayed.

8.2 Alarms

Alarms alert you to a situation or hazard requiring your attention.

You can set up alarms to alert you to certain conditions, such as collision warnings and temperature limits.

Alarms are raised by system functions, and also external equipment connected to your multifunction display.

When an alarm sounds, a message dialog is displayed on your multifunction display, and any networked displays. The dialog explains the reason for the alarm.

You can configure the behaviour of the following system and application alarms using the **Alarms Setup Menu**:

- System alarms.
- Navigation alarms.
- Radar alarms.
- Fishfinder alarms.
- AIS alarms.

Cancelling alarms

1. Press the **ACKNOWLEDGE** softkey.

Accessing the alarms setup menu

1. Press the **MENU** button.
2. Select **Alarm Setup**.
The Alarm Setup Menu is displayed.
3. Select the appropriate alarm category.

System alarm setup

| Menu item | Description | Options |
|----------------------------|--|--|
| Anchor Alarm | When set to ON, the anchor alarm is triggered when your vessel drifts from your anchor position by more than the distance you specify for the Anchor Alarm Radius setting (see below). | <ul style="list-style-type: none"> • OFF (default) • ON |
| Anchor Alarm Radius | Specifies the distance your vessel must drift away from its anchor position before the anchor alarm is triggered. The units used for this setting are based on the units you specify for distance in the Units Setup Menu. | 0.01 to 9.99 nm (or equivalent units) |
| Timer | When set to ON, counts down the time period you specify for the Timer Period setting (see below), and triggers an alarm when zero is reached. | <ul style="list-style-type: none"> • OFF (default) • ON |
| Timer Period | Specifies the countdown period for the timer. When the countdown reaches zero, an alarm is triggered. | <ul style="list-style-type: none"> • 00h00m (default) • 00h01m to 99h59m |

| Menu item | Description | Options |
|--------------------------------|---|--|
| Alarm Clock | When set to ON, an alarm is triggered at the time you specify for the Alarm Clock Time setting (see below). | <ul style="list-style-type: none"> • OFF (default) • ON |
| Alarm Clock Time | An alarm will sound at the time you specify for this setting. | <ul style="list-style-type: none"> • 00:00 (default) • 00.01 to 24:00 hrs |
| Temperature Alarm | When set to ON, triggers an alarm when the temperature you specify for the Lower Temperature Limit or Upper Temperature Limit setting (see below) is reached. | <ul style="list-style-type: none"> • OFF (default) • ON |
| Lower Temperature Limit | Specifies the lower limit of the temperature range that will trigger the Temperature Alarm. | <ul style="list-style-type: none"> • 60 degrees fahrenheit (default) • -09.9 to +99.7 degrees fahrenheit |
| Upper Temperature Limit | Specifies the upper limit of the temperature range that will trigger the Temperature Alarm. | <ul style="list-style-type: none"> • 75 degrees fahrenheit (default) • -09.7 to 99.9 degrees fahrenheit |

Navigation alarms setup

| Menu item | Description | Options |
|-----------------------------|--|---|
| Arrival Alarm Radius | When you arrive at a waypoint, an alarm is triggered. This setting allows you to specify the distance from the target waypoint at which the alarm is triggered. The units used for this setting are based on the units you specify for distance in the Units Setup Menu. | 0.01 to 9.99 nm (or equivalent units) |
| Offtrack Alarm | When set to ON, an alarm is triggered when your vessel steers off-track a greater distance than the value you specify for the Offtrack Alarm XTE setting (see below). | <ul style="list-style-type: none"> • OFF (default) • ON |
| Offtrack Alarm XTE | Specifies the distance for the Offtrack Alarm setting (see above). | 0.01 to 9.99 nm (or equivalent units) |

| Menu item | Description | Options |
|------------------------|--|---|
| Collision Alarm | <p>When Collision Alarm is set to ON, an alarm is triggered when charted objects appear in the alarm zone's vicinity. The zone is set up using the Setup Alarm Zone setting (see below). You must also set the Display Alarm Zone setting (see below) to ON in order to view the zone in the chart application.</p> <div style="border: 1px solid black; padding: 5px;"> <p>Note: The accurate operation of the collision alarm is dependent on you supplying suitable values for the Boat Details setting (MENU > System Setup > Boat Details), which must be appropriate for safe navigation. The values you specify must also take into account the position of the GPS antenna on your vessel, as the collision alarm uses data from the GPS antenna.</p> </div> | <ul style="list-style-type: none"> • OFF (default) • ON |

| Menu item | Description | Options |
|---------------------------|--|---|
| Setup Alarm Zone | Enables you to specify the zone for the Collision Alarm setting (see above). When you select the Setup Alarm Zone menu item, you can use the ADJUST RANGE and ADJUST ANGLE softkeys to define the zone. If you access this menu item while using the chart application, a visual indication of the alarm zone is displayed when you use the softkeys to define the zone. | |
| Display Alarm Zone | When set to ON, the zone for the Collision Alarm (see above) is displayed in the chart application. | <ul style="list-style-type: none"> • OFF (default) • ON |

Collision alarm

You can set up a collision alarm zone in front of your vessel to alert you to charted objects above a specified depth, or below a specified height.

If the Collision Alarm is set to ON, an alarm is triggered when charted objects appear in the zone's vicinity. If an object exits the collision alarm zone and then re-enters it, a subsequent alarm is raised.

You can specify the size of the collision alarm zone, which consists of 2 sectors:

- the range in front of your vessel, which can be adjusted between 0.05 and 2 nautical miles.
- the bearing from your vessel (width of the zone), which can be adjusted between 0 and 90.

The collision alarm zone maintains its relative position to the vessel as its position and heading changes.

The following charted objects trigger an alarm when they enter the collision alarm zone:

- **Land:**
 - Land.
 - Rocks.
 - Offshore structures.
 - Shoreline constructions.
- **Depths:**
 - Depths.
- **Entry-restricted areas:**
 - Anchorage areas.
 - Cables.
 - Fish areas.
 - Military areas.
 - Offshore structures.
 - Pipeline.
 - Waste areas.
- **Submerged obstructions:**
 - Obstructions.
 - Wrecks.
- **Overhead obstructions:**
 - Cables.

- Cultural features.

Note: A dotted or dashed collision alarm zone indicates that there is insufficient cartographic information for the collision alarm to function correctly. In these situations, the collision alarm will NOT function.

Setting up the anti-collision alarm zone

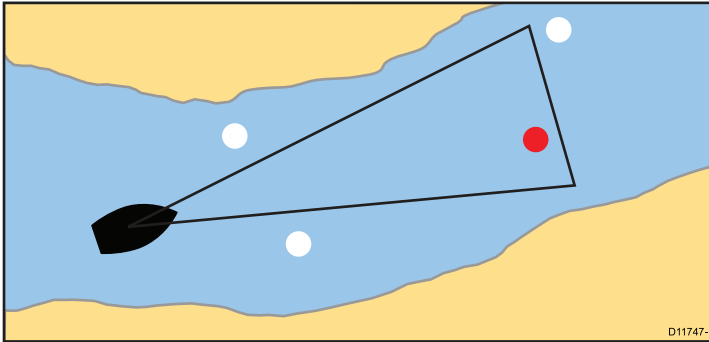

1. Press the **MENU** button.
2. Select **Alarm Setup**.
3. Select **Navigation Alarms Setup**.
4. Select **Setup Alarm Zone**.
If you are using the chart application when you access this menu item, a visual indication of the alarm zone is displayed in front of the vessel icon.
5. To specify the range in front of your vessel that will be monitored, press the **ADJUST RANGE** softkey and use the rotary control to adjust the value.
6. To specify the bearing from your vessel (width of the zone), press the **ADJUST ANGLE** softkey and use the rotary control to adjust the value.

7. Press the **OK** button to save the changes, or the **CANCEL** button to revert to the previously saved settings.

Radar alarms setup

| Menu item | Description | Options |
|--------------------------------|--|-----------|
| Guard Zones Sensitivity | The guard zone feature in the radar application triggers an alarm when a target is within a specified zone. You can adjust the sensitivity of the alarm. Ensure that the sensitivity is not set too low, or targets may be missed and the alarm will not be triggered. | 0 to 100% |

Fishfinder alarms setup

This section describes the settings you can change using the fishfinder alarms setup menu.

| Menu Item | Description | Options |
|------------------------|---|---------|
| Fish Alarm | Alarm which responds to quantities of fishfinder targets | OFF, ON |
| Fish Alarm Sensitivity | If the Fish Alarm is set to ON, an alarm is triggered when the fish return strength reaches the sensitivity that you specify. | 1 to 10 |

| Menu Item | Description | Options |
|---------------------------|---|-------------------------------------|
| Fish Alarm Depth Limits | If the Fish Alarm and this alarm is set to ON, an alarm is triggered (2 beeps) if any target meets the sensitivity level and is within the Shallow Fish Limit and Deep Fish Limit that you specify. | OFF, ON |
| Shallow Fish Limit | Specifies the lower value for the Fish Alarm Depth Limit. | 0002 ft to 1000 ft |
| Deep Fish Limit | Specifies the upper value for the Fish Alarm Depth Limit | 0002 ft to 1000 ft |
| Shallow Depth Alarm | Switches the shallow depth alarm on or off. If a DSM is not connected, this cannot be set. | OFF, ON |
| Shallow Depth Alarm Value | If the Shallow Depth Alarm is set to ON, an alarm is triggered if the depth drops below the value you specify. | 0002 ft to maximum transducer range |

| Menu Item | Description | Options |
|------------------------|--|-------------------------------------|
| Deep Depth Alarm | Deep Depth Alarm Switches the deep depth alarm on or off. If a DSM is not connected, this cannot be set. | OFF, ON |
| Deep Depth Alarm Value | If the Deep Depth Alarm is set to ON, an alarm is triggered if the depth exceeds the value that you specify. | 0002 ft to maximum transducer range |

AIS alarms setup

| Menu item | Description | Options |
|--------------------------------|--|---|
| Dangerous Targets Alarm | When set to ON, the alarm for dangerous AIS targets is enabled. | <ul style="list-style-type: none"> • ON (default) • OFF |
| AIS Alarm List | Displays the AIS Alarms List, which details the identity, description, time, and acknowledgement status of alarm messages received from an AIS receiver. | |

Chapter 9: Using radar

Chapter contents

- [9.1 Radar overview on page 118](#)
- [9.2 Digital radar scan speed on page 118](#)
- [9.3 Radar scanner status symbols on page 119](#)
- [9.4 Radar range and image quality on page 120](#)
- [9.5 Radar display overview on page 123](#)
- [9.6 Dual range radar operation on page 125](#)
- [9.7 Radar mode and orientation on page 126](#)
- [9.8 Radar tuning: HD and SuperHD digital scanners on page 129](#)
- [9.9 Radar tuning: non-HD digital radomes on page 134](#)
- [9.10 Using radar to measure distances, ranges, and bearings on page 138](#)
- [9.11 Using radar to track targets and avoid collisions on page 142](#)
- [9.12 Radar setup menu options on page 146](#)

9.1 Radar overview

Radar is used to provide information that can help you to track targets and measure distances and bearings.

Radio Detection And Ranging (RADAR) is used at sea to detect the presence of objects (known as 'targets') at a distance, and if they are moving, detect their speed.

Radar works by transmitting radio pulses, then detecting reflections of these pulses (echoes) from objects in the area and displaying the reflections as targets on your display.

Until you are familiar with interpreting the radar display, every opportunity should be taken to compare the radar screen patterns with visual targets, such as other boats, buoys and coastal structures. You should practise harbor and coastal navigation during daylight hours and in clear weather conditions.

HD and SuperHD digital radar

Your multifunction display can be used with digital radar scanners.

HD and SuperHD Digital radar scanners provide a range of advantages, making it easier to discern objects around your vessel.

HD and SuperHD Digital radar scanners provide:

- Improved target detection.
- Full-color image.
- Dual Range operation.
- SuperHD option. This effectively increases the transmitter power by a factor of at least 2, and reduces the beamwidth by a similar amount.

Note: You must connect a SuperHD radar scanner in order to use the SuperHD option.

9.2 Digital radar scan speed

Certain digital radar scanners support multiple scan speeds.

Radar scan speed is set up using the Digital Scanner Setup Menu, accessible from the Radar Setup menu. When the system detects a scanner that is capable of operating at both 24 RPM and 48 RPM, 2 options are provided for scanner speed:

- 24 RPM
- Auto

If you have a digital radar scanner that only operates at 24 RPM, the scanner speed option is disabled. If the scanner speed option is enabled, you must select the Auto option if you want to use the higher scan speeds. This option automatically switches between the 24 RPM and 48 RPM scan speeds as appropriate.

Selecting radar scanner speed

The speed option requires a 48 RPM compatible SuperHD digital radar scanner.





Select your radar scanner speed from within the radar application.

1. Press the **MENU** button.
2. Select Radar Setup > Scanner Speed menu options.
3. Select the Scanner Speed menu item and the appropriate speed setting:
 - Auto
 - 24 RPM

The Auto option automatically selects the appropriate speed for your radar range. 48 RPM is used at radar ranges of up to 3 nm. It provides an increased refresh rate, which is useful at high speed or in areas where you have large numbers of radar targets. At radar ranges of greater than 3 nm the display switches the radar speed to 24 RPM.

9.3 Radar scanner status symbols

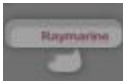
The radar scanner power mode status is indicated in the databar.

| Symbol | Radar power mode | Description |
|--|------------------|--|
|  | Transmit (TX) | Rotating icon, signifying that the scanner is on and transmitting. When SCANNER is set to ON, select this mode to activate the scanner. This is the usual mode of operation. |
|  | Standby (STBY) | Static icon, indicating that the scanner is on but not transmitting, and the antenna is not rotating. The scanner does not transmit and the radar data is removed from the screen. This is a power-save mode used when the radar is not needed for short time periods. When you return to transmit mode, the magnetron does not need to warm up again. This is the default mode. |
|  | Off | Scanner powered off when radar not required, but display is in use for other applications, such as the chart. When selected, the system counts down. During this time you cannot re-power the scanner. |
|  | Timed Transmit | Scanner switches between on/transmitting, and standby mode. Scanner goes into power save mode when constant use of radar is not required. |

Powering the radar scanner on and off

In the radar application:

1. Press the **POWER** button on your multifunction display.
2. Using the relevant softkeys, select the operating mode for the radar scanner.

9.4 Radar range and image quality

Maximum radar range

The usable range of the radar is limited by factors such as the height of the scanner, and height of the target.

Maximum radar range is essentially line-of-sight, so is limited by the height of the scanner and the height of the target as illustrated below:

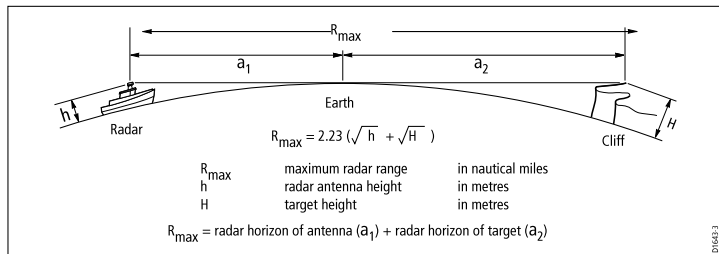

The table below shows typical maximum radar ranges for various radar antenna heights and target heights. Remember that although the radar horizon is greater than the optical horizon, the radar can only detect targets if a large enough target is above the radar horizon.

| Antenna height (meters) | Target height (meters) | Maximum range (Nautical miles) |
|-------------------------|------------------------|--------------------------------|
| 3 | 3 | 7.7 |
| 3 | 10 | 10.9 |
| 5 | 3 | 8.8 |
| 5 | 10 | 12 |

Radar image quality

A number of factors can affect the quality of a radar image, including echoes, sea clutter, and other interference.

Not all radar echoes are produced by valid targets. Spurious echoes may be caused by:

- Side lobes.
- Indirect echoes.
- Multiple echoes.
- Blind sectors.
- Sea, rain, or snow clutter.
- Interference.

Through observation, practice, and experience, you can generally detect these conditions very quickly and use the radar controls to minimize them.

Side Lobes

Side lobe patterns are produced by small amounts of energy from the transmitted pulses that are radiated outside the narrow main beam. The effects of side lobes are most noticeable with targets at short ranges (normally below 3 nm), and in particular with larger objects. Side lobe echoes form either arcs on the radar screen similar to range rings, or a series of echoes forming a broken arc.

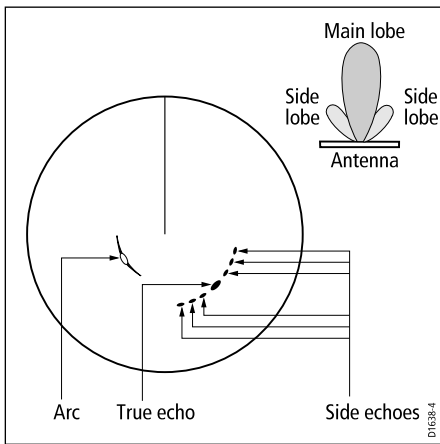

Multiple Echoes

Multiple echoes are not very common but can occur if there is a large target with a wide vertical surface at a comparatively short range. The transmitted signal will be reflected back and forth between the target and your own ship, resulting in multiple echoes, displayed beyond the range of the true target echo, but on the same bearing.

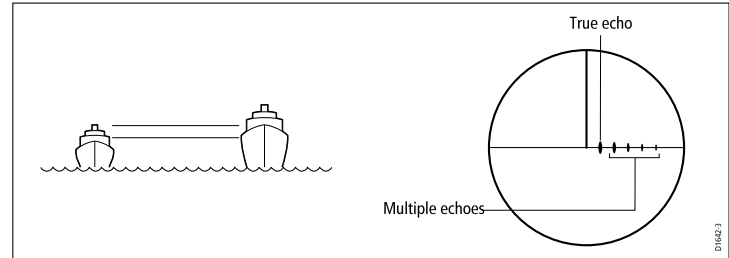

Indirect Echoes

There are several types of indirect echoes or ghost images. These sometimes have the appearance of true echoes, but in general they are intermittent and poorly defined.

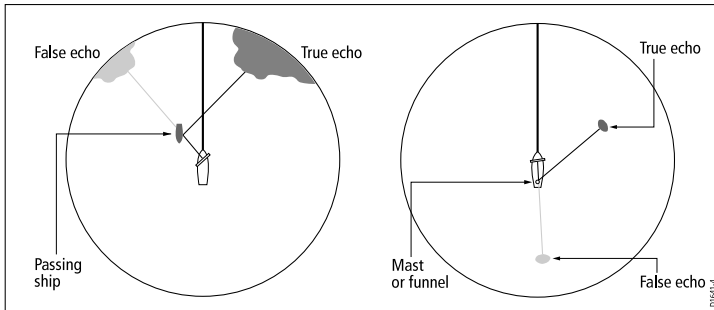

Blind Sectors

Obstructions such as funnels and masts near the radar antenna may obstruct the radar beam and cause radar shadows or 'blind sectors'. If the obstruction is relatively narrow, there will be a reduction of the beam intensity, though not necessarily a complete cut-off. However, for wider obstructions there may be a total loss of signal in the shadow area. There may also be multiple echoes which extend behind the obstruction. Blind sector effects can normally be minimized by careful selection of the scanner site prior to installation.

Sea Clutter

Radar returns from waves around the vessel can clutter the centre of the radar picture, making it difficult to detect real targets. Such 'sea clutter' usually appears as multiple echoes on the display at short range scales, and the echoes are not repetitive or consistent in position. With high winds and extreme conditions, echoes from sea clutter may cause dense background clutter in the shape of an almost solid disc.

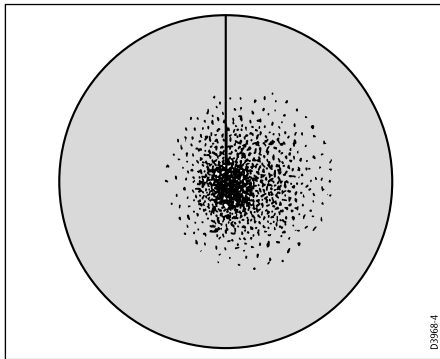

D3988-4

Rain or Snow Clutter

The radar can see echoes from rain or snow. Returns from storm areas and rain squalls consist of countless small echoes that continuously change size, intensity and position. These returns sometimes appear as large hazy areas, depending on the intensity of the rainfall or snow in the storm cell.

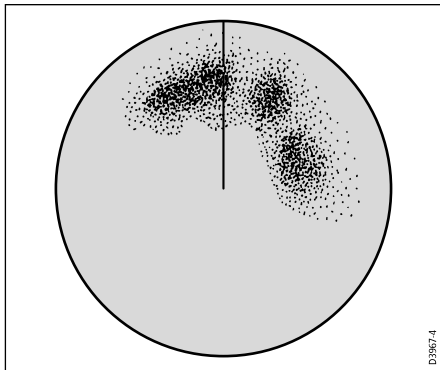

D3957-4

Interference

When two or more radar-equipped vessels are operating within range of each other mutual radar interference can occur. This usually appears as a spiral of small dots from the display centre. This type of interference is most noticeable at long ranges.

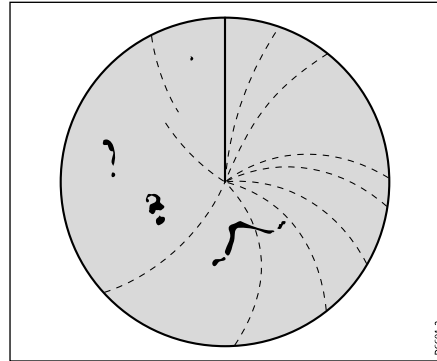

D6601-2

9.5 Radar display overview

With your radar scanner connected and the radar in transmit mode, the radar picture provides a map-like representation of the area in which the radar is operating.

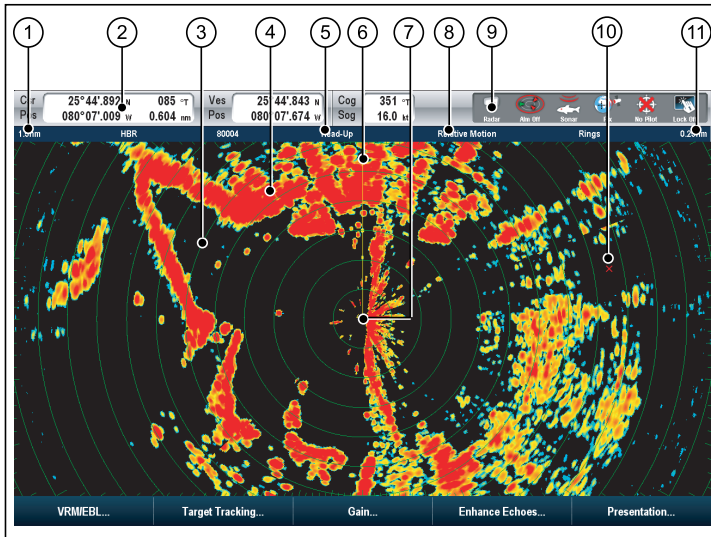

| Item | Description |
|------|-----------------------------|
| 1 | Range |
| 2 | Databar |
| 3 | Range ring |
| 4 | Land mass |
| 5 | Orientation |
| 6 | Ship's Heading Marker (SHM) |

| Item | Description |
|------|----------------------|
| 7 | Ship's position |
| 8 | Motion Mode |
| 9 | Radar scanner status |
| 10 | Waypoint |
| 11 | Range ring spacing |

Typically, your vessel's position is at the center of the display, and its dead ahead bearing is indicated by a vertical heading line, known as the Ship's Heading Marker (SHM).

On-screen targets may be large, small, bright or faint, depending on the size of the object, its orientation and surface. If using a non-HD digital radome scanner, strongest target returns are displayed in yellow with weaker returns in 2 shades of blue. If using an HD or SuperHD digital radar scanner, stronger target returns show as different colors from a range of 256 colors, providing better clarity. Be aware that the size of a target on screen is dependent on many factors and may not necessarily be proportional to its physical size. Nearby objects may appear to be the same size as distant larger objects.

With experience, the approximate size of different objects can be determined by the relative size and brightness of the echoes.

You should bear in mind that the size of each on-screen target is affected by:

- The physical size of the reflecting object.
- The material from which the object is made. Metallic surfaces reflect signals better than non-metallic surfaces.
- Vertical objects such as cliffs reflect signals better than sloping objects such as sandbanks.
- High coastlines and mountainous coastal regions can be observed at longer radar ranges. Therefore, the first sight of land may be a

mountain several miles inland from the coastline. Although the coastline may be much nearer, it may not appear on the radar until the vessel is closer to shore.

- Some targets, such as buoys and small boats, can be difficult to discern, because they do not present a consistent reflecting surface as they bob and toss about in the waves. Consequently these echoes tend to fade and brighten, and at times disappear momentarily.
- Buoys and small boats often resemble each other, but boats can often be distinguished by their motion.

Note: A GPS receiver and a fast heading sensor are required for MARPA operation, and to maximize radar/chart overlay performance.

4. Select the **EDIT NAME** softkey.
The on-screen keyboard is displayed.
5. Use the on-screen keyboard to enter a name for the scanner, then select **SAVE**.

Assigning a scanner to a radar display

If your system has 2 radar scanners you can select which one to use for the current radar view.

In the radar application:

1. Press the **MENU** button.
2. Select **Radar Setup**.
3. Select the **Select Scanner** menu item.
A list of connected scanners is displayed.
4. Select the scanner you want to use with the current radar application.

Naming a radar scanner

You can name radar scanners for easy identification.

In the radar application:

1. Press the **MENU** button.
2. Select **Radar Setup**.
3. Highlight the **Select Scanner** menu item.

9.6 Dual range radar operation

The Dual Range radar function enables you to view 2 ranges at the same time in separate windows. The function is only available with HD and SuperHD radar scanners.

Using your multifunction display and an HD or SuperHD digital radar scanner, you can view either a short or a long range image in separate radar windows.

The default setting is Long, which provides a standard scanner range.

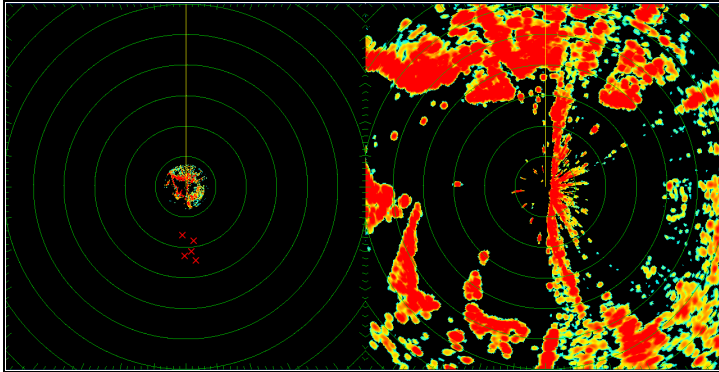

Limitations

- Dual Range operation is not available if MARPA targets are active.
- You cannot acquire MARPA targets if Dual Range is enabled.
- Chart-sync and chart overlay are temporarily disabled when Dual Range is enabled.

Dual range radar compatibility

The range covered by the short Dual Range option depends on the radar scanner you are using, and the software version it is using.

| Scanner | Dual range mode | Range covered by software versions 1.xx to 2.xx | Range covered by software versions 3.xx onwards |
|----------------------------------|-----------------|---|---|
| 4 Kw HD Digital Open Array | Long | 1/8 nm to 72 nm | 1/8 nm to 72 nm |
| | Short | 1/8 nm to 3 nm | 1/8 nm to 72 nm |
| 4 Kw SuperHD Digital Open Array | Long | 1/8 nm to 72 nm | 1/8 nm to 72 nm |
| | Short | 1/8 nm to 3 nm | 1/8 nm to 72 nm |
| 12 Kw HD Digital Open Array | Long | 1/8 nm to 72 nm | 1/8 nm to 72 nm |
| | Short | 1/8 nm to 3 nm | 1/8 nm to 72 nm |
| 12 Kw SuperHD Digital Open Array | Long | 1/8 nm to 72 nm | 1/8 nm to 72 nm |
| | Short | 1/8 nm to 3 nm | 1/8 nm to 72 nm |
| HD Digital Radome | Long | 1/8 nm to 72 nm | 1/8 nm to 72 nm |
| | Short | 1/8 nm to 72 nm | 1/8 nm to 72 nm |

Using Dual Range with SuperHD scanners

Dual range radar operation with SuperHD scanners.

When using the short Dual Range option, a SuperHD scanner operates in HD mode only. When using the long Dual Range option, a SuperHD radar operates in SuperHD mode.

| Scanner | Dual Range mode | Operating mode |
|----------------------------------|-----------------|----------------|
| 4 Kw SuperHD Digital Open Array | Long | SuperHD |
| | Short | HD |
| 12 Kw SuperHD Digital Open Array | Long | SuperHD |
| | Short | HD |

Enabling Dual Range radar operation

In the radar application, with an HD or SuperHD radar scanner connected to your multifunction display:

1. Select the **PRESENTATION** softkey.
2. Select the ON option for the **DUAL RANGE** softkey.

Selecting long or short range radar operation

In the radar application:

1. Select the **PRESENTATION** softkey.
2. Use the **DUAL RANGE** softkey to select the LONG or SHORT option, as appropriate.

9.7 Radar mode and orientation

Radar orientation modes

The radar can operate in a number of orientation modes to suit different types of navigation.

The orientation of the radar refers to the relationship between the radar and the direction that you are travelling in. There are three orientation modes to choose from:

- Head up.
- North up.
- Course up.

These orientation modes are used in conjunction with motion mode to control how your boat and radar relate to one another and how they are displayed on screen. Any changes that you make to the orientation of the radar are retained when you switch off your multifunction display.

Head Up (H-UP)

This is the default mode for the radar application.

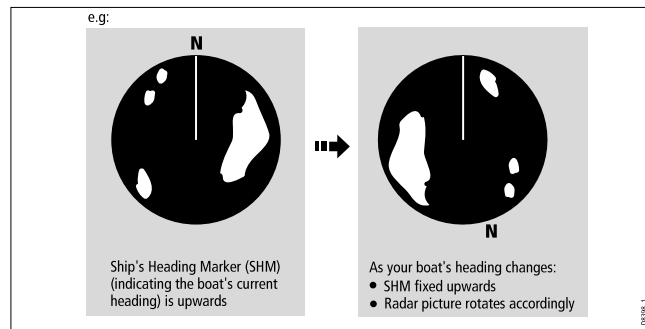

North Up (N-UP)

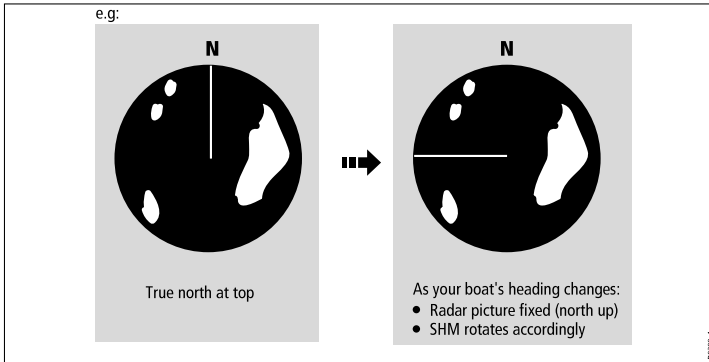

Course Up (C-UP)

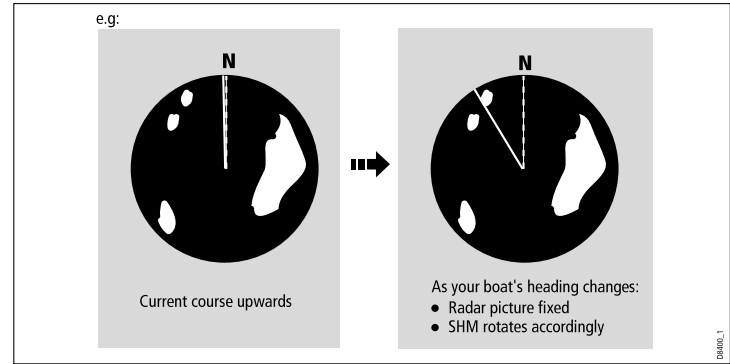

Note: If heading data becomes unavailable whilst in this mode, a warning message will be shown, the status bar indicates North-Up in brackets and the radar uses 0° heading in relative motion. When heading data becomes available once more, North-Up mode is reinstated.

Note: It is not possible to select Head Up mode when the motion mode is set to True.

If you select a new course, the picture will reset to display the new course upwards.

The reference used for Course-Up depends upon the information available at a given time. The system always prioritizes this information in the following order:

1. Bearing from origin to destination, that is, intended course.
2. Locked heading from an Autopilot.
3. Bearing to waypoint.
4. Instantaneous heading.

Note: If heading data becomes unavailable whilst in this mode, a warning message will be shown, the status bar indicates the Course Up in brackets and the radar uses 0° heading in relative motion. When heading data becomes available once more, Course-Up mode is reinstated.

Selecting the radar orientation mode

In the radar application:

1. Press the **PRESENTATION** softkey.

2. Press the **RADAR MODE AND ORIENTATION** softkey.
3. Using the **ORIENTATION** softkey, select the required orientation mode.

Changing the radar vessel offset

In the radar application:

1. Press the **PRESENTATION** softkey.
2. Press the **RADAR MODE AND ORIENTATION** softkey.
3. Using the **VESSEL OFFSET** softkey, select the required vessel offset.

Radar motion modes overview

The motion mode controls the relationship between the radar and your boat. There are two modes:

- Relative motion.
- True motion.

The selected motion mode is displayed in the status bar. The default setting is relative motion with zero offset.

Relative Motion (RM) with optional Vessel Offset

When the motion mode is set to Relative, the position of your boat is fixed on the screen and all the targets move relative to the boat. You can specify whether the boat is fixed in the centre of the window (0 offset) or offset by 1/3 or 2/3 to increase the view ahead, as shown below:

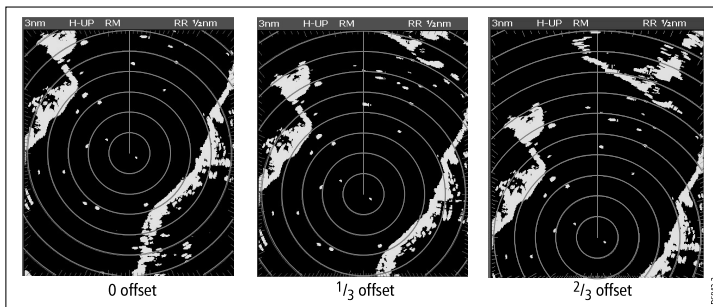

The default motion mode is “Relative”, with zero offset.

True Motion (TM)

When the motion mode is set to True, fixed radar targets maintain a constant position and moving vessels (including your boat) travel in true perspective to each other and to fixed landmasses on the screen. As the boat’s position approaches the edge of the screen, the radar picture is automatically reset to reveal the area ahead.

Note: If heading and position data become unavailable when True motion is selected, a warning message will be shown, the mode will revert to relative motion and be noted in the status bar in brackets, for example, (TM).

Note: It is not possible to select True Motion when the orientation is set to Head Up.

Selecting the radar motion mode

In the radar application:

1. Press the **PRESENTATION** softkey.
2. Press the **RADAR MODE AND ORIENTATION** softkey.
3. Using the **MOTION MODE** softkey, select the relevant mode.

9.8 Radar tuning: HD and SuperHD digital scanners

You can use the gain presets and other functions to improve the quality of the radar picture.

The following settings apply to HD radomes and HD and SuperHD open array digital scanners:

| Tuning method | Related options | Description |
|--|---|---|
| <p>Gain presets</p> <ul style="list-style-type: none"> • Buoy — a special mode that enhances the detection of small objects like mooring buoys. It is useful at ranges up to 0.75 nm. • Harbor — this is the default mode. This setting takes account of land clutter so that smaller targets, like navigation buoys, are not lost. • Coastal — accounts for the slightly higher levels of sea clutter you might encounter out of harbor and adjusts the radar display accordingly. • Offshore — automatically adjusts for high levels of sea clutter. • Bird Mode — a special mode that helps you to identify flocks of birds, useful when identifying suitable fishing locations, for example. | <p>For each preset, the following options are available:</p> <ul style="list-style-type: none"> • Gain — enables you to use a preset in automatic mode, or to adjust its gain manually between 0 and 100%. • Color Gain— adjusts the intensity (color) of displayed targets, but does not significantly affect the number of targets displayed. Increasing the color gain causes more targets to be displayed in the same color, which may help you to determine whether an object is an actual target, or just background noise. Reducing the color gain may provide better target detail and detection. • Rain — the radar scanner detects echoes from rain or snow. These echoes appear on screen as countless small echoes continuously changing size, intensity and position. Turning the rain clutter function on suppresses the bulk effect of rain returns from around your vessel, making it easier to recognize other objects. • Sea Gain — radar echoes from waves around your vessel can clutter the center of the radar picture, making it difficult to detect real targets. Adjusting the sea gain reduces this clutter for up to 5 nautical miles (depending on wave and sea conditions) from your vessel. • SuperHD Controls — for SuperHD scanners only: | <p>The digital radar gain presets enable you to quickly select pre-configured settings to achieve the best picture in different situations. Raymarine strongly recommends the use of these presets to achieve optimum results. However, each of the gain presets can be manually adjusted using gain, color gain, rain, and sea gain functions.</p> |

| Tuning method | Related options | Description |
|---|--|---|
| | <ul style="list-style-type: none"> - Antenna Boost: scales the effective antenna size. At zero, the effective antenna size matches its actual size. At 95%, the effective antenna size is doubled. Increasing the effective antenna size separates targets that appear merged at lower settings. - Power Boost: adjusts effective transmit power. At zero, the radar operates at its standard power (4kW or 12kW). At 90, the effective power is increased by a factor of at least two. Increasing the power makes targets more distinct from noise. For maximum benefit, reduce power boost to prevent saturation of strong targets. | |
| <p>Enhance Echoes functions:</p> <ul style="list-style-type: none"> • Interference rejection — this function minimizes the effect of interference from other radar-equipped vessels. • Expansion — enables you to override the default radar pulse length, providing larger target returns. • Wakes — enables you to see the direction and speed of moving targets relative to your vessel. | <p>INT. REJECTION:</p> <ul style="list-style-type: none"> • ON — minimizes the effect of interference from other radar-equipped vessels. • OFF — allows you to detect the presence of other radars in the vicinity. <p>EXPANSION:</p> <ul style="list-style-type: none"> • ON — increases the pulse length. This provides larger target returns, making them easier to see. However, larger returns may decrease target resolution, and merge on the display. • OFF — this is the default setting. It provides better range resolution, giving you more defined (but smaller) target returns. <p>WAKES:</p> <ul style="list-style-type: none"> • ON — shows the direction and speed of moving targets relative to your vessel. Targets are | <p>The enhance echoes functions enable you to minimize the negative effects of echoes on the radar display.</p> |

| Tuning method | Related options | Description |
|---------------|---|---|
| | <p>displayed in yellow, turning to paler shades of blue as the signal diminishes. If you have changed the color palette in use, target colors may be different. The wake options are: 10 sec, 30 sec, 1 min, 5 min, 10 min.</p> <ul style="list-style-type: none"> • OFF — does NOT show the direction and speed of moving targets in relation to your vessel. | |
| Tune control | <ul style="list-style-type: none"> • AUTO — the default mode. The radar tunes itself automatically on all range scales. Raymarine recommends that you leave the tune function in AUTO mode to receive the maximum signal. • MANUAL — enables you to manually set the tuning. Adjust the control to obtain the maximum signal strength. If you adjust the setting shortly after powering up the radar scanner, you should adjust it again approximately 10 minutes after powering up the scanner, as the required setting will change after the magnetron has warmed up. | The radar tuning control enables you to fine-tune the radar scanner's receiver for maximum target returns on the display. |

Selecting digital radar gain presets

These presets require a HD or SHD digital radar scanner. Bird mode requires a scanner with the enhanced bird mode capability.

In the radar application:

1. Press the **GAIN** softkey.
2. Press the **BUOY MODE**, **HARBOUR MODE**, **COASTAL MODE**, **OFFSHORE MODE**, or **BIRD MODE** softkey, as appropriate.

The softkey is highlighted, and the display changes to reflect the new mode.

Adjusting digital radar preset gain

In the radar application:

Using radar

1. Select the **GAIN** softkey.
2. Select the **BUOY MODE**, **HARBOR MODE**, **COASTAL MODE**, **OFFSHORE MODE**, or **BIRD MODE** softkey, as appropriate.
3. Select the same softkey again.
The softkeys change to provide more options.
4. Use the **GAIN** softkey to select the MAN option.
5. Using the rotary controller, adjust the gain control to the appropriate setting (between 0 and 100%).
6. Press the **OK** button.

Adjusting digital radar color gain

In the radar application:

1. Select the **GAIN** softkey.
2. Select the **BUOY MODE, HARBOR MODE, COASTAL MODE, OFFSHORE MODE, or BIRD MODE** softkey, as appropriate.
3. Select the same softkey again.
The softkeys change to provide more options.
4. Use the **COLOR GAIN** softkey to select the MAN option.
5. Using the rotary controller, adjust the gain control to the appropriate setting (between 0 and 100%).
6. Press the **OK** button.

Adjusting digital radar rain clutter

In the radar application:

1. Select the **GAIN** softkey.
2. Select the **BUOY MODE, HARBOR MODE, COASTAL MODE, OFFSHORE MODE, or BIRD MODE** softkey, as appropriate.
3. Select the same softkey again.
The softkeys change to provide more options.
4. Use the **RAIN** softkey to select the ON option.
5. Using the rotary controller, adjust the gain control to the appropriate setting (between 0 and 100%).
6. Press the **OK** button.

Adjusting digital radar sea gain

In the radar application:

1. Select the **GAIN** softkey.
2. Select the **BUOY MODE, HARBOR MODE, COASTAL MODE, OFFSHORE MODE, or BIRD MODE** softkey, as appropriate.
3. Select the same softkey again.
The softkeys change to provide more options.
4. Use the **SEA** softkey to select the MAN option.
5. Using the rotary controller, adjust the gain control to the appropriate setting (between 0 and 100%).

6. Press the **OK** button.

Adjusting SuperHD radar antenna boost

In the radar application:

1. Select the **GAIN** softkey.
2. Select the **BUOY MODE, HARBOR MODE, COASTAL MODE, OFFSHORE MODE, or BIRD MODE** softkey, as appropriate.
3. Select the same softkey again.
The softkeys change to provide more options.
4. Select the **SUPER HD CONTROLS** softkey.
5. Use the **ANTENNA BOOST** softkey to select the MAN option.
6. Using the rotary controller, adjust the gain control to the appropriate setting (between 0 and 100%).
7. Press the **OK** button.

Adjusting SuperHD radar power boost

In the radar application:

1. Select the **GAIN** softkey.
2. Select the **BUOY MODE, HARBOR MODE, COASTAL MODE, OFFSHORE MODE, or BIRD MODE** softkey, as appropriate.
3. Select the same softkey again.
The softkeys change to provide more options.
4. Select the **SUPER HD CONTROLS** softkey.
5. Use the **POWER BOOST** softkey to select the MAN option.
6. Using the rotary controller, adjust the gain control to the appropriate setting (between 0 and 100%).
7. Press the **OK** button.

Enhance echoes functions

Enabling radar interference rejection

In the radar application:

1. Press the **ENHANCE ECHOES** softkey.
2. Press the **INT. REJECTION** softkey repeatedly until the ON option is selected.
3. Press the **OK** button.

Enabling radar expansion

In the radar application:

1. Press the **ENHANCE ECHOES** softkey.
2. Press the **EXPANSION** softkey repeatedly until the ON option is selected.
3. Press the **OK** button.

Enabling radar wakes

In the radar application:

1. Press the **ENHANCE ECHOES** softkey.
2. Press the **WAKES** softkey repeatedly until the ON option is selected.
3. Select the appropriate time period.

Adjusting the radar tune control

In the radar application:

1. Press the **MENU** button.
2. Select the **Radar Setup** menu item.
3. Select the **Scanner Setup** menu item.
4. Select the **Tune** menu item.
5. Select the MANUAL option, using the **TUNE** softkey.
6. Using the rotary control, adjust the level to obtain the maximum signal strength (indicated by the eight-step horizontal bar).
7. Press the **OK** button.

9.9 Radar tuning: non-HD digital radomes

You can use the gain presets and other functions to improve the quality of the radar picture.

The following settings apply to non-HD digital radomes:

| Tuning method | Related Options | Description |
|---------------|---|---|
| Gain | <ul style="list-style-type: none">• AUTO — the preset operates in automatic mode. This is the default.• MAN — allows you to manually adjust the intensity of the gain, from 0 to 100%. | Enables you to adjust the sensitivity of the radar reception. In some situations, adjusting the sensitivity may improve the clarity of the radar picture. |
| FTC function | <ul style="list-style-type: none">• ON — enables the FTC function and allows you to adjust the setting between 0 and 100%.• OFF — disables the FTC function. This is the default. | <p>Enables you to remove areas of clutter at a distance from your vessel. It also helps you to distinguish between two very close echoes on the same bearing, which may otherwise merge and appear as one echo. You can adjust the intensity of the FTC function between 0 and 100%:</p> <ul style="list-style-type: none">• A higher setting shows only the leading edge of large (rain clutter) echoes, while the effect on smaller (ship) echoes is only slight.• A lower setting reduces background noise and fill-in returns from land and other large targets. |
| Rain function | <ul style="list-style-type: none">• ON — enables the Rain function and allows you to adjust the setting between 0 and 100%.• OFF — disables the Rain function. This is the default. | The radar scanner detects echoes from rain or snow. These echoes appear on screen as countless small echoes continuously changing size, intensity and position. Turning the rain clutter function ON suppresses the bulk effect of rain returns from around your vessel, making it easier to recognize other objects. You can adjust the intensity of this setting between 0 and 100%. |

| Tuning method | Related Options | Description |
|--|--|--|
| <p>Sea gain presets:</p> <ul style="list-style-type: none"> • Harbor — this is the default mode. This setting takes account of land clutter so that smaller targets, like navigation buoys, are not lost. • Coastal — accounts for the slightly higher levels of sea clutter you might encounter out of harbor and adjusts the radar display accordingly. • Offshore — Automatically adjusts for high levels of sea clutter. | <ul style="list-style-type: none"> • AUTO — the preset operates in automatic mode. This is the default. • MAN — allows you to manually adjust the intensity of the sea gain, from 0 to 100%. | <p>Enable you to quickly select pre-configured settings to achieve the best picture in different situations. Each of the gain presets has a gain function, which is set to automatic mode by default. Raymarine strongly recommends the use of these presets to achieve optimum results. However, you can adjust this gain manually if required.</p> |
| <p>Enhance Echoes functions:</p> <ul style="list-style-type: none"> • Interference rejection — this function minimizes the effect of interference from other radar-equipped vessels. • Expansion — enables you to override the default radar pulse length, providing larger target returns. • Wakes — enables you to see the direction and speed of moving targets relative to your vessel. | <p>INT. REJECTION:</p> <ul style="list-style-type: none"> • ON — minimizes the effect of interference from other radar-equipped vessels. There are two settings — NORMAL, and HIGH. • OFF — allows you to detect the presence of other radars in the vicinity. <p>EXPANSION:</p> <ul style="list-style-type: none"> • ON — increases the pulse length, giving larger target returns that are easier to see. However, larger returns may decrease target resolution, and merge on the display. There are two settings — LOW and HIGH. • OFF — this is the default setting. It provides better range resolution, giving you more defined (but smaller) target returns. <p>WAKES:</p> <ul style="list-style-type: none"> • ON — you can see the direction and speed of moving targets relative to your vessel. Targets are displayed in yellow, turning to paler shades of blue | <p>The enhance echoes functions enable you to minimize the negative effects of echoes on the radar display.</p> |

| Tuning method | Related Options | Description |
|---------------|---|---|
| | <p>as the signal diminishes. The options are: 10 sec, 30 sec, 1 min, 5 min, 10 min.</p> <ul style="list-style-type: none"> • OFF — you will NOT be able to see the direction and speed of moving targets in relation to your vessel. | |
| Tune control | <ul style="list-style-type: none"> • AUTO — the default mode. The radar tunes itself automatically on all range scales. Raymarine recommends that you leave the tune function in AUTO mode to receive the maximum signal. • MANUAL — enables you to manually set the tuning. Adjust the control to obtain the maximum signal strength. If you adjust the setting shortly after powering up the radar scanner, you should adjust it again approximately 10 minutes after powering up the scanner, as the required setting will change after the magnetron has warmed up. | The radar tuning control enables you to fine-tune the radar scanner's receiver for maximum target returns on the display. |

Adjusting radar gain

In the radar application:

1. Press the **GAIN** softkey.
2. Press the **GAIN** softkey until the MAN option is selected.
3. Using the rotary controller, adjust the gain control to the appropriate setting.

Adjusting the radar FTC function

In the radar application:

1. Press the **GAIN** softkey.
2. Press the **FTC** softkey until the ON option is selected.
3. Using the rotary controller, adjust the FTC function to the appropriate setting.

Adjusting the radar rain function

In the radar application:

1. Press the **GAIN** softkey.
2. Press the **RAIN** softkey until the ON option is selected.
3. Using the rotary controller, adjust the Rain function to the appropriate setting.

Adjusting radar sea clutter

In the radar application:

1. Press the **GAIN** softkey.
2. Press the **SEA** softkey.
3. Select the HARBOR, OFFSHORE, or COASTAL preset, as appropriate.

Note: You can adjust the radar's sensitivity to sea clutter using the **MENU > Radar Setup > Scanner Setup > Sea Clutter Curve** menu item.

4. Select the **Tune** menu item.
5. Select the MANUAL option, using the **TUNE** softkey.
6. Using the rotary control, adjust the level to obtain the maximum signal strength (indicated by the eight-step horizontal bar).
7. Press the **OK** button.

Enhance echoes functions

Enabling radar interference rejection

In the radar application:

1. Press the **ENHANCE ECHOES** softkey.
2. Press the **INT. REJECTION** softkey repeatedly until the ON option is selected.
3. Press the **OK** button.

Enabling radar expansion

In the radar application:

1. Press the **ENHANCE ECHOES** softkey.
2. Press the **EXPANSION** softkey repeatedly until the ON option is selected.
3. Press the **OK** button.

Enabling radar wakes

In the radar application:

1. Press the **ENHANCE ECHOES** softkey.
2. Press the **WAKES** softkey repeatedly until the ON option is selected.
3. Select the appropriate time period.

Adjusting the radar tune control

In the radar application:

1. Press the **MENU** button.
2. Select the **Radar Setup** menu item.
3. Select the **Scanner Setup** menu item.

9.10 Using radar to measure distances, ranges, and bearings

When you are using the radar application, you can measure distances, ranges and bearings in a variety of ways.

These options are detailed in the table below:

| Functions | Distances Between Points | Range From Your Vessel | Bearings |
|---------------------------------|----------------------------|-------------------------|----------|
| Range Rings | Yes (approximate distance) | Yes (approximate range) | No |
| Cursor | No | Yes | Yes |
| Variable Range Markers (VRMs) | No | Yes | No |
| Electronic Bearing Lines (EBLs) | No | No | Yes |
| Floating VRMs | Yes | No | No |
| Floating EBLs | No | No | Yes |

Measuring using the range rings

Use the range rings to gauge the approximate distances between points. Range rings are concentric circles displayed on the screen and centred from your boat at pre-set distances. The number and spacing of the rings changes as you range in and out.

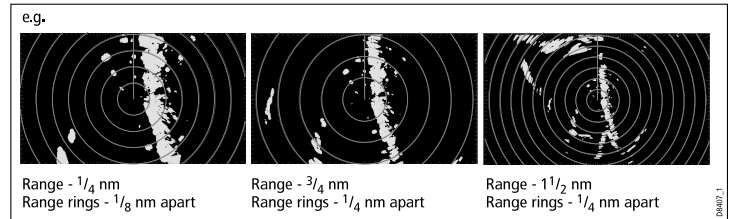

Measuring using the cursor

To measure the bearing and range from your boat to a specified target, move the cursor to the appropriate position on the screen.

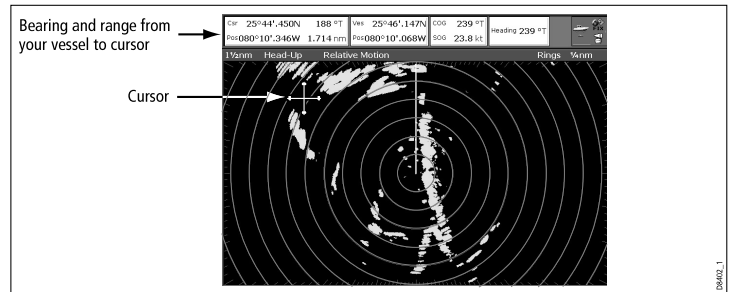

Note: If cursor position is not shown in the Databar, go to **Menu > Databar Setup > Configure**.

Measuring using Variable Range Markers (VRMs)

A Variable Range Marker (VRM) is a circle centred on your vessel's position and fixed with respect to the heading mode. When this circle is adjusted to align with a target, its range from your boat is measured and displayed on the ADJUST VRM softkey. The data is also displayed if you select the VRM with the cursor.

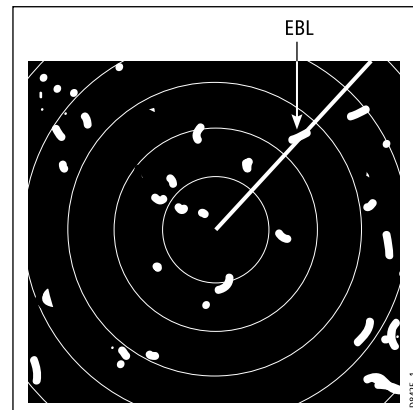
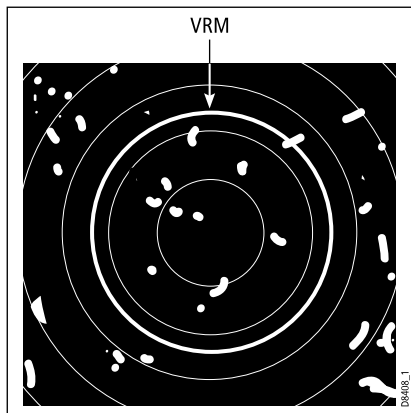

Measuring using Electronic Bearing Lines (EBLs)

An Electronic Bearing Line (EBL) is a line drawn from your boat to the edge of the window. When this line is rotated to align with a target, its bearing relative to your boat's heading is measured and displayed on the ADJUST EBL softkey. The data is also displayed if you select the EBL with the cursor.

Note: The default bearing mode for EBLs is relative to your vessel's heading. If heading data is available, you can set the bearing mode to be relative (REL), magnetic/true (M/T). When M/T is selected, the EBL bearings will be expressed as either true or magnetic, dependant on the equipment connected. The current EBL bearing is shown on both the radar screen EBL label and on the ADJUST EBL softkey.

Measuring using combined VRM and EBL

A VRM and an EBL can be combined to measure both the range and the bearing of the specified target.

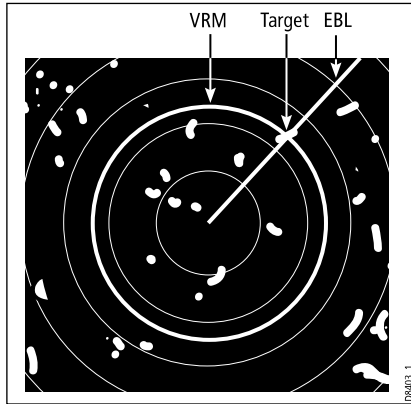

Measuring using floating VRM and EBL

You can use the VRM/EBL float function to measure the range and bearing between any two points on the radar screen. This function allows you to move the VRM/EBL centre away from your boat's position and onto a target. You can then change the radius of the VRM to determine the distance between two points and change the angle of the EBL, relative to its new origin, to obtain the bearing.

Creating a VRM or EBL on the radar display

In the radar application:

1. Select the **VRM/EBL** softkey.
2. Select the ON option using the **VRM/EBL 1** softkey.
3. Using the rotary control, adjust the VRM to the required size.
4. Select the **ADJUST EBL** softkey.
5. Using the rotary control, adjust the EBL to the required angle.
6. Press the **OK** button to save the settings.
7. Repeat Steps 1 to 6 to create a second VRM/EBL if required, this time using the **VRM/EBL 2** softkey.

Note: The first VRM/EBL will be placed at a location of 1/3 of the current range and 030° relative to your vessel's head. If this setting is adjusted, the display will retain the adjustments and use them when the VRM/EBL is next enabled.

Creating a floating VRM or EBL on the radar display

In the radar application:

1. If you have already created a VRM or EBL, skip to Step 8. Otherwise, follow Steps 2 to 12.
2. Select the **VRM/EBL** softkey.
3. Select the ON option using the **VRM/EBL 1** softkey. The VRM/EBL is displayed.
4. Select the **ADJUST VRM** softkey.
5. Using the rotary control, adjust the VRM to the required size.
6. Select the **ADJUST EBL** softkey.
7. Using the rotary control, adjust the EBL to the required angle.
8. Position the cursor over the VRM or EBL. The softkeys change to display the VRM/EBL options.
9. Select the **FLOATING EBL** softkey.
10. Select the **ADJUST FLOAT** softkey.
11. Using the trackpad, move the center position of the circle to the desired position.
12. Press the **CANCEL** button to deselect the **ADJUST FLOAT** softkey, and then **CANCEL** again to return to the previous level of softkeys. The **ADJUST VRM** softkey displays the distance. The **ADJUST EBL** softkey displays the bearing.

Note: When creating the first VRM/EBL, it will be placed at a location of 1/3 of the current range and 030° relative to your vessel's head. If this setting is adjusted, the display will retain the adjustments and use them when the VRM/EBL is next enabled.

2. Select **Radar Setup**.
3. Use the **Range Rings** menu option to switch Radar Rings ON or OFF.

Unfloating a VRM or EBL on the radar display

In the radar application:

1. Select the **VRM/EBL** softkey.
2. Use the **VRM/EBL 1** softkey to select the ON option.
3. Select the **FLOATING EBL** softkey.
4. Select the **CENTER** softkey.

Using the radar range rings

Radar range rings enable you to measure the distance between two points on the radar display.

Use the range rings to gauge the approximate distances between points. Range rings are concentric circles displayed on the screen and centred from your boat at pre-set distances. The number and spacing of the rings changes as you range in and out.

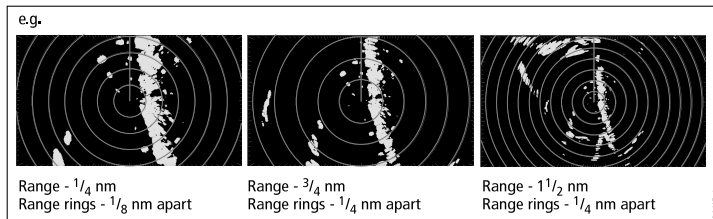

Enabling and disabling radar range rings

In the radar application:

1. Press the **MENU** button.

Using radar

9.11 Using radar to track targets and avoid collisions

There are a number of radar functions to help you track targets and avoid collisions, including Guard Zones, MARPA, and AIS.

With a radar connected to your multifunction display, you can:

- Assess how far away a target is and its bearing (VRMs/EBLs).
- Set an alarm to trigger when a target is within a specified zone (Guard Zones).
- Display detailed information on tracked targets (MARPA).
- Display the identity of other vessels and if broadcasted, their voyage information (AIS).
- Display the range and bearing of a target.

Setting up a radar guard zone

In the radar application:

1. Press the **TARGET TRACKING** softkey.
2. Press the **MONITOR IN ZONES** softkey.
3. Press the **ZONE 1** or **ZONE 2** softkey (as appropriate) until the ON or OFF option is selected.
4. Press the **SET UP ZONE 1** or **SET UP ZONE 2** softkey, as appropriate.
5. Press the **ZONE SHAPE** softkey until the SECTOR or CIRCLE option is selected, as required.
6. Use the softkeys and the rotary control to specify the guard zone, as appropriate.

Adjusting guard zone sensitivity

1. Press the **MENU** button.
2. Select **Alarm Setup**.

3. Select **Radar Alarms Setup**.
4. Select **Guard Zones Sensitivity**.
5. Use the rotary control or trackpad to adjust the sensitivity.

MARPA overview

MARPA is used for target tracking and risk analysis in the radar application.

With an accurate heading sensor connected to your multifunction display, you can use the Mini Automatic Radar Plotting Aid (MARPA) functions for target tracking and risk analysis. MARPA improves collision avoidance by calculating information for tracked targets, and provides continuous, accurate, and rapid situation evaluation. The number of targets that you can track at any one time is dependent on the model of radar scanner that you are using.

MARPA tracks acquired targets, and calculates the target's speed and course.

Each target tracked can be displayed with a graphic indicating the Closest Point of Approach (CPA), and Time to Closest Point of Approach (TCPA). The calculated target data can also be shown on your screen. Each target is continually assessed and an audible alarm is sounded if a target becomes dangerous, or is lost.

For effective MARPA operation, your multifunction display must have accurate heading and speed data for your vessel. The better the quality of the heading and speed data, the better MARPA will perform. For the best heading data, a Raymarine SMART heading sensor or a gyro-stabilized autopilot is required.

In True Motion mode, Speed Over Ground (SOG) and Course Over Ground (COG) information is required to show true target course and speed.

In Relative Motion mode, heading and speed information is required.

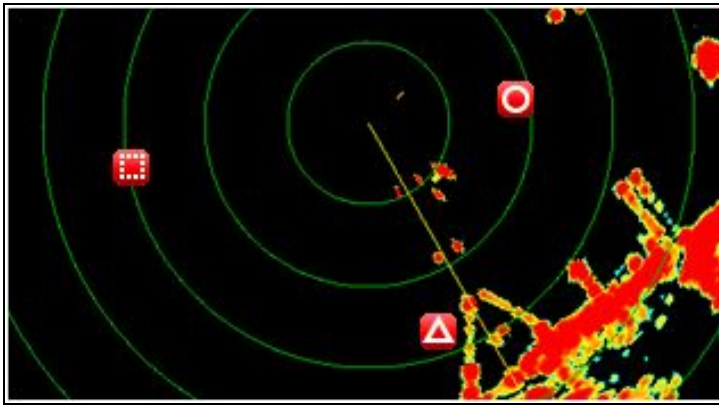

- the symbol wanders away from the target, locks-on to another target, or changes to a lost symbol target.

In these circumstances, target acquisition and tracking may need to be re-initiated and in some cases might be impossible to maintain. Better quality heading data might improve performance in these circumstances.

How a MARPA risk is assessed

Each target is monitored to ascertain whether it will be within a certain distance from your vessel within a certain time. If so, the target is designated as dangerous, and an audible warning is sounded and a warning displayed. The target symbol changes to the dangerous target symbol and flashes to indicate that it is a dangerous target. Selecting the appropriate softkey will silence the alarm and remove the warning.

If a target is lost, either because the MARPA software has lost contact with it, or because it has moved out of range, an audible alarm is sounded and an on-screen warning appears. The on-screen symbol will change to the target lost symbol. Selecting the appropriate softkey will silence the alarm and remove the on-screen warning and the target lost symbol.

Effective range for MARPA targets

MARPA target acquisition is only available at radar range scales of up to 12 nm, although tracking continues at all ranges.

If you change to a smaller range scale, targets may be beyond the range of your radar scanner and will be lost. In such cases, an on-screen warning indicates that the target is off-screen.

Status symbols for MARPA targets

Each target is shown in the radar application as a symbol, indicating its status:

Safety notices

MARPA can improve collision avoidance when used wisely. It is your responsibility to exercise common prudence and navigational judgement.

There are conditions where acquiring a target may become difficult. These same conditions may be a factor in successfully tracking a target. Some of the conditions are:

- The target echo is weak. The target is very close to land, buoys or other large targets.
- The target or your own vessel is making rapid manoeuvres.
- Choppy sea state conditions exist and the target is buried in excessive sea clutter or in deep swells.
- Choppy sea state conditions exist yielding poor stability; own vessel's heading data is very unstable.
- Inadequate heading data.

Symptoms of such conditions include:

- target acquisition is difficult and the MARPA vectors are unstable;



Target being acquired



Dangerous target



Safe target



Lost target

07562_2

Vessel vectors (CPA graphics) overview

CPA graphics show vectors for your vessel and a selected target.

A vector is a line on-screen showing the predicted courses of your vessel and the selected target if you both remain on your present course. These vectors vary in length due to vessel speed and vector length set in the MARPA Setup menu.

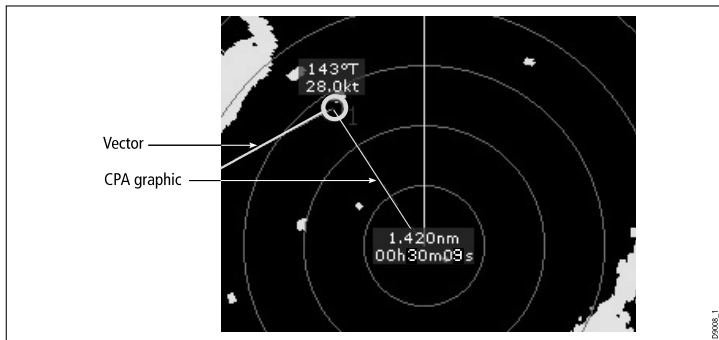

True mode

With the display set in True mode, the vectors of your vessel and the target are shown extended to their intersection point. The CPA is shown as a line that is placed on your vessel's vector at the point of the CPA. The length and direction of the line indicates the distance and bearing of the target at CPA. The text indicates CPA and TCPA. The text next to the target symbol indicates its true course and speed.

Relative mode

With the display set in Relative mode, no vector extension of your vessel is shown. The CPA line emerges from your own vessel, with the target vector extension being shown as relative, not true. The text next to the target indicates its course and speed.

Configuring MARPA and AIS options

In the radar application:

1. Select the **TARGET TRACKING** softkey.
2. Select the **MARPA AND AIS OPTIONS** softkey.
3. Select the **Vector Length** menu item and adjust the time period as appropriate. The distance that your vessel travels in the time period you specify here determines the length of the vector lines.
4. Select the **Target History** menu item to adjust the interval by which a target's previous position is plotted on the radar display.
5. Select the **Own Vessel Safe Zone** menu item to specify the range of your safe zone. A target is considered dangerous if it comes within this range.
6. Select the **Time To Safe Zone** menu item to specify the time period of your safe zone. A target is considered dangerous if it enters the safe zone within this time period.
7. Select the **Safe Zone Ring** menu item to show or hide the safe zone on the radar display.

Displaying vessel vectors (CPA graphics)

1. Position the cursor over the target.
2. To display the CPA graphic for the target, press the **CPA GRAPHIC** softkey until the ON option is selected.
3. To hide the CPA graphic for the target, press the **CPA GRAPHIC** softkey until the OFF option is selected.
4. To display the CPA graphic automatically when you place the cursor over any part of the MARPA symbol, select the AUTO option.
5. Press the **OK** button.

MARPA options

The MARPA options are accessible by pressing the **TARGET TRACKING > MARPA & AIS OPTIONS** softkeys.

| Parameter | Descriptions | Options |
|-----------------------------|---|--|
| Vector Length | The time period specified for drawing length of vectors. | <ul style="list-style-type: none"> • 0.5 min • 1 min • 3 min • 6 min • 12 min • 30 min • 60 min |
| Target History | Plots a target's previous position at specified intervals. The four most recent position points are displayed. If True target vectors are selected, the four most recent vessel position points are also displayed. | <ul style="list-style-type: none"> • OFF • 0.5 min • 1 min • 3 min • 6 min |
| Own Vessel Safe Zone | The safe zone is a ring, centred on your boat, within which a target is considered dangerous if it will enter this zone within the Time to Safe Zone period (see below). | <ul style="list-style-type: none"> • 0.1 nm • 0.2 nm • 0.5 nm • 1.0 nm • 2.0 nm |

| Parameter | Descriptions | Options |
|--------------------------|--|--|
| Time to Safe Zone | If a target enters your safe zone within this time period, it is considered dangerous. | <ul style="list-style-type: none"> • 3 min • 6 min • 12 min • 24 min |
| Safe Zone Ring | Controls whether the safe zone ring is displayed or hidden on screen. | <ul style="list-style-type: none"> • Visible • Hidden |

Using MARPA

Acquiring a MARPA target to track

In the radar application:

1. Select the **TARGET TRACKING** softkey.
2. Move the cursor over the target to be acquired.
3. Select the **ACQUIRE TARGET** softkey.

The “target being acquired” symbol is displayed. If the target is present for several scans, the radar locks-on to the target, and the symbol changes to “safe target” status.

Cancelling a MARPA target

In the radar application:

1. Move the cursor over the relevant target.
2. Press the **CANCEL TARGET** softkey.
3. Alternatively, display the MARPA target list by pressing the **TARGET TRACKING**, then **MARPA LIST** softkeys.
4. Using the trackpad, select the relevant MARPA target from the list.
5. Press the **CANCEL TARGET** softkey.

9.12 Radar setup menu options

The Radar Setup menu enables you to configure the performance and behaviour of your radar scanner.

| Function | Description | Options |
|-----------------------|--|--|
| Select Scanner | Select the radar scanner that you want to use. | |
| Scanner Setup | <p>This menu item contains a sub-menu that enables you to adjust the settings for the following functions:</p> <ul style="list-style-type: none"> • Scanner Speed — this option is only available with scanners that support multiple speeds. Two speeds are available — 24 RPM and Auto. You must select the AUTO option if you want to use the 48 RPM scan speed. • Tune Adjust — allows you to fine tune the radar scanner’s receiver for maximum returns on the display. Raymarine recommends that this function is set to AUTO. If you set this function to MANUAL and adjust the setting shortly after powering up the radar scanner, you should adjust it again approximately 10 minutes after powering up the scanner, as the required setting will change after the magnetron has warmed up. • Sea Clutter Curve — radar echoes from waves can make it difficult to detect real targets. These echoes are known as “sea clutter”. Several factors can affect the level of clutter you see, including the weather and sea conditions, and the mounting height of the radar. The sea clutter curve setting adjusts the radar’s sensitivity to sea clutter. The steepest setting for the curve is 1, and the most shallow setting is 8. • Parking Offset (Digital only) — this setting is only available when the radar is set to Off or Standby. The parking offset determines how the scanner is aligned to the pedestal. The default setting is 0 degrees, with the scanner aligning to the pedestal, facing forwards. • Antenna Size — this is used to specify the size of your radar scanner. | <p>Scanner Speed</p> <ul style="list-style-type: none"> • 24 RPM • Auto <p>Tune Adjust</p> <ul style="list-style-type: none"> • AUTO • MANUAL <p>Sea Clutter Curve</p> <ul style="list-style-type: none"> • ADJUST CURVE (1 to 8) <p>Parking Offset</p> <ul style="list-style-type: none"> • 0 to 358 degrees, in two-degree increments. <p>Antenna Size</p> <ul style="list-style-type: none"> • Radome • 4’ Array • 6’ Array |
| Range Rings | Enables or disables Range Rings, which help you to determine distances and ranges. | <ul style="list-style-type: none"> • Off • On |

| Function | Description | Options |
|-------------------------------------|---|--|
| Color Palette (Digital only) | <p>The color palette options enable you to customize the look of the radar display for different situations, as follows:</p> <ul style="list-style-type: none"> • Bold — uses high color gain, predominately red, to show weak targets more intensely. • Professional 1 — high resolution palette that uses the full color range to display the information discovered by the scanner, just the strong returns are red. • Professional 2 — high resolution palette, displays weaker targets in browns with more intense targets displayed in yellows. • Pathfinder — similar to the Pathfinder color palette. • Night Vision — green. | <ul style="list-style-type: none"> • Bold • Professional 1 • Professional 2 • Pathfinder • Night Vision |
| EBL Reference | The measurement point used for reference when measuring distances using Electronic Bearing Lines (EBLs) and range rings in the chart application. The options are Magnetic/True North, or Relative. | <ul style="list-style-type: none"> • Mag/True • Relative |
| Timed Transmit | Controls the radar's timed transmission power-save mode. | <ul style="list-style-type: none"> • On • Off |
| Transmit Period | When ON, the scanner performs the number of scans specified and then shuts down for the number of minutes specified by the Standby Period setting. | <ul style="list-style-type: none"> • 10 SCANS • 20 SCANS • 30 SCANS |
| Standby Period | Indicates the number of minutes that the system shuts down - the scanner does not rotate and the display is in standby mode. | <ul style="list-style-type: none"> • 3 MINS • 5 MINS • 10 MINS • 15 MINS |
| Bearing Alignment | Enables you to make corrections for display azimuth error. | Refer to Installation Guide |
| Radar Advanced Setup | Advanced setup options. | Refer to Installation Guide |

Chapter 10: Using AIS

Chapter contents

- [10.1 AIS overview on page 150](#)
- [10.2 AIS prerequisites on page 151](#)
- [10.3 Classes of AIS data on page 152](#)
- [10.4 Enabling AIS on page 153](#)
- [10.5 Displaying AIS vectors on page 153](#)
- [10.6 AIS status symbols on page 154](#)
- [10.7 AIS silent mode on page 154](#)
- [10.8 Viewing AIS target information on page 155](#)
- [10.9 Using AIS to avoid collisions on page 156](#)
- [10.10 AIS options on page 157](#)
- [10.11 AIS alarms on page 158](#)
- [10.12 Buddy tracking on page 159](#)
- [10.13 Aid to Navigation \(AToN\) targets on page 161](#)
- [10.14 Land base station targets on page 162](#)

10.1 AIS overview

The AIS feature enables you to receive information broadcast by other vessels, and to add these vessels as targets in the chart and radar applications.

With an optional AIS unit connected to your system you can:

- Display targets for any other AIS-equipped vessels.
- Display voyage information being broadcast by these targets, such as their position, course, speed and rate-of-turn.
- Display basic or detailed information for each target vessel, including safety-critical target data.
- Set up a safe zone around your vessel.
- View AIS alarm and safety-related messages.

AIS information is displayed in the form of an overlay in the chart and radar applications. Additional data is displayed in a dialog box in the chart application, for example:

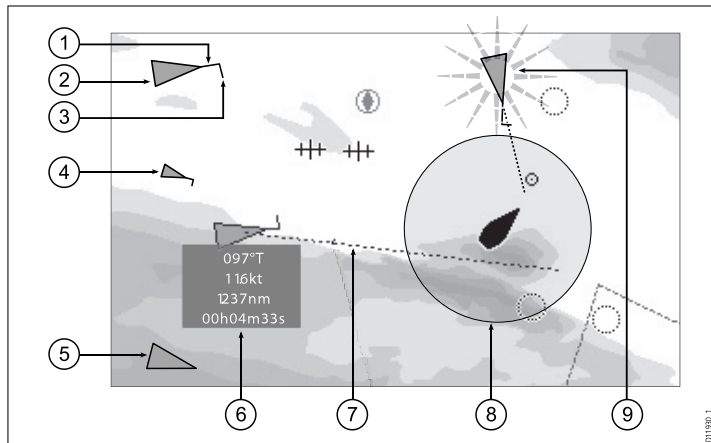

1. Heading.
2. Large vessel.
3. Direction of turn.
4. Small vessel.
5. Transmitting target.
6. Safety-critical data.
7. COG / SOG vector.
8. Safe zone (defined by distance or time).
9. Dangerous target (flashes).

AIS-equipped vessels in the surrounding area are displayed in the chart or radar application as triangular targets. Up to 100 targets are displayed. As the vessel's status changes, the symbol for the target changes accordingly.

Vectors can be displayed for each target. These vectors indicate the direction of travel and rate of turn of the vessel and the distance it will travel over a specified period of time (COG / SOG vector). Targets displayed with their vectors are referred to as 'active targets' and are scaled according to the size of the vessel. The larger the vessel, the larger the target. You can either display all targets or just dangerous targets.

How AIS Works

AIS uses digital radio signals to broadcast 'real-time' information between vessels and shore-based stations via dedicated VHF radio frequencies. This information is used to identify and track vessels in the surrounding area and to provide fast, automatic and accurate collision avoidance data. The AIS features complement the radar application, as AIS can operate in radar blind spots and can detect smaller vessels equipped with AIS.

Note: It may not be mandatory for vessels to be fitted with operational AIS equipment. Therefore, you should not assume that your multifunction display will show ALL vessels in your area. Due prudence and judgement should be exercised. AIS should be used to complement radar, NOT substitute it.

AIS Simulator Mode

Raymarine recommends that you use the simulator function to familiarize yourself with the AIS features. When the simulator function is enabled (**Menu > System Setup > Simulator**), it displays 20 AIS targets within a 25 nm range. These targets are displayed using the appropriate AIS target's status symbol, and move around the screen as if they were real targets.

Note: Incoming safety messages are NOT displayed while the simulator is enabled.

10.2 AIS prerequisites

You must have suitable AIS hardware connected to your multifunction display to make use of the AIS functionality.

In order to run AIS, you will need:

- A receive-only AIS unit or a full AIS transceiver (a unit that sends and receives).
- A VHF antenna - this is usually supplied with the AIS system.
- A GPS - to provide position data.
- The AIS layer enabled in the chart or radar application, as appropriate.

Note: A receiver will allow you to receive data about other vessels in your area but will not allow other vessels to 'see' you. A full transceiver transmits and receives AIS data, and therefore allows you to receive data about other vessels. It also enables other AIS-equipped vessels to see and receive information about your vessel. This could include position, course, speed and rate of turn data.

When the AIS unit is connected to your multifunction display, the status of the unit is indicated by an AIS icon in the transducer data box.

You can connect an AIS unit to your multifunction display using NMEA0183 or SeaTalk^{ng}, depending on the AIS unit. If connecting using NMEA0183, you will now need to specify the 38,400 baud setting (**Menu > System Setup > System Integration > NMEA Port Setting**) for the NMEA port that communicates with the AIS transceiver or receiver.

10.3 Classes of AIS data

There are 2 classes of AIS data; each class supports a different range of AIS data.

AIS data is defined as Class A or Class B. The sending and receiving of Class A and Class B data may not be compulsory for all vessels. Therefore, you should NOT assume that your multifunction display is showing all vessels in your area.

Note: Not all AIS units will decode all the available AIS information. For example, some AIS Class B receivers do not decode and output information such as the vessel's name, IMO number, vessel draft / beam / length, and destination. Additionally some Class A vessels do not input all of the required AIS data, in which case the information will not be shown on your multifunction display.

Your AIS receiver or transceiver may support additional AIS data that is not shown on your multifunction display.

The following table lists the AIS information that is shown on your multifunction display:

| Data | Class A (receive) | Class B (send) | Class B (receive) |
|-----------------|-------------------|----------------|-------------------|
| Vessel's name | ✓ | ✓ | ✓ |
| Type | ✓ | ✓ | ✓ |
| Call sign | ✓ | ✓ | ✓ |
| IMO number | ✓ | ✗ | ✗ |
| Length and beam | ✓ | ✓ | ✓ |

| Data | Class A (receive) | Class B (send) | Class B (receive) |
|---------------------|-------------------|----------------|-------------------|
| Antenna location | ✓ | ✓ | ✓ |
| Draft | ✓ | ✗ | ✗ |
| Cargo Information | ✓ | ✓ | ✓ |
| Destination | ✓ | ✗ | ✗ |
| ETA | ✓ | ✗ | ✗ |
| Time | ✓ | ✓ | ✓ |
| Vessel's position | ✓ | ✓ | ✓ |
| COG | ✓ | ✓ | ✓ |
| SOG | ✓ | ✓ | ✓ |
| Gyro heading | ✓ | ✓ | ✓ |
| Rate of turn | ✓ | ✗ | ✗ |
| Navigational status | ✓ | ✗ | ✗ |
| Safety message | ✓ | ✗ | ✓ |

10.4 Enabling AIS

Enabling AIS in the chart application

In the 2D chart view:

1. Select the **2D CHART LAYERS** softkey.
2. Use the **AIS TARGETS** softkey to select the ON option.

Enabling AIS in the radar application

In the radar application:

1. Select the **PRESENTATION** softkey.
2. Use the **AIS LAYER** softkey to select the ON option.

10.5 Displaying AIS vectors

You must have the correct data available before AIS vectors can be displayed.

A target is defined as active when it has the following data displayed graphically:

- A COG/SOG vector indicating the predicted distance that a target will travel within a given period of time.
- A heading and direction of turn indicator.

Enabling and disabling AIS vectors







In the chart or radar application:

1. Move the cursor over the relevant AIS target.
2. Press the **AIS VECTOR** softkey until the ON or OFF option is selected, as appropriate.
3. Press the **OK** button.

Note: The same target vector and safe zone settings apply to both radar MARPA and AIS targets.

10.6 AIS status symbols

AIS status is indicated by a symbol in the databar.

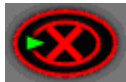
| Symbol | Description |
|--|--|
|  | AIS unit is switched on and operating. |
|  | AIS currently unavailable. |
|  | AIS unit is switched off, or not connected. |
|  | AIS unit is in Silent Mode. |
|  | AIS unit is in Silent Mode, with active alarms. |
|  | AIS unit is connected and switched on, but has active alarms. |
|  | AIS unit is connected and switched on, but the dangerous and lost alarm is disabled. |

10.7 AIS silent mode

AIS silent mode enables you to disable AIS transmissions

AIS silent mode enables you to disable the transmitting functions of your AIS equipment. This is useful when you do not want to transmit your vessel's AIS data to other AIS receivers, but still wish to receive data from other vessels.

Note: Not all AIS equipment supports silent mode. For more information, refer to the documentation that accompanies your AIS unit.

Enabling and disabling AIS silent mode

In the chart or radar application:

1. Press the **MENU** button.
2. Select the **AIS Layer Setup** menu item.
3. Select the ON or OFF option for the **Silent Mode** option, as appropriate.

10.8 Viewing AIS target information

You can display information relating to individual AIS targets.







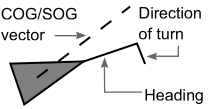
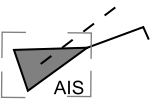

When a target is highlighted with the cursor, the softkeys change to allow you to select the following options:

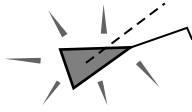
- AIS vectors.
- AIS safety critical data.
- AIS list.
- Full AIS data.

AIS target symbols

Your multifunction display shows a range of symbols to represent the different types of AIS target.

| Target type | Description | Symbol |
|---------------------|--|---|
| Transmitting target | Target not activated, dangerous or lost. Target is moving or at anchor. |  |
| Activated target | Target activated — that is, AIS vector displayed. Vector line (optional) shows predicted distance travelled within a given time. |  |
| Selected target | Target selected with cursor. Can activate the target and view detailed data. |  |

| Target type | Description | Symbol |
|---|---|---|
| Dangerous target | Targets within specified distance (CPA) or time (TCPA). Dangerous target alarm sounds if enabled. Target flashes. |  |
| Uncertain target | Calculated CPA / TCPA value uncertain. |  |
| Lost target | When signal of dangerous target not received for 20 seconds. Target in latest predicted position. Alarms sounds if enabled. Target flashes. |  |
| Buddy target | Target has previously been added to the Buddy List. |  |
| Aid To Navigation (AToN) target (Real) | AToN target is ON position. |  |
| Aid To Navigation (AToN) target (Real) | AToN target is OFF position. |  |
| Aid To Navigation (AToN) target (Virtual) | AToN target is ON position. |  |
| Aid To Navigation (AToN) target (Virtual) | AToN target is OFF position. |  |
| Land base station target | Land base station target is ONLINE. |  |

Displaying detailed AIS target information

In the chart or radar application:

1. In the chart application, select the **AIS OPTIONS** softkey (or **RADAR AND AIS** softkey if Radar Overlay is ON).
2. In the radar application, select the **TARGET TRACKING** softkey.
3. Select the **AIS LIST** softkey.
4. Select the **VIEW FULL AIS DATA** softkey.

Note: You can also display full AIS information by moving the cursor over the relevant target in the chart or radar application, and selecting the **VIEW FULL AIS DATA** softkey.

10.9 Using AIS to avoid collisions

You can use the AIS safe zone and safety message functions to help you avoid collisions with other vessels and objects.

Safe Zones

A safe zone is a ring centred on your vessel within which a target is considered dangerous. It is displayed in the radar or chart applications as a red ring.

This AIS safe zone uses the same criteria as MARPA and will deem a target dangerous if it comes within a specified distance of your vessel (closest point of approach or CPA) within a specified time (time to closest point of approach or TCPA). The CPA and TCPA are calculated using COG/SOG and position from the AIS target.

When your system recognizes a dangerous AIS target:

- The target symbol changes to red and flashes.
- An alarm pop-up is displayed (this can be disabled if required).
- An alarm sounds (this can be disabled if required).

Note: When the AIS receiver is connected and functioning, the system will check for dangerous targets within the safe zone and if enabled issue an alarm whenever necessary. Dangerous target alarm operates irrespective of the ON or OFF status of the AIS target display, or the VISIBLE / HIDDEN status of the safe zone ring.

Safety Messages

When the status of the AIS Safety Messages function is set to ON in the **Menu > AIS Layer Setup Menu**, any incoming safety messages from surrounding vessels, shore stations and mobile stations are displayed in a pop-up box. If known, the message will include the sending vessel's position in latitude / longitude. You will have the option to:

- Remove the message (**ACKNOWLEDGE**).

- Place a waypoint on your chart / radar to mark the sending vessel's position.
- Select to GOTO the sending vessel's position.

Note: You will NOT receive any safety messages in Simulator mode (**Menu > System Setup > Simulator**).

Displaying safety-critical AIS information

In the chart or radar application:

1. Move the cursor over the relevant AIS target.
2. Press the **AIS DATA** softkey until the ON option is highlighted.
3. Press the **OK** button.

10.10 AIS options

The AIS options are accessible in the chart application by pressing the AIS OPTIONS > MARPA & AIS OPTIONS softkeys, or the radar application by pressing the TARGET TRACKING > MARPA & AIS OPTIONS softkeys.

| Parameter | Description | Options |
|----------------|---|--|
| Vector Length | The time period specified for drawing length of vectors. | <ul style="list-style-type: none"> • 0.5 min • 1 min • 3 min • 6 min • 12 min • 30 min • 60 min |
| Target History | Plots a target's previous position at specified intervals. The four most recent position points are displayed. If True target vectors are selected, the four most recent vessel position points are also displayed. | <ul style="list-style-type: none"> • OFF • 0.5 min • 1 min • 3 min • 6 min |

| Parameter | Description | Options |
|-----------------------------|--|--|
| Own Vessel Safe Zone | The safe zone is a ring, centred on your boat, within which a target is considered dangerous if it will enter this zone within the Time to Safe Zone period (see below). | <ul style="list-style-type: none"> • 0.1 nm • 0.2 nm • 0.5 nm • 1.0 nm • 2.0 nm |
| Time to Safe Zone | If a target enters your safe zone within this time period, it is considered dangerous. | <ul style="list-style-type: none"> • 3 min • 6 min • 12 min • 24 min |
| Safe Zone Ring | Controls whether the safe zone ring is displayed or hidden on screen. | <ul style="list-style-type: none"> • Visible • Hidden |

10.11 AIS alarms

The AIS functions generate a number of alarms to alert you to dangerous or lost targets.

In addition to the dangerous target alarm previously described, the system generates an alarm when a dangerous target becomes a lost target i.e. its signal has not been received for 20 seconds.

Your AIS receiver generates local alarms which are displayed and sounded on your multifunction display whenever an alarm condition exists on the unit.

Local AIS alarms

When the connected AIS unit generates an alarm, your multifunction display shows a local alarm message and indicates the alarm status in the data bar icon.

Active AIS alarms list

The active alarm list shows the status of each local alarm. This list can either be accessed via the **Menu > AIS Layer Setup Menu**, or from the **Menu > Alarms Setup Menu**.

Note: When local AIS alarms are acknowledged, the target is shown as dangerous (flashing, with a red outline), and the active alarm status icon is displayed until the target is no longer dangerous.

Acknowledging AIS alarms

In the chart or radar application:

1. Press the **ACKNOWLEDGE** softkey.

Note: An AIS alarm remains active until it is acknowledged on your multifunction display.

10.12 Buddy tracking

You can configure your display to notify you when an AIS-equipped friend or “buddy” comes within range of your vessel.

The Buddy Tracking feature enables you to add AIS-equipped friends and regular contacts to a “Buddy List” on your multifunction display. As soon as a vessel on your Buddy List sails into the range of your AIS receiver, the vessel icon changes to indicate this.



| Item | Description |
|------|-----------------------|
| 1 | Buddy icon |
| 2 | Dangerous target icon |
| 3 | Normal AIS icon |

How it works

When the AIS Layer is enabled in the chart or radar application, AIS targets are shown on your display. You can add any AIS target to a “Buddy List”, each entry consisting of an MMSI number, and an optional name. Subsequently, whenever Buddy Tracking is enabled on your multifunction display, and a “Buddy” vessel with an MMSI number sails into the range of your AIS receiver, an AIS Buddy icon is displayed. Up to 100 vessels may be added to the Buddy List.

Pre-requisites

The following items are required for the Buddy Tracking feature:

- For the purposes of using the Buddy Tracking feature, it is assumed that your display is already connected to a suitable AIS receiver.
- Only AIS-equipped vessels will be detected.

Enabling and disabling buddy tracking

In the chart or radar application, with the AIS Targets layer enabled:

1. Press the **MENU** button.
2. Select **AIS Layer Setup**.
3. Use the **Buddy Tracking** menu item to select the ON or OFF option, as appropriate.

Adding a vessel to your buddy list

In the chart or radar application:

1. Using the trackpad, move the cursor over an AIS target. The softkeys change to reflect this and give you Buddy-related options.
2. Press the **ADD TO BUDDY LIST** softkey.

The MMSI and vessel name are automatically added to the Buddy List.

Adding a vessel to your buddy list from AIS target list

1. If you are in the chart application, press the **AIS OPTIONS** softkey.
2. If you are in the radar application, press the **TARGET TRACKING** softkey.
3. Press the **AIS LIST** softkey.
The AIS Target List is displayed.
4. Using the trackpad, select the AIS target that you want to add to your Buddy List.
5. Press the **ADD TO BUDDY LIST** softkey.
6. Press the **OK** button.

Adding a vessel to your buddy list from main menu

In the chart or radar application:

1. Press the **MENU** button.
2. Using the trackpad, select the AIS LAYER SETUP menu item.
3. Using the trackpad, select the VIEW BUDDY LIST menu item.
4. Press the **ADD VESSEL** softkey.
5. In the MMSI field, enter a valid MMSI number (nine digits).
6. Press the **OK** button.
7. In the NAME field, use the trackpad to enter a name. This could be the name of the vessel, or the name of the friend that owns the vessel, for example.
8. Press the **OK** button.

Editing a buddy's details

1. In the chart or radar application, use the trackpad to move the cursor over an AIS target.
The softkeys change to reflect this and give you Buddy-related options.
2. Alternatively, press the **MENU** button, and select the AIS Layer Setup menu.
3. Press the **VIEW BUDDY LIST** softkey.
The AIS Buddy List dialog is displayed.
4. Press the **EDIT VESSEL DETAILS** softkey.
The Edit Buddy Vessel dialog is displayed.
5. In the MMSI field, edit the MMSI number (nine digits) if required.
6. (Optionally) In the NAME field, edit the existing name, or enter a new name. This could be the name of the vessel, or the name of the friend who owns the vessel, for example.
7. Press the **OK** button.

Deleting a buddy

1. In the chart or radar application, use the trackpad to move the cursor over an AIS target.
The softkeys change to reflect this and give you Buddy-related options.
2. Alternatively, press the **MENU** button, and select the AIS Layer Setup menu.
3. Press the **VIEW BUDDY LIST** softkey.
The AIS Buddy List dialog is displayed.
4. Using the trackpad, highlight the Buddy that you want to delete.
5. Press the **DELETE VESSEL** softkey.
A dialog is displayed, asking you to confirm the deletion.
6. Select YES to confirm that you wish to delete the buddy, or NO to abort.
7. Press the **OK** button.

Displaying additional buddy information

In the chart or radar application:

1. Using the trackpad, move the cursor over an AIS target.
The softkeys change to reflect this and give you Buddy-related options.
2. Press the **BUDDY DATA AUTO ON OFF** softkey.
3. Select the **ON** option.
The Buddy's details are displayed.
4. Press the **OK** button.

10.13 Aid to Navigation (AToN) targets

With an AIS unit connected by NMEA 0183 your system can display Aid to Navigation (AToN) targets.



AToN targets represent shore-based or mobile stations that have been equipped with AIS technology. They broadcast information such as their location, approximately every 3 minutes.



These stations may also be programmed to provide other navigation safety information, for example, meteorological and hydrological data. However, not all information broadcast by AToN targets is currently supported by your multifunction display.

The following AToN target information is supported by your multifunction display, and will be shown in the chart or radar applications when you position the cursor over an AToN target and press the **VIEW FULL AIS DATA** softkey:

- Name.
- Type.
- Position.
- Status.
- Off / On position.
- MMSI.
- Dimensions.
- CPA.
- TCPA.
- Last seen.

AToN targets are shown in the radar and chart applications as:

| Icon | Description |
|--|--|
|  | Aid To Navigation real target: ON position. |
|  | Aid To Navigation real target: OFF position. |

| Icon | Description |
|---|---|
|  | Aid To Navigation virtual target: ON position. |
|  | Aid To Navigation virtual target: OFF position. |

Standard AIS symbols are used to indicate whether the target is dangerous, lost, or selected.

Note: You can NOT display vectors for an AToN target (activate).

Note: You can NOT add an AToN target to the Buddy List.

Displaying AIS data for AToN targets

In the chart or radar application, with the AIS layer enabled:

1. Move the cursor over the relevant Aid To Navigation (AToN) target.

The softkeys change to show the AToN options.

2. Select the **VIEW FULL AIS DATA** softkey.

10.14 Land base station targets

With an AIS unit connected by NMEA 0183 or SeaTalk^{ng} your system can display land base station targets.

Land base station targets represent shore-based stations that have been equipped with AIS technology. They broadcast information such as their location, approximately every 10 seconds.

These stations may also be programmed to provide other navigation safety information, for example, meteorological and hydrological data. However, not all information broadcast by land base station targets is currently supported by your multifunction display.

The following land base station target information is supported by your multifunction display, and will be shown in the chart or radar applications when you position the cursor over a land base station target and press the **VIEW FULL AIS DATA** softkey:

- Name.
- Type.
- Position.
- Status.
- Off / On position.
- MMSI.
- Dimensions.
- CPA.
- TCPA.
- Last seen.

In the chart and radar applications land base station targets are shown as:

| Icon | Description |
|--|-----------------------------------|
|  | Land base station target: ONLINE. |

Standard AIS symbols are used to indicate whether the target is dangerous, lost, or selected.

Note: You can NOT display vectors for land base station targets (activate).

Note: You can NOT add land base station targets to the Buddy List.

Displaying AIS data for land base station targets

In the chart or radar application, with the AIS layer enabled:

1. Move the cursor over the relevant land base station target.
The softkeys change to show the options.
2. Select the **VIEW FULL AIS DATA** softkey.

Chapter 11: Using the Course Deviation Indicator

Chapter contents

- [11.1 Course Deviation Indicator overview on page 166](#)
- [11.2 Displaying the CDI application on page 167](#)
- [11.3 Using the CDI application on page 167](#)

11.1 Course Deviation Indicator overview

The Course Deviation Indicator (CDI) gives a graphical representation of your vessel's course in a 'rolling road' format.

With your display receiving accurate heading and position information, you can use the Course Deviation Indicator (CDI) to monitor your course and accurately steer to a target waypoint.

The CDI application shows a 'rolling road', which represents a width of sea equal to the Cross Track Error (XTE) limits that you have specified in the Setup menu. As you travel towards the target waypoint, the checkered pattern and the waypoint will move down the screen at a rate proportional to your boat's speed. Navigation data is displayed alongside or below the rolling road.

The CDI application is pre-configured to display the CDI graphic. You can customize the panel to display any available data.

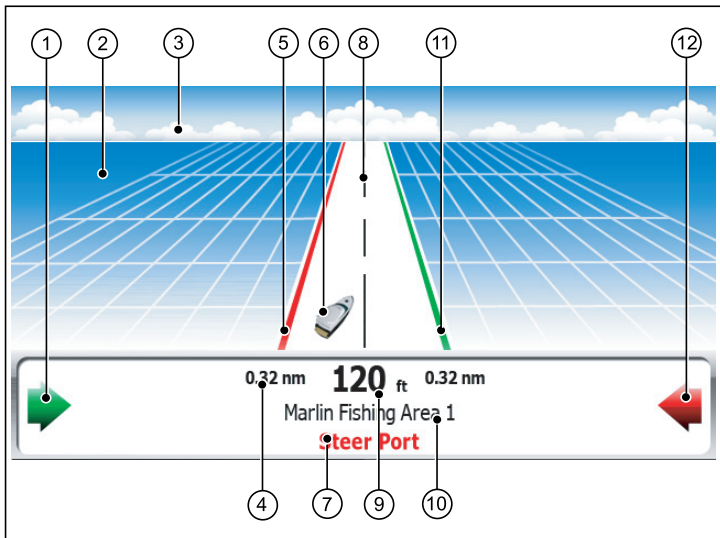

| Screen item | Description |
|-------------|---------------------------------------|
| 1 | Starboard steer arrow |
| 2 | Water |
| 3 | Horizon |
| 4 | Maximum Cross-Track Error (XTE) value |
| 5 | Port line |
| 6 | Vessel icon |
| 7 | Steer instruction |
| 8 | Center line |
| 9 | Cross-Track Error (XTE) value |
| 10 | Destination name |
| 11 | Starboard line |
| 12 | Port steer arrow |

11.2 Displaying the CDI application

With the home screen displayed:

1. Select a page that includes the CDI application.

The CDI application is displayed.

Note: If the CDI application is placed in multiple windows, the same data is displayed in each.

11.3 Using the CDI application

Monitoring Your Course Using CDI

You can use the 'rolling road' format of the Course Deviation Indicator (CDI) application to monitor your course.

The steering instructions below the rolling road tell you what correction is needed to maintain your course and arrive at the target waypoint.

The following table explains these instructions.

| Instruction | Cause |
|--------------------|--|
| STEER STARBOARD | XTE error to port is more than a 1/4 of the maximum XTE error limit in the Setup menu. |
| STEER PORT | XTE error to starboard is more than a 1/4 of the maximum XTE error limit in the Setup menu |

Indication arrows are placed either side of the steering instruction, pointing towards the centre line. The greater the error the more arrows appear. You should correct your course by steering in the direction indicated by the arrows.

Following a route using the CDI application

1. In the CDI application, press the **GOTO** softkey.
2. Press the **FOLLOW ROUTE OPTIONS** softkey.
The Route List is displayed.
3. Using the trackpad, select the route that you want to follow.
4. Press the **OK** button.

Going to a waypoint using the CDI application

1. In the CDI application, press the **GOTO** softkey.
2. Press the **GOTO WAYPOINT OPTIONS** softkey.
The Waypoint List is displayed.

3. Using the trackpad, select the waypoint that you want to go to.
4. Press the **GOTO WAYPOINT** softkey.

Note: Press the **STOP GOTO** softkey at any time to stop going towards the waypoint.

Note: If you have sailed off course while heading to a waypoint, you can press the **RESTART XTE** button at any time to restart Cross Track Error.

Changing the data displayed in the CDI application

In the CDI application:

1. Press the **MENU** button.
2. Select the **Panel Setup Menu** menu item.
3. Select the **Configure: CDI** menu item.
A red outline appears around the main screen element in the CDI display.
4. Highlight the data element that you want to change.
5. Select the **SELECT DATA** softkey.
6. Select the appropriate data group.
7. Highlight the data item that you want, then select the appropriate option.
8. Press the **OK** button.

The CDI display will be updated to show the data that you specified.

Chapter 12: Using the fishfinder

Chapter contents

- [12.1 Fishfinder introduction on page 170](#)
- [12.2 The sonar image on page 171](#)
- [12.3 Fishfinder presets on page 173](#)
- [12.4 Fishfinder display modes on page 174](#)
- [12.5 Fishfinder range on page 177](#)
- [12.6 Fishfinder presentation options on page 178](#)
- [12.7 Fishfinder waypoints on page 183](#)
- [12.8 Fishfinder alarms on page 183](#)
- [12.9 Fishfinder setup on page 184](#)

12.1 Fishfinder introduction



Warning: Sonar operation

- NEVER operate the sounder with the boat out of the water.
- NEVER touch the transducer face when the sounder is powered on.
- SWITCH OFF the sounder if divers are likely to be within 7.6 m (25 ft) of the transducer.

Fishfinder overview

The fishfinder application provides a detailed view of the fish and seabed under your vessel, enabling you to accurately distinguish between different sizes of fish, bottom structure, and underwater obstacles. The standard fishfinder image is a historical, scrolling bottom graph with range and sonar frequency automatically selected by the system.

The various functions and features of the fishfinder application include:

- Preset modes for easy optimal operation.
- Display modes (Zoom, A-Scope or Bottom Lock).
- Adjustable range and zoom.
- Finding bottom feeding fish with the **bottom lock** display mode.
- Clutter and gain options to simplify the image.
- Pausing and adjusting the speed of the scrolling image.
- Using waypoints to mark a position.
- Determining depths and distances of targets.
- Fishfinder alarms (fish, depth or water temperature).

Fishfinder screen

The fishfinder displays a scrolling image of the seabed, updating from the right as your vessel makes progress.

Example fishfinder screen

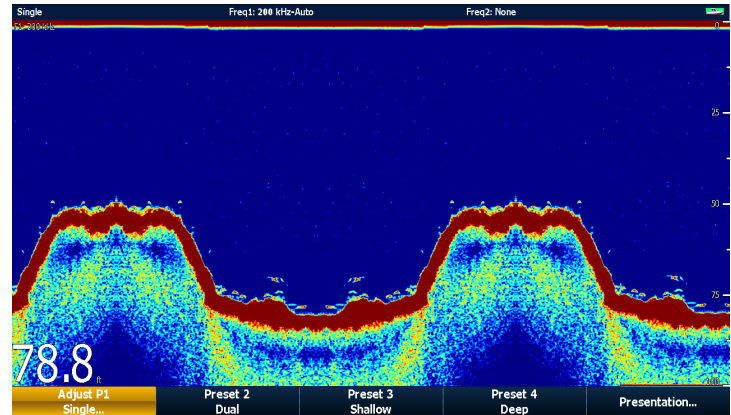

The fishfinder window includes the following aspects:

- The bottom together with any bottom structure such as reefs and shipwrecks etc.
- Target images indicating fish.
- A status bar noting the frequency and gain settings.
- The bottom depth.

Status icon

The fishfinder status icon is located in the top-right section of the screen:



- **Icon animated** - fishfinder is operating.

- **Icon static** - the fishfinder transducer is connected but not transmitting.
- **Icon greyed-out** - no fishfinder transducer is connected.

How the fishfinder works

The fishfinder application uses a Digital Sounder Module (DSM) and a suitable sonar transducer. The DSM interprets signals from the transducer and builds up a detailed underwater view.

The transducer is located on the bottom of the boat, it sends pulses of sound waves into the water and measures the time it takes for the sound wave to travel to the bottom and back. The returning echoes are affected by bottom structure and by any other objects in their path, for example reefs, wrecks, shoals or fish.

Colors are used on the display to indicate the strength of the returns. You can use this information to determine the bottom structure, the size of fish and other objects in the water, such as debris or air bubbles

Note: Some transducers include additional sensors to measure water temperature and/or speed.

12.2 The sonar image

Interpreting the seabed using sonar

It is important to understand how to correctly interpret the seabed structure represented in the fishfinder display.

The seabed usually produces a strong echo.

The following images show how different seabed conditions are represented in the sonar display:

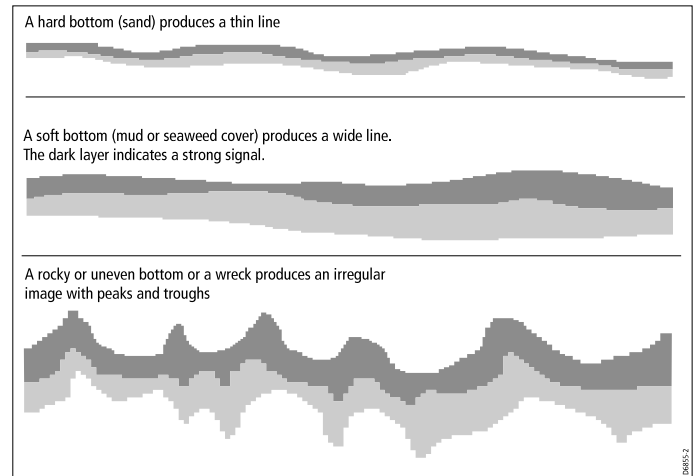

The dark layers indicate a good echo; the lighter areas indicate weaker echoes. This could mean that the upper layer is soft and therefore allowing sound waves to pass to the more solid layer below.

It is also possible that the sound waves are making two complete trips – hitting the seabed, bouncing off the vessel, then reflecting off the seabed again. This can happen if the water is shallow, the seabed is hard, or the gain is set high.

Factors influencing the sonar display

The quality and accuracy of the display can be influenced by a number of factors including vessel speed, depth, object size, background noise and transducer frequency.

Vessel speed

The shape of the target changes along with your speed. Slower speeds return flatter, more horizontal marks. Higher speeds cause the target to thicken and arch slightly, until at fast speeds the mark resembles a double vertical line.

Target depth

The closer the target to the surface, the larger the mark on screen.

Note: The depth of individual targets can be displayed by switching on the **Target Depth ID** in the fishfinder setup menu. The number of target depths displayed is influenced by the fish alarm sensitivity level.

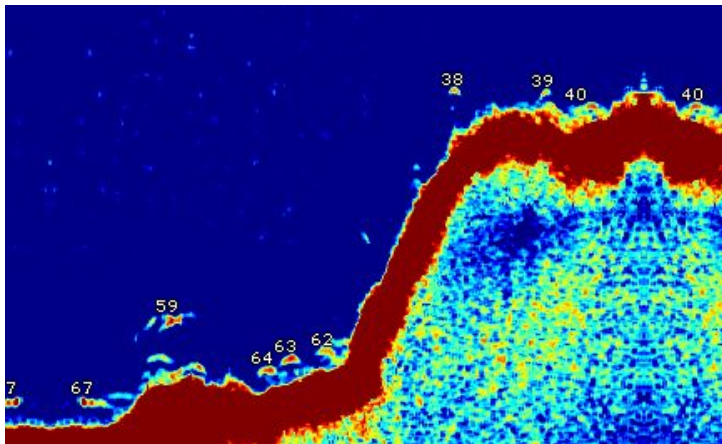

Water depth

As sea depth increases signal strength decreases, resulting in a lighter on-screen image of the bottom.

Size of the target

The larger the target, the larger the return on the fishfinder display. The size of a fish target is also dependent upon the size of the fish's swim bladder rather than its overall size. The swim bladder varies in size between different breeds of fish.

Transducer frequency

The same target will appear differently when the transducer frequency is changed. The lower the frequency the broader the mark.

Clutter / Background noise

The fishfinder picture may be impaired by echoes received from floating or submerged debris, air bubbles or even the boats movement. This is known as 'background noise' or 'clutter' and is controlled by the gain modes. The system will automatically control the gain settings according to the depth and water conditions. You can however adjust the gain settings manually if you prefer.

12.3 Fishfinder presets

The fishfinder provides you with four preset configurations available on the fishfinder toolbar. These enable you to quickly select appropriate settings tailored for various situations.

Each preset has been configured to provide the best operating parameters for the fishfinder. However, it is possible to manually adjust the presets if necessary. The four presets are:

- **Single** — this preset provides quick access to a single-frequency configuration, suitable for general fishing conditions.
- **Dual** — this preset provides a dual frequency configuration. You can either display two different frequencies at the same time in one window, or display one frequency at full-screen on your master display and the other frequency at full-screen on an additional networked display.
- **Shallow** — this preset optimizes the fishfinder display for shallow waters.
- **Deep** — this preset optimizes the fishfinder display for deep waters.

Display modes

When using presets, you can either select the relevant preset and start using the default configuration immediately, or you can adjust the preset to your needs using the display modes:

- Zoom
- Bottom Lock
- A-Scope

Any changes you make to a preset are retained when you switch off the power to your multifunction display.

Selecting a fishfinder preset

From the fishfinder main screen:

1. Press the appropriate softkey to select from:

- **PRESET 1 SINGLE**,
- **PRESET 2 DUAL**,
- **PRESET 3 SHALLOW** or
- **PRESET 4 DEEP**

After a few moments, the fishfinder display will change to the new mode. This is indicated in the top left-hand corner of the status bar.

12.4 Fishfinder display modes

Selecting a fishfinder display mode

When a fishfinder preset is selected, its softkey label changes to **ADJUST**. Pressing this softkey allows you to configure the display mode settings to suit your requirements. (Changes to the display mode are saved with the preset at power-off.)

From the fishfinder main screen:

1. Use the softkeys to select an appropriate preset.
The softkey name changes to **ADJUST...**
2. Select the **ADJUST...** softkey.
3. With dual frequency screens select **FREQ1** or **FREQ2** to select which frequency display you wish to change.
4. Select the **SELECT VIEW** softkey.
5. Select the required display mode:
 - None,
 - Zoom,
 - Bottom Lock or
 - A-Scope.

Fishfinder zoom mode

The zoom display mode magnifies a region of the fishfinder screen to display more detail.

This zoom option enables you to:

- Replace the standard fishfinder image with the zoomed image, or display the zoomed image alongside the standard fishfinder image.
- Set the zoom factor to a predefined level, or adjust it manually.
- Reposition the zoomed portion of the image to a different point in the display.

When the range increases, the area shown in the zoom window also increases.

Zoom split

With the zoom display mode you can split the screen and display the zoomed image alongside the standard fishfinder image (**ZOOM SPLIT**). The zoomed section is indicated on the standard fishfinder screen by a zoom box.

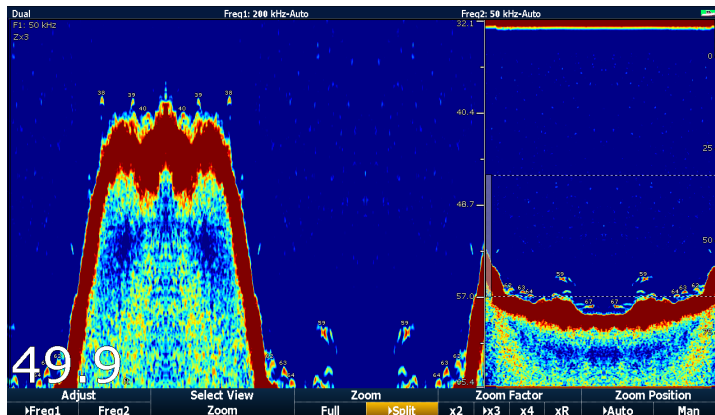

Enabling fishfinder zoom mode

From the fishfinder main screen:

1. Use the softkeys to select an appropriate preset.
The softkey name changes to **ADJUST...**
2. Select the **ADJUST...** softkey.
3. With dual frequency screens select **FREQ1** or **FREQ2** to select which frequency display you wish to change.
4. Select the **SELECT VIEW** softkey.
5. Select the **ZOOM** option.

Selecting zoom split screen

With the fishfinder in zoom mode:

1. Press the **ZOOM** softkey to select FULL or SPLIT as required.

Adjusting the fishfinder zoom factor

When the zoom function is active (ZOOM FULL or ZOOM SPLIT), you can either select a predefined zoom factor or adjust it manually.

With the fishfinder in zoom mode:

1. Press the **ZOOM FACTOR** softkey to toggle between predefined settings or select xR to set a factor manually. For manual settings, adjust the zoom factor with the trackpad.
2. Press the **OK** button.

Adjusting the position of the fishfinder zoomed area

When the zoom function is selected, the system automatically selects the zoom position so that the bottom details are always in the lower half of the display. If required you can reposition the portion of the image to be zoomed so that an alternative area is displayed.

With the fishfinder in zoom mode:

1. Press the **ZOOM POSITION** softkey until the MAN option is selected.
2. Use the rotary control to reposition the zoomed area as required.
3. Press the **OK** button.

Fishfinder A-Scope mode

The A-Scope mode enables you to view a live (rather than historical) image of the seabed and fish directly below your vessel.

The standard fishfinder display shows a historical record of fishfinder echoes. If required, you can display a live image of the bottom structure and the fish directly below the transducer by using the A-Scope feature. The width of the bottom covered by the A-Scope is indicated at the bottom of the window. A-Scope provides a more precise and easier to interpret indication of the target strength.

There are three A-Scope modes, as illustrated in the diagram below:

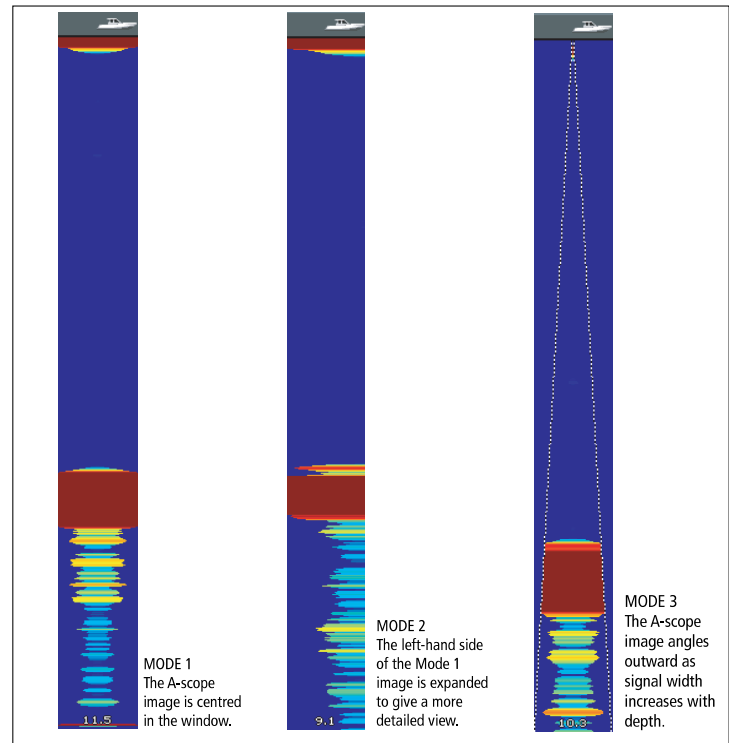

Enabling the Fishfinder A-Scope Mode

From the fishfinder main screen:

1. Use the softkeys to select an appropriate preset. The softkey name changes to **ADJUST...**
2. Select the **ADJUST...** softkey.
3. With dual frequency screens select **FREQ1** or **FREQ2** to select which frequency display you wish to change.

4. Select the **SELECT VIEW** softkey.
5. Select the A-SCOPE option.

Note: Enabling A-Scope mode automatically switches OFF Bottom Lock and Zoom.

Bottom Lock

The Bottom Lock function applies a filter to flatten the image of the seabed and make any objects on or just above it easier to discern. This feature is particularly useful for finding fish that feed close to the bottom.

Bottom Lock is selected for individual fishfinder windows and can replace or appear alongside the standard fishfinder image. Adjusting the range of the bottom lock image allows you to view more bottom details. You can also reposition the image on screen to anywhere between the bottom of the window (0%) and the middle of the window (50%) by using the Bottom Shift control.

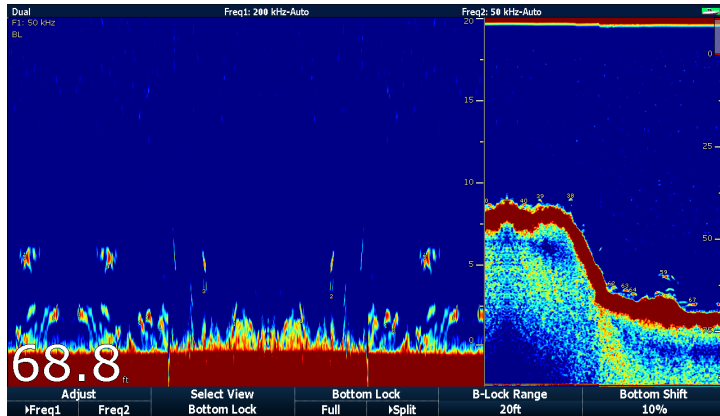

Bottom Lock is selected for individual fishfinder windows and can either replace (ON) or appear alongside (SPLIT) the standard fishfinder image.

Enabling Bottom Lock

From the fishfinder main screen:

1. Use the softkeys to select an appropriate preset.
The softkey name changes to **ADJUST...**
2. Select the **ADJUST...** softkey.
3. With dual frequency screens select **FREQ1** or **FREQ2** to select which frequency display you wish to change.
4. Select the **SELECT VIEW** softkey.
5. Select the BOTTOM LOCK option.

Adjusting the bottom lock range/position

With the fishfinder in bottom lock mode:

1. Use the appropriate softkeys and the trackpad to set Full / Split screen, Bottom lock range and Bottom shift values as appropriate.

12.5 Fishfinder range

The Range and Range Shift functions enable you to change the range of depth displayed by the fishfinder.

Range

The Range function enables you to define the range of depth that you see in the fishfinder display.

By default, the fishfinder display shows the shallowest required range, enabling you to clearly see what is near the surface of the water under your vessel. This is useful for finding smaller fish that feed nearer the surface. An example of this kind of depth range is 0 to 200 feet. In this case, the range is 200 feet, so 200 feet of water will be displayed on-screen at any one time.

There may be circumstances in which you want to see a less detailed image showing a greater amount of depth beneath your vessel. This is useful for locating bigger fish and other objects located closer to the seabed such as wrecks. An example of this kind of depth range is 0 to 1000 feet or greater. In this case, the range is 1000 feet, and you will be able to see 1000 feet of water beneath your vessel, without needing to scroll the display up or down.

Range Shift

The Range Shift function enables you to define which area of the overall depth you want to be able to see on-screen. For example, if your range is 5000 feet and the display is showing the surface (0 feet) at the very top of the display, and 5000 feet at the bottom of the display, you can use the Range Shift function to focus on a different 5000 foot range. For example, 2000 feet at the very top of the screen, and 7000 feet at the very bottom of the screen.

Example screen with range and range shift used to view the seabed at a depth range of 40–80 ft

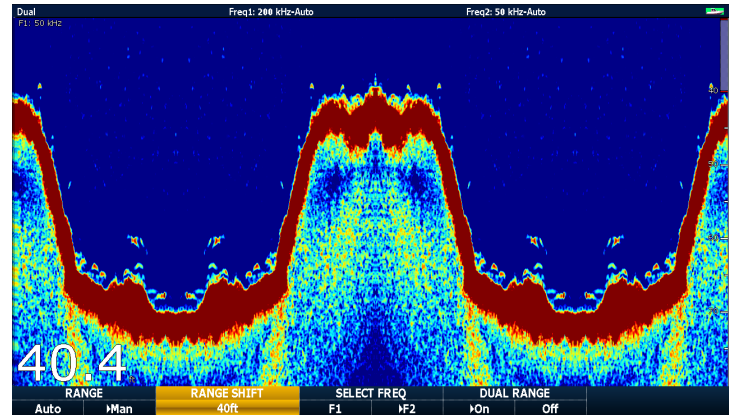

Changing the fishfinder depth range

You can choose from either:

- an **automatic** adjustment whereby the display automatically show the shallowest required range.
- **manual** adjustment of the depth range, up to the maximum depth displayed on the scrolling bottom and A-Scope images.

Changes to the range affect all fishfinder windows.

1. Press the **RANGE** button.
2. Toggle to AUTO or MAN using the **RANGE** softkey.
3. Use the rotary controller to adjust the depth range.
4. Press **OK**.

Using fishfinder range shift

The DSM automatically adjusts the display to keep the bottom in the lower half of the display window. Alternatively you can shift the image within the current range. Changes to the range shift are reflected in all fishfinder windows.

1. Press the **RANGE** control to open the range toolbar.
2. Press the **RANGE** softkey repeatedly until the MAN option is selected.
3. Press the **RANGE SHIFT** softkey.
4. Select your desired setting using the trackpad.
5. Press **OK**.

12.6 Fishfinder presentation options

The **PRESENTATION** softkey gives you access to a features and functions which enhance the fishfinder display and provide additional on-screen functionality.

Presentation options include:

- **Gain** settings to enhance display clarity.
- **Power** to the transducer.
- **VRM** features for measuring depth distance.
- Dual frequency **view** options.
- **Scroll** pause and resume.

Sonar gain

The gain settings alter the way the DSM processes background noise (also called clutter). Adjusting the gain settings can improve the sonar image, however for optimum performance in most conditions, we recommend that you use the auto settings.

The gain adjusts the return threshold (echo strength) above which the fishfinder will show an object on the screen.

There are two gain modes:

- Auto
- Manual

Auto

In Auto mode, the DSM sonar automatically adjusts the gain setting to suit current conditions. Any adjustments made apply to all fishfinder windows using that particular frequency.

There are three Auto modes, each suited to different scenarios:

- **Low (Cruising)** is ideal for viewing fishfinder images with a minimum of background noise as you are cruising to your fishing spot. Only the strongest echoes are displayed.

- **Medium (Trolling)** is a slightly higher gain setting that displays more detail. This is the default mode.
- **High (Fishing)** provides the most detail, but also displays the most background noise and surface clutter.

Manual

If necessary you can set the gain controls manually, between a value of 1 to 100 (default value is 75). This value should be set high enough to see fish and bottom detail but without too much background noise. Generally a high gain is used in deep and/or clear water; a low gain in shallow and/or murky water.

The new values remain set even when you switch off the display, they are applied to both the active window and any other fishfinder windows with the same frequency.

Selecting automatic fishfinder gain

From the main fishfinder screen:

1. Press the **PRESENTATION** softkey.
2. Press the **GAIN** softkey.
3. Press the **GAIN** softkey until the AUTO option is selected.
4. Use the trackpad to select the auto mode you want.
5. Press the **OK** button.

Adjusting the fishfinder gain manually

From the main fishfinder screen:

1. Press the **PRESENTATION** softkey.
2. Press the **GAIN** softkey.
3. Press the **GAIN** softkey until the MAN option is selected.
4. Use the rotary control to select the amount of gain you want, between a value of 1 to 100. (The default value is 75).
5. Press the **OK** button.

The new values remain set even when you switch off the display, they are applied to both the active window and any other fishfinder windows displaying the same frequency.

Fishfinder color gain

You can adjust the color gain to change the signal strength threshold for the strongest color in your fishfinder display.

Color gain sets the lower limit for the strongest echo color. All echoes with a signal strength above this value are displayed in the strongest color. Those with a weaker value are divided equally between the remaining colors.

- Setting a low value produces wide band for the weakest color, but a small signal band for the other colors.
- Setting a high value gives a wide band for the strongest color, but a small signal band for the other colors.

There are two color gain modes:

- **Auto.** In Auto mode the color gain setting is automatically adjusted to suit current conditions. Any adjustments made apply to all fishfinder windows.
- **Manual.** You can set the color gain manually, between a value of 1 to 100.

Adjusting the fishfinder color gain

From the main fishfinder screen:

1. Press the **PRESENTATION** softkey.
2. Press the **GAIN** softkey.
3. Press the **COLOR GAIN** softkey until the MAN option is selected.
4. Use the rotary control to select the amount of color gain you want.
5. Press the **OK** button.

The new values remain set even when you switch off the display and are applied to all fishfinder windows.

Fishfinder color threshold

The color threshold setting determines the range of colors used on screen. The effect of this is to set a color threshold below which targets are not shown. For example a low setting would result in only the strongest (orange and red) targets being displayed.

Adjusting the fishfinder color threshold

From the main fishfinder screen:

1. Press the **PRESENTATION** softkey.
2. Press the **GAIN** softkey.
3. Press the **COLOR THRESHOLD** softkey.
4. Use the rotary controller to select the required color threshold.
5. Press the **OK** button.

Fishfinder TVG (Time Varied Gain)

The Time Varied Gain (TVG) function reduces the amount of clutter in the fishfinder display by varying the gain throughout the column of water. This function is useful for reducing the appearance of 'noise'.

- Increasing the TVG value increases the maximum depth to which TVG is applied. A high value decreases the gain in shallow water so that only the strongest echoes are displayed.
- Decreasing the TVG value reduces the maximum depth. A low TVG value has little effect on gain in shallow water.

TVG adjustment can be made automatically or manually.

Adjusting the fishfinder time varied gain

Note: TVG has no effect in fishfinder simulator mode.

1. From the main fishfinder screen, press the **PRESENTATION** softkey.
2. Press the **GAIN** softkey.
3. Press the **TVG** softkey until the MAN option is selected.

4. Use the rotary control to select the amount of Time Varied Gain you want.
5. Press the **OK** button.

Fishfinder power

The power setting controls the power level of the transducer.

Power options:

- **Auto.** This is the default setting. When it is selected the DSM automatically determines the required power setting based on the current depth, speed, and (bottom) signal strength. .
- **Manual.** If you wish to manually adjust the power to suit current conditions, you can adjust the power level between 0% and 100%, in 10% increments. Lower power levels are normally used in depth ranges less than 8 ft. (2.4 m) and higher power levels are typically selected for depths greater than 12 ft. (3.7 m).

Adjusting the fishfinder power

From the main fishfinder screen:

1. Press the **PRESENTATION** softkey.
2. Press the **POWER** softkey until the MAN option is selected.
3. Use the rotary control to select the amount of power you want.
4. Press the **OK** button.

The new values remain set even when you switch off the display and are applied to all fishfinder windows.

Depth and distance with the fishfinder

You can use VRM markers and depth lines to help you determine depths and distances in the fishfinder display.

The fishfinder display provides a number of features to help you determine depths and distances. These features are illustrated and described in more detail below:

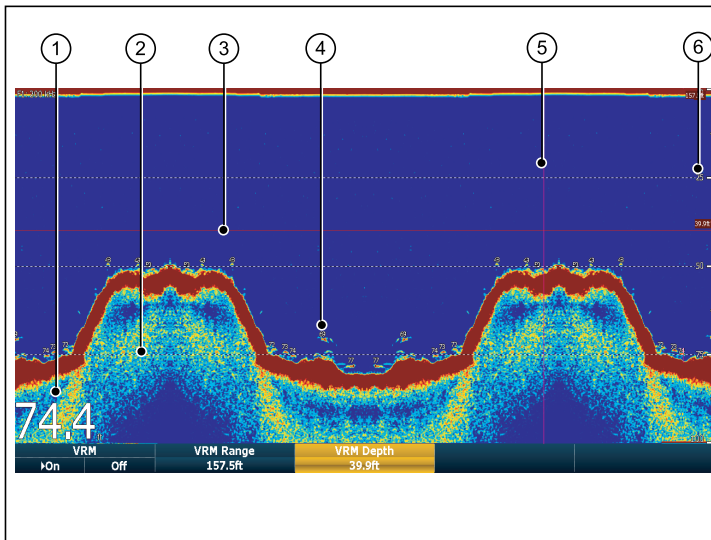

| Screen item | Description |
|-------------|--|
| 4 | Depth Target ID — depths are displayed against recognized targets. The sensitivity of these IDs is directly linked to the Fish Alarm sensitivity; the greater the fish alarm sensitivity, the greater the number of labelled returns. These targets are switched on or off using the Fishfinder Display Setup menu. |
| 5 | Vertical VRM marker — indicates the distance behind your vessel. |
| 6 | Depth markers — these numbers indicate the depth. |

Measuring depth and distance with VRM

You can use a Variable Range Marker (VRM) to determine an object's depth and distance behind your vessel. These markers consist of a horizontal (depth) line and a vertical (distance) line, each of which are marked with the appropriate measurement and are controlled individually.

From the main fishfinder screen:

1. Press the **PRESENTATION** softkey.
2. Press the **SCROLL** softkey to pause the display. This may make it easier to position the VRM over the desired object.
3. Press the **VRM** softkey to open the VRM toolbar.
4. Press the **VRM** softkey again until the ON option is selected.
5. Measure the depth or distance:
 - Press the **VRM RANGE** softkey to measure distance, or
 - Press the **VRM DEPTH** softkey to measure depth.
6. Use the rotary control or touchscreen to measure the distance or depth to your target.
7. Press the **OK** button to save the position.

Note: The VRMs used in the fishfinder application are unrelated to the VRMs used in the radar application.

| Screen item | Description |
|-------------|--|
| 1 | Depth reading — your current depth displayed. The size and position of this digit can be changed, using the Fishfinder Display Setup menu. |
| 2 | Depth lines — horizontal dashed lines drawn at regular intervals to indicate the depth from the surface. These lines can be switched on or off using the Fishfinder Display Setup menu. |
| 3 | Horizontal VRM marker — indicates the depth of a target. |

Measuring depth and distance using touch

From the main fishfinder screen:

1. Select the **PRESENTATION** softkey.
2. You may find it helpful to use the **SCROLL** softkey to pause the display.
3. Select the **VRM** softkey.
4. Touch the screen at the position where you want to measure the depth or distance.

The distance is displayed on the vertical axis, and the depth on the horizontal axis.

Fishfinder scrolling

The fishfinder image scrolls from right to left. You can adjust or pause the scrolling, for example to ease placing of waypoints or VRMs on-screen.

Scroll speed

You can adjust the speed at which the fishfinder image scrolls. A faster speed provides more detail which may be useful when you are looking for fish. If you select a slower speed the information remains on the display for longer.

The following option is available:

- **Manual.** This allows you to set the scroll speed as a percentage of the maximum scroll rate for that depth. The lower the percentage, the slower the image will scroll. The default setting is 100%.

Scroll pause

You can pause the display to see a 'snapshot' of the fishfinder image. When the image is paused scrolling stops but the depth indication continues to be updated. Scroll pause/resume affects the currently selected fishfinder frequency.

If you are in dual frequency mode, you can pause one frequency while the other continues to scroll. This allows you to inspect a paused image while the other frequency continues to scroll and detect fish.

Note: Scrolling will resume if the frequency changes. For example an automatic change of frequency resulting from a change in depth.

Adjusting the fishfinder scrolling speed

From the fishfinder screen:

1. Press the **MENU** button.
2. Select the **Fishfinder Setup** menu item.
3. Select Manual Scroll Speed .
4. Use the rotary control to adjust the scroll speed to the required value.

Pausing the fishfinder scrolling image

From the main fishfinder screen:

1. Press the **PRESENTATION** softkey.
2. Press the **SCROLL** softkey to pause the display.
3. Press the **OK** button.

Dual / Single frequency fishfinder

Dual frequency operation allows the sonar to operate and display 2 frequencies simultaneously. If the preset mode that you are using has two frequencies, you can view either one or both of those frequencies in separate windows.

Selecting dual frequency view

From the main fishfinder screen:

1. Select the **PRESET 2 DUAL** softkey.
2. Select the **PRESENTATION** softkey.
3. Use the **VIEW** softkey to switch between the available views.

12.7 Fishfinder waypoints

Placing a waypoint on the fishfinder display enables you to mark a position that you can return to later.

When a waypoint is placed, its details are added to the waypoint list and a vertical line labelled WPT is displayed on screen. You can edit waypoints and navigate to them in the fishfinder window.

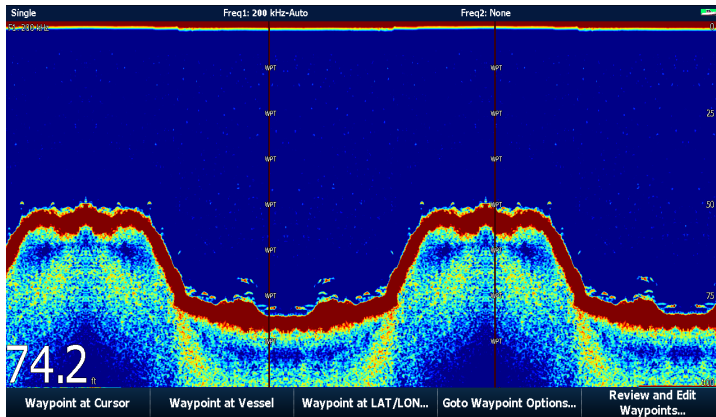

Placing a Waypoint on the Fishfinder Display

With the fishfinder screen active:

1. Press the **WPTS/MOB** button.
2. Select the appropriate option: **WAYPOINT AT CURSOR** , **WAYPOINT AT VESSEL**, or **WAYPOINT AT LAT/LON**.

12.8 Fishfinder alarms

The display can be configured to provide a number of fishfinder alarms.

The following fishfinder alarms can be set when you are connected to a DSM, or when the simulator is on:

- **Fish alarms** sound when a target meets the specified sensitivity level and, is within the depth limits (if enabled). The greater the fish alarm sensitivity, the greater the number of target image depths displayed.
- **Shallow/Deep alarms** sound when the DSM detects that the depth is less than the shallow limit, or greater than the deep limit.

Setting up fishfinder alarms

Fishfinder alarms are configured within the alarms set up menu.

1. Press the **MENU** button.
2. Select the **Alarm Setup** menu item.
3. Select **Fishfinder Alarms Setup** .
4. Use the menu items to make the required changes.
5. Press the **OK** button to save the changes.

12.9 Fishfinder setup

Opening the fishfinder setup menu

In the fishfinder application:

1. Press the **MENU** button.
2. Select the **Fishfinder Setup** menu item.

Fishfinder setup menu options

This section describes the settings you can change using the fishfinder setup menu. The setup menu contains settings that are likely to be changed infrequently.

| Menu Item | Description | Options |
|-------------------------------------|---|--|
| Configure Preset Frequencies | Enables you to adjust the frequencies used for the four fishfinder presets. For each preset, you can select AUTO for fully automatic selection, or you can manually specify the frequency. You can also reset all the preset frequencies to the factory defaults if required. | AUTO or manual frequencies. |
| Depth Digit Size | Size of the digit that indicates the depth. | <ul style="list-style-type: none">• Small• Medium• Large |
| Depth Digit Position | Position of the digit that indicates the depth. | <ul style="list-style-type: none">• Bottom• Top |
| Target Depth ID | Controls whether the depth of identified targets are displayed. The level of targets displayed is directly linked to the level of Fish Alarm sensitivity. | <ul style="list-style-type: none">• On• Off |
| Depth Lines | Controls whether horizontal lines indicating depth are displayed. | <ul style="list-style-type: none">• On• Off |
| White Line | When set to ON, this option displays a white line along the contour of the sea bottom. This helps to distinguish objects close to the sea bed. | <ul style="list-style-type: none">• On• Off |
| Bottom Fill | When set to ON, this option displays a solid color fill for the sea bottom. | <ul style="list-style-type: none">• On• Off |

| Menu Item | Description | Options |
|----------------------------|--|---|
| Color Palette | Various color palettes are available to suit different conditions and your personal preferences. | <ul style="list-style-type: none"> • Classic Blue • Classic Black • Classic White • Sunburst • Greyscale • Inverted Greyscale • Copper • Night Vision |
| Manual Scroll Speed | Specify the fishfinder scroll speed. | 10 to 100% |

Fishfinder preset configuration

Sonar frequency

The frequency of the sonar determines the width of the sonar beam, the depth to which the signals will penetrate and the resolution of the image. Each of the preset operating modes has its own frequency settings.

The frequencies supported depend upon the DSM and transducer connected to your system.

- **Lower frequencies** (e.g. 50 kHz) produce a wide sonar beam and penetrate the water well. A lower frequency provides a lower resolution image that may not be as good at detecting small fish. Use lower frequencies if you require a large coverage beneath your boat or if you are in deep water.
- **Higher frequencies** (e.g. 200 kHz) produce narrow beam and produce a high resolution image. They are most useful in shallower water (up to 1000 ft) and at higher speeds.

- **Auto.** When operating in automatic frequency the system will set and adjust the frequency automatically to suit your transducer and operating conditions.

Dual operation

For dual frequency operation you can set Frequency 2 for the required preset operating modes.

Setting the fishfinder frequency

With the configure presets frequencies options you can:

- Specify one or two frequencies for each of the four presets.
 - Edit preset names.
 - Reset presets to factory defaults.
1. From the main fishfinder screen, press the **MENU** button.
 2. Select **Fishfinder Setup** from the list of options.
 3. Select **Configure Preset Frequencies** from the list of options.
 4. Make the required changes for each preset mode (P1 to P4)

Changing fishfinder preset names

1. From the main fishfinder screen, press the **MENU** button.
2. Select **Fishfinder Setup** from the list of options.
3. Select **Configure Preset Frequencies** from the list of options.
4. Use the trackpad to select the required preset.
5. Press the **EDIT NAME** softkey
6. Use the rotary control and trackpad to change the name
7. Press **OK** when complete.

Transducer and DSM settings

Selecting the DSM and transducer settings

From the main fishfinder screen:

1. Press the **MENU** button.
2. Select **Fishfinder Setup** from the list of options.
3. Select from the list of menu options:
 - Transducer Settings
 - DSM Settings

Fishfinder DSM Setup Menu Options

Nearby vessels equipped with a fishfinder, or certain physical conditions (like hard seabeds), can affect the DSM. Its setup menus enable you to change settings to allow for this.

| Menu Item | Description | Options |
|--|---|---------------------------------------|
| DSM Reset | Restore all settings on the DSM to factory default. When performing a DSM Reset, it is normal to briefly lose connection with the DSM. | Yes, No |
| Trip Counter Reset | Resets the Trip Counter of the DSM. | Yes, No |
| SONAR Interference Rejection | Removes spikes caused by other fishfinder-equipped vessels. | Auto, Low, Medium, High |
| 2nd Echo Interference Rejection | Adjusts the ping rate in small increments, according to the 2nd echo level. This results in better sensitivity of the image. | Off, Low, High |
| Ping Rate Limit (per second) | Provides a speed limiter; it is useful to adjust the ping rate to suit local conditions. For example, the ping rate may be too fast when there is a hard bottom in shallow water. This setting reverts to 26 pings per second when the DSM unit is powered off. | 5 to 30 pings per second (30 default) |
| Ping Enable | The sonar ping is normally enabled. It can be disabled. This is useful when other equipment is being tested, or if someone is diving beneath the boat. This setting reverts to Enabled when the DSM unit is powered off. | Disabled, Enabled |

Fishfinder Transducer Calibration

Your fishfinder transducer must be calibrated correctly to achieve accurate depth readings.

The multifunction display receives the image from a DSM which processes sonar signals from a transducer mounted in the water. If the transducer is equipped with a speed paddle wheel and temperature-sensing thermistor, the DSM calculates speed and temperature. To ensure accurate readings, it may be necessary to calibrate the transducer(s) by applying offsets to depth, speed and temperature. As these settings are held in the DSM and relate to the transducer, they are applied system-wide.

Fishfinder transducer settings

| Menu Item | Description | Options |
|--------------------------------|--|---|
| Select Transducer | Select the appropriate transducer type from those displayed. | <ul style="list-style-type: none">• B256/M256• B260/M260/SS560• R99/R199• B258• SS270/B264• B164• R209/R299 |
| Select Speed Transducer | Select the appropriate speed transducer from those available. This option is only available if you are not using a combined Depth/Speed or Depth/Speed/Temperature transducer. | <ul style="list-style-type: none">• NONE• UNKNOWN• B120/P120 ST600• ST69• B120/P120 ST800• CS4500 |

| Menu Item | Description | Options |
|---------------------------------|--|--|
| Frequency Calibration | Fine tune the frequency of the transducer. | Variable setting for the selected frequency. |
| Depth Offset (waterline) | Offset represents the depth of the transducer (relative to the waterline). | -9.9 to +9.9 feet |
| Speed Offset | Offset applied to the speed log. | 0 to 100% |
| Temperature Offset | Offset applied to the temperature transducer value. | -9.9 to +9.9 °F |

Chapter 13: Using the engine application

Chapter contents

- [13.1 Engine application overview on page 192](#)
- [13.2 Displaying the engine application on page 192](#)
- [13.3 Setting up the engine application on page 193](#)
- [13.4 Changing the engine panel dial color on page 193](#)
- [13.5 Pre-configured data panels on page 194](#)
- [13.6 Changing what the engine application displays on page 196](#)

13.1 Engine application overview

The engine application enables you to view key engine data in your multifunction display.

The engine application enables you to view information in the form of gauges and digital data, from up to three compatible engines. To provide a fast update rate, the engine data is transferred from the engine's serial interface to your multifunction display via NMEA2000/SeaTalk2.

If the default range of data shown by the engine application is not suitable, you can change what is displayed.

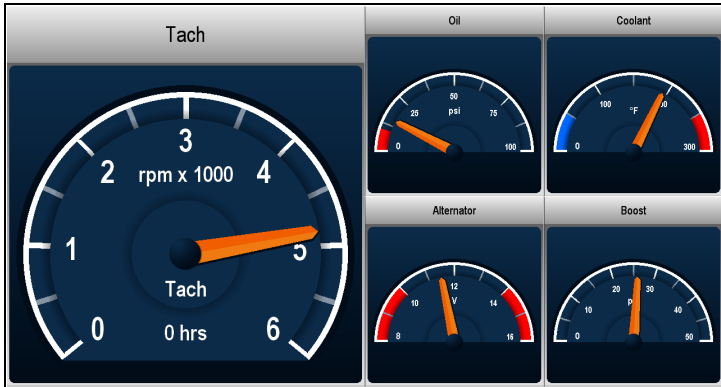

Note: For details of compatible engines and related software updates, please refer to the Raymarine website at www.raymarine.com.

13.2 Displaying the engine application

With the home screen displayed:

1. Select a page that includes the engine monitor application.
The engine monitor application is displayed.

13.3 Setting up the engine application

In the engine application:

1. Press the **MENU** button.
2. Select **Panel Setup Menu** .
3. Select **Number of Engines** , then select the appropriate value.
4. Select the **Maximum tachometer range** menu item, then select the appropriate value.

13.4 Changing the engine panel dial color

In the Engine application:

1. Press the **MENU** button.
2. Select **Panel Setup Menu**.
3. Use the **Engine Panel Dials** menu item to select the Light Background or Dark Background option, as appropriate.

13.5 Pre-configured data panels

By default, a pre-configured range of data is displayed in a number of data 'panels'. Each panel consists of a number of 'cells', each containing a different item of data.

Note: Panel selection is a local setting, and therefore only affects the individual display that you are currently using. It does not affect any networked displays.

List of pre-configured engine panels

A range of pre-configured panels show commonly used data.

The following table shows the data displayed by each type of panel. Each data item listed in the table below represents a 'cell'.

Note: Panel selection is a local setting, and therefore only affects the individual display that you are currently using. It does not affect any networked displays.

| Data | Engine | Engine and fuel | Fuel resources | Engine and resources | Twin engines |
|----------------------------|--------|-----------------|----------------|----------------------|--------------|
| Tacho and engine hours | ✓ | ✓ | ✗ | ✓ | ✓ |
| Oil pressure | ✓ | ✓ | ✗ | ✓ | ✓ |
| Engine coolant temperature | ✓ | ✓ | ✗ | ✓ | ✓ |
| Boost pressure | ✓ | ✓ | ✗ | ✓ | ✓ |
| Alternator | ✓ | ✓ | ✗ | ✓ | ✓ |
| Fuel level (tanks 1, 2, 3) | ✗ | ✓ | ✓ | ✓ | ✗ |
| Total fuel | ✗ | ✗ | ✓ | ✓ | ✗ |
| Load | ✗ | ✗ | ✓ | ✓ | ✗ |

Selecting a pre-configured data panel

In the data or engine application:

1. Using the softkeys, select the pre-configured data panel you want to use.

13.6 Changing what the engine application displays

In the engine application:

1. Press the **MENU** button.
2. Select **Panel Setup Menu** .
3. Select the appropriate **Configure:** menu item.
A red outline appears around the main data element in the engine monitoring application.
4. Highlight the data element that you want to change.
5. Select the **SELECT DATA** softkey.
6. Select the appropriate data group.
7. Select the appropriate category, then select the appropriate option.

The engine display will be updated to show the data that you specified.

Note: You can also access the **SELECT DATA** softkey by pressing and holding the physical softkey associated with the data panel you want to customize (for example, **NAVIGATION**).

Renaming data panels

In the data or engine application:

1. Press the **MENU** button.
2. Select **Panel Setup Menu**.
3. Select the panel you want to rename (Configure...).
4. Select the **RENAME PANEL** softkey.
The on-screen keyboard is displayed.
5. Enter the new name for the data panel.
6. Select the on-screen keyboard's **SAVE** key.

Changing the size of data panels

In the data or engine application:

1. Press the **MENU** button.
2. Select **Panel Setup Menu**.
3. Select the data panel you want to resize (Configure...).
4. Select the **MERGE CELLS** softkey if you want to merge the contents of the cell with an adjacent cell, resulting in a bigger cell.
5. Select the **SPLIT CELL** softkey if you want to split the size of the cell in half.

Chapter 14: Using the data application

Chapter contents

- [14.1 Data application overview on page 198](#)
- [14.2 Pre-configured data panels on page 199](#)
- [14.3 Trim tab calibration on page 202](#)
- [14.4 Customizing the data application on page 202](#)

14.1 Data application overview

The data application displays system and instrument data on your multifunction display.

The data application enables you to view numeric data generated by the system. It also shows data from instruments connected to your multifunction display using the NMEA or SeaTalk protocols.

| Ves Pos | Cog Sog | Heading | Speed |
|-----------------|----------------|----------------------------------|----------------------------------|
| 25°47'.713 N | 065 °T | 061 °T | 19.1 kt |
| 080°07'.684 W | 18.5 kt | Waypoint TTG 00h10m06s | VMG Wpt 18.4 kt |
| Waypoint 1 | Set Drift | Depth | XTE |
| 061 °T | 187 °T | 73.7 ft | 61 ft |
| 3.105 nm | 1.2 kt | Trip 3.341 nm | Local Time 12:12:40 AM |

14.2 Pre-configured data panels

By default, a pre-configured range of data is displayed in a number of data 'panels'. Each panel consists of a number of 'cells', each containing a different item of data.

Note: Panel selection is a local setting, and therefore only affects the individual display that you are currently using. It does not affect any networked displays.

List of pre-configured data panels

A range of pre-configured panels show commonly used data.

The following table shows the data displayed by each type of panel. Each data item listed in the table below represents a 'cell'.

Note: Panel selection is a local setting, and therefore only affects the individual display that you are currently using. It does not affect any networked displays.

| Data | Navigation panel | Waypoint panel | Route panel | Fishing panel | Sailing panel |
|-----------------|------------------|----------------|-------------|---------------|---------------|
| Vessel Position | ✓ | ✓ | ✓ | ✓ | ✗ |
| Active Waypoint | ✓ | ✓ | ✓ | ✓ | ✗ |
| TTG | ✓ | ✗ | ✗ | ✗ | ✗ |
| VMG — Waypoint | ✓ | ✗ | ✗ | ✗ | ✓ |
| Depth | ✓ | ✗ | ✓ | ✓ | ✗ |
| COG / SOG | ✓ | ✓ | ✓ | ✓ | ✓ |
| Heading | ✓ | ✗ | ✓ | ✓ | ✓ |
| Speed | ✓ | ✗ | ✗ | ✓ | ✓ |
| Set / Drift | ✓ | ✗ | ✗ | ✓ | ✗ |
| XTE | ✓ | ✓ | ✓ | ✗ | ✗ |
| Trip | ✓ | ✗ | ✗ | ✗ | ✗ |

| Data | Navigation panel | Waypoint panel | Route panel | Fishing panel | Sailing panel |
|-----------------|------------------|----------------|-------------|---------------|---------------|
| Local Time | ✓ | ✗ | ✗ | ✗ | ✗ |
| Sea Temperature | ✗ | ✗ | ✗ | ✓ | ✗ |
| Ground Wind | ✗ | ✗ | ✗ | ✗ | ✓ |
| App Wind | ✗ | ✗ | ✗ | ✗ | ✓ |
| True Wind | ✗ | ✗ | ✗ | ✗ | ✓ |
| VMG Wind | ✗ | ✗ | ✗ | ✗ | ✓ |

Selecting a pre-configured data panel

In the data or engine application:

1. Using the softkeys, select the pre-configured data panel you want to use.

14.3 Trim tab calibration

You can calibrate your trim tabs from your multifunction display.

Trim tab data can be displayed in the Engine, Data, and CDI applications by selecting it from the Engine Data Group, using the Panel Setup Menu.

To ensure that accurate data is displayed, you must calibrate your trim tabs. The calibration option is available in the Panel Setup Menu.

Calibrating trim tabs

In the Engine, Data, or CDI application, and your physical trim tabs accessible to you:

1. Press the **MENU** button on your multifunction display.
2. Select **Panel Setup Menu**.
3. Select **Calibrate Trim Tabs**.

The Trim Tab Calibration dialog is displayed.

Note: The **Calibrate Trim Tabs** menu item is NOT available if the **Trim Tabs** menu item shows “Not Detected”.

4. Set both physical Trim Tabs in the UP position.
5. Press the **OK** button on your multifunction display.
6. Set both physical Trim Tabs in the DOWN position, simultaneously.
7. Wait for the Calibration Complete message.
8. Press the **OK** button.

14.4 Customizing the data application

You can customize the data application to show the system and instrument data that you require.

In addition to displaying the default, pre-configured data panels in the data application, you can also customize the data panels to your specific requirements.

You can customize each data panel by changing:

- The panel name.
- The size and number of data panels.
- The data contained in each data panel. This data can include any transducer or internally calculated navigation data that is available on NMEA or SeaTalk. Additional data includes a compass rose, a distance log, and four resettable trip counters.
- How the data is displayed. You can control whether the data is displayed in numerals, digits, gauge, or graphical format, as appropriate for each data item.

Selecting customized data in the data application

In the data application:

1. Press the **MENU** button.
2. Select **Panel Setup Menu**.
3. Select the appropriate **Configure:** menu item.
A red outline appears around the main data element in the data application.
4. Highlight the data element that you want to change.
5. Select the **SELECT DATA** softkey.
6. Select the appropriate menu items to choose the Data Group and Data that you want to see in the cell you selected.
7. Select the appropriate menu items to choose the relevant data type for that particular data.

Note: You can also access the **SELECT DATA** softkey by pressing and holding the physical softkey associated with the data panel you want to customize (for example, **NAVIGATION**).

Renaming data panels

In the data or engine application:

1. Press the **MENU** button.
2. Select **Panel Setup Menu**.
3. Select the panel you want to rename (Configure...).
4. Select the **RENAME PANEL** softkey.
The on-screen keyboard is displayed.
5. Enter the new name for the data panel.
6. Select the on-screen keyboard's **SAVE** key.

Changing the size of data panels

In the data or engine application:

1. Press the **MENU** button.
2. Select **Panel Setup Menu**.
3. Select the data panel you want to resize (Configure...).
4. Select the **MERGE CELLS** softkey if you want to merge the contents of the cell with an adjacent cell, resulting in a bigger cell.
5. Select the **SPLIT CELL** softkey if you want to split the size of the cell in half.

Chapter 15: Using the weather application (North America only)

Chapter contents

- [15.1 Weather application overview on page 206](#)
- [15.2 Displaying the weather application on page 206](#)
- [15.3 Weather application setup on page 207](#)
- [15.4 Weather application display overview on page 207](#)
- [15.5 Weather map navigation on page 211](#)
- [15.6 Weather reports on page 211](#)
- [15.7 Storm tracking on page 212](#)
- [15.8 Animated weather graphics on page 213](#)

15.1 Weather application overview

The weather application overlays historical, live, and forecasted weather graphics on a world map.

The weather application can only be used in North America and its coastal waters.

The weather application graphics and their associated weather data enable you to determine the actual conditions in the vicinity of your vessel, or at a particular location.

Weather forecasts and warnings, detailing both current and predicted conditions, are regularly updated in the weather application.

Note: For types of warnings, watches, and advisories, refer to the NOAA website at www.nws.noaa.gov

Disclaimer — advisory only

The weather information is subject to service interruptions and may contain errors or inaccuracies and consequently should not be relied upon exclusively. You are urged to check alternate weather information sources prior to making safety related decisions. You acknowledge and agree that you shall be solely responsible for use of the information and all decisions taken with respect thereto. By using this service, you release and waive any claims against Sirius Satellite Radio Inc., WSI, Navcast Incorporated, and Raymarine with regard to this service.

If you do not have the subscription agreement, you may view a copy on the internet at www.sirius.com/marineweather

15.2 Displaying the weather application

With the home screen displayed:

1. Select a page that includes the weather application.
The weather application is displayed.

15.3 Weather application setup

A number of steps must be completed before you can use the weather application for the first time.

- Obtain a Sirius ID number, by contacting Sirius and subscribing to a weather and/or audio service package. Before subscribing, you must first record your data and/or audio Electronic Serial Number (ESN). This number is located on the weather receiver shipping carton, or on the back of the weather receiver itself. For more information, refer to www.sirius.com.
- Your multifunction display must be connected to a Raymarine SR100 Sirius weather receiver.
- You must be navigating within US coastal waters.
- The weather application must be added to at least one page on the home screen.
- You must specify the weather graphics that you want to display on the weather map.

Selecting weather graphics

In the weather application:

1. Press the **DISPLAY GRAPHICS** softkey.
2. Using the trackpad, select the ON option for each graphic that you want displayed on the weather map.
3. Press the **OK** button.

15.4 Weather application display overview

The weather application displays a range of graphics to indicate weather conditions and forecast information.

The following diagram illustrates the main features of the weather application display:

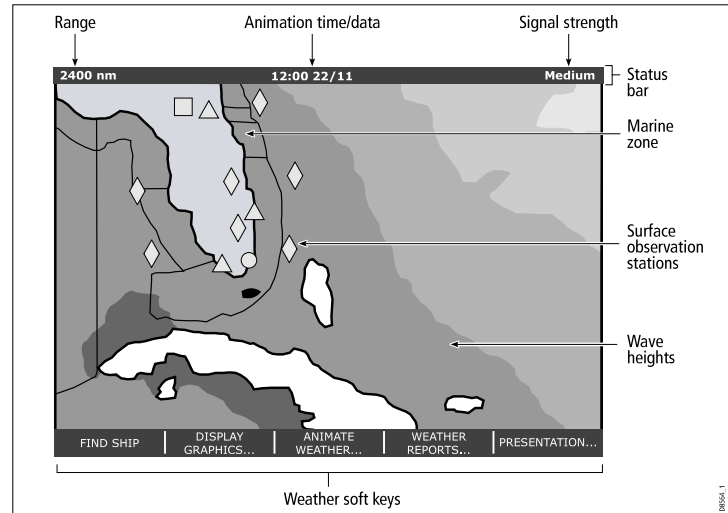

When you move the cursor over the graphics in the display, additional information is shown. The type of graphics that appear in the display are described in the following sections.

Weather symbols

The weather application uses a range of symbols to represent different weather conditions and forecasts.

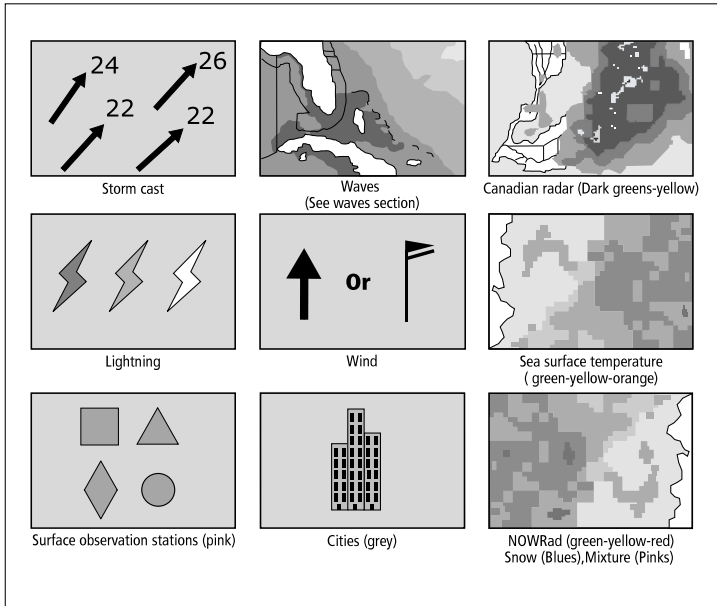

Storm tracks symbols

The weather application uses a range of symbols to represent different types of storm tracks.

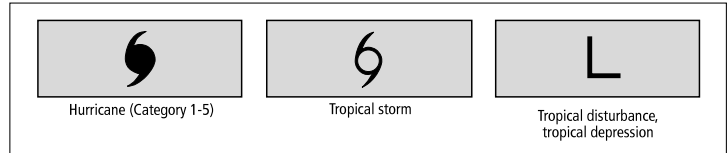

Surface pressure symbols

The weather application uses a range of symbols to represent different surface pressure conditions.

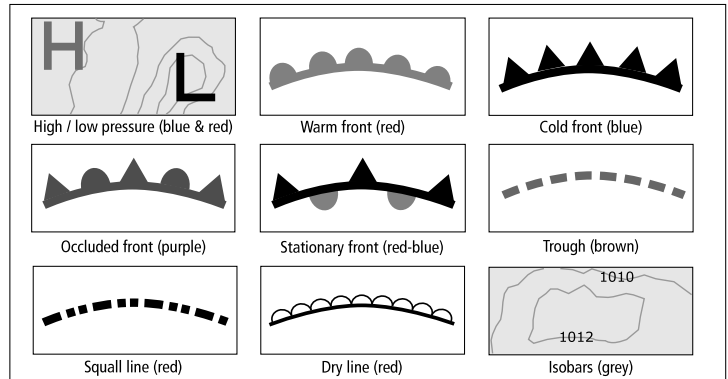

Surface observation station symbols

The weather application uses a range of symbols to represent different types of surface observation station.

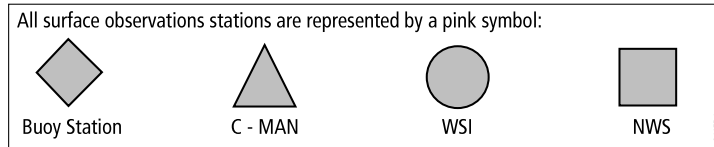

Wind speed symbols

The weather application uses a range of symbols to represent different wind speeds.

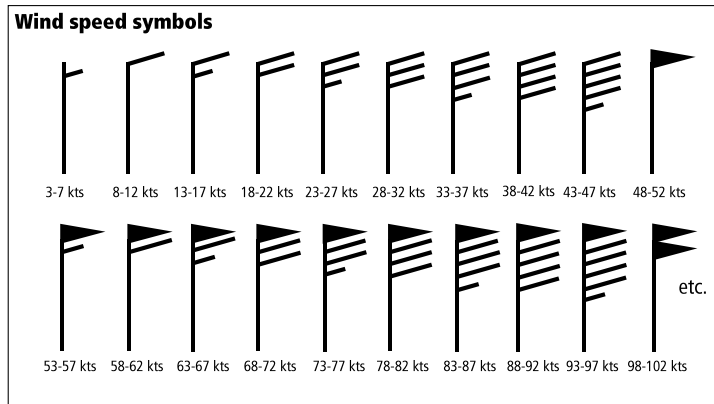

Wave information symbols

The weather application uses a range of symbols to represent different types of wave information.

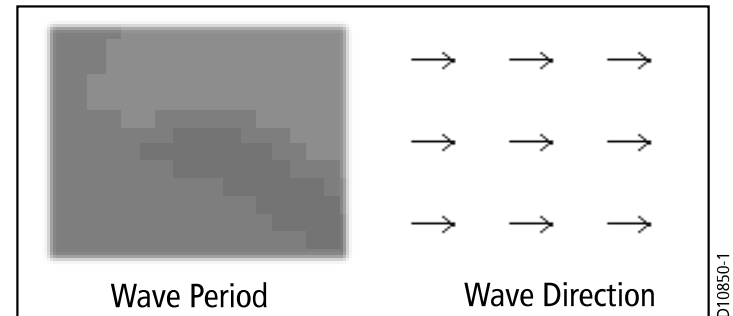
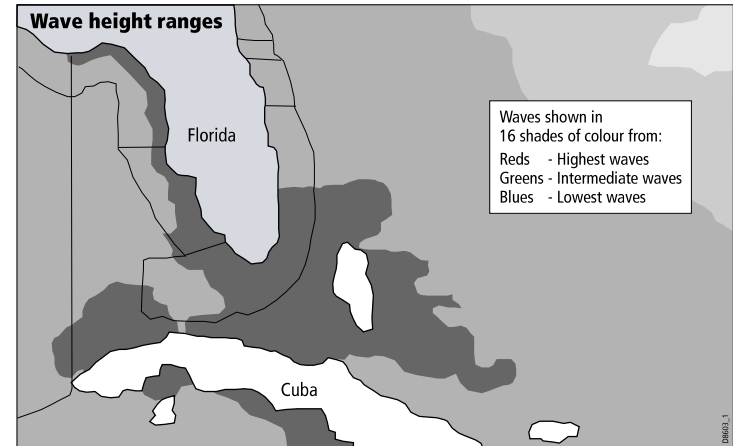

NOWRad precipitation color codes

NOWRad displays the type and level of precipitation:

| Color code | Precipitation type | Intensity |
|--------------|--------------------|----------------|
| Light green | Rain | (15 to 19 dBz) |
| Medium green | Rain | (20 to 29 dBz) |
| Dark Green | Rain | (30 to 39 dBz) |
| Yellow | Rain | (40 to 44 dBz) |
| Orange | Rain | (45 to 49 dBz) |
| Light red | Rain | (50 to 54 dBz) |
| Dark red | Rain | (55+ dBz) |
| Light blue | Snow | (5 to 19 dBz) |
| Dark blue | Snow | (20+ dBz) |
| Light pink | Mixed | (5 to 19 dBz) |
| Dark pink | Mixed | (20+ dBz) |

| Color code | Intensity in mm per hour |
|------------|--------------------------|
| Dark green | 4.01 to 12.00 mm/hr |
| Yellow | 12.01 to 24.00 mm/hr |
| Orange | 24.01 to 50.00 mm/hr |
| Light red | 50.01 to 100 mm/hr |
| Dark red | 100.01+ mm/hr |

Canadian radar precipitation color codes

Canadian radar shows the intensity of precipitation for Canada. Unlike NOWRad, Canadian radar does not show the precipitation type.

| Color code | Intensity in mm per hour |
|---|--------------------------|
| Transparent (nothing shown at very low precipitation) | 0.00 to 0.20 mm/hr |
| Light green | 0.21 to 1.00 mm/hr |
| Medium green | 1.01 to 4.00 mm/hr |

15.5 Weather map navigation

You can move around the weather map and place waypoints.

When you open the weather application, a world map is displayed. If the system has a position fix for your boat, the map will be centred on your boat. As in the chart application, use the cursor to move around the map and view different locations, and the Range control to zoom in and out. Use the **WPTS MOB** button to place waypoints.

Re-centering your vessel on the weather map

In the weather application:

1. Press the **FIND SHIP** softkey.

15.6 Weather reports

You can view a number of different weather reports to give you a comprehensive view of the weather.

Your multifunction display shows weather reports for:

- Tropical statements.
- Marine warnings.
- Marine zone forecasts.
- Marine watchbox warnings.

Tropical statements

Tropical statements provide information on tropical weather conditions. This information may not be available in all areas.

Marine warnings

You can display a report for the current marine warnings in the US coastal or near shore areas, or for the zone around your cursor or vessel.

Marine zone forecasts

These forecasts cover:

- US Coastal Weather Forecasts and Offshore Forecasts and High Seas Forecast, or
- Great Lakes Forecast and Near Shore Forecast, or
- Canadian Coastal Weather Forecast.

Marine watchbox warnings

When a tornado or thunderstorm warning is received within the specified range of your vessel (**MENU** > Weather Setup Menu > Marine Watchbox Alerts), the system generates a watchbox alert. This alert provides information on the type of warning and validity period. The full watchbox report text is also displayed.

Displaying weather reports

In the weather application:

1. Press the **WEATHER REPORTS** softkey.
2. Select the **TROPICAL STATEMENTS, MARINE WARNINGS, MARINE ZONE FORECASTS, or WATCHBOX WARNINGS** softkey, as appropriate.

The relevant report, warning, or statement is displayed.

Changing the position of forecasts on the weather map

In the weather application:

1. Press the **WEATHER REPORTS** softkey.
2. Press the **FORECAST AT** softkey until the **CURSOR** or **SHIP** option is selected, as appropriate.

Note: You cannot change the position of **TROPICAL STATEMENTS** or **WATCHBOX WARNINGS**.

15.7 Storm tracking

The storm tracking function enables you to monitor significant storms in the area.

Examples of significant storms include tropical disturbances, depressions, storms and cyclones, hurricanes, typhoons, and super typhoons.

The weather map displays the track that the storm has taken, its current and forecasted position, the wind radii (current position only), direction, and speed of travel.

Storm tracks are highlighted on the weather map in the form of symbols, as shown below.

When you move the cursor over a symbol, additional storm information is displayed.

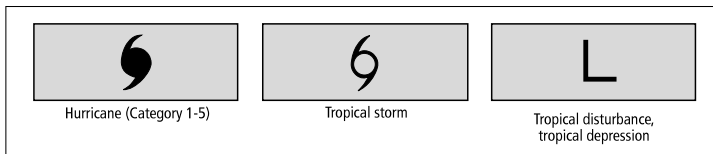

15.8 Animated weather graphics

You can view animated weather graphics to provide an indication of changing weather patterns.

The animated weather option enables you to view an animation from the current time for:

- The forecast for wind, wave, or surface pressure.
- The weather radar history loop (NOWRad).

Running a weather animation

In the weather application:

1. Press the **ANIMATE WEATHER** softkey.
2. Press the **ANIMATE TYPE** softkey until the F'CAST (forecast) or N'RAD (NOWRad) option is selected, as appropriate.
3. If the F'CAST option is selected, press the **FORECAST** softkey until the WIN (wind), WAV (waves), or PRES (pressure) option is selected, as appropriate.
4. Press the **ANIMATE** softkey until the ON option is selected.
5. Press the **OK** button.

Note: You cannot display information (by moving the cursor over a symbol) when animation is running. The range and trackpad controls do however remain operable provided the PAUSE option has not been selected. Ranging /panning will cause the animation to restart.

Note: The animation will be switched to OFF, whenever the **ACTIVE**, **PAGE**, **DATA**, **WPTS MOB**, or **MENU** buttons are pressed, or when the animation screen is closed and you return to the default weather screen.

Chapter 16: Using Sirius satellite radio (North America only)

Chapter contents

- [16.1 Sirius radio overview on page 216](#)
- [16.2 Displaying the Sirius radio application on page 216](#)
- [16.3 Sirius radio basic operations on page 217](#)
- [16.4 Sirius radio presets on page 218](#)
- [16.5 Favorite Sirius radio song alerts on page 219](#)
- [16.6 Sirius radio parental locking on page 220](#)

16.1 Sirius radio overview

You can use your multifunction display to control a connected Sirius Satellite Radio receiver.

Your multifunction display provides access to basic and advanced audio functions on a connected Sirius Satellite Radio receiver.

The Sirius Satellite Radio service is only available in North America.

From your multifunction display, you can:

- Tune to a Sirius radio channel.
- Browse a Sirius radio channel without tuning to it.
- Scan for Sirius radio channels (tune to all channels in turn).
- Set up Sirius radio presets for fast access to commonly used channels.
- Set up a parental lock on a Sirius radio channel.
- Receive alerts for favorite songs and artists.

Multiple applications

With most applications, it is possible to run 4 instances of the same application at any one time. However there are 2 exceptions to this, which are:

- **Chart application** — maximum 2 simultaneous instances per multifunction display.
- **Sirius satellite radio application** — maximum 1 instance per multifunction display, at any one time.
- **Video application** — maximum 1 instance per multifunction display, at any one time.

16.2 Displaying the Sirius radio application

With the home screen displayed:

1. Select a page that includes the Sirius Satellite Radio application.

The Sirius Satellite Radio application is displayed:

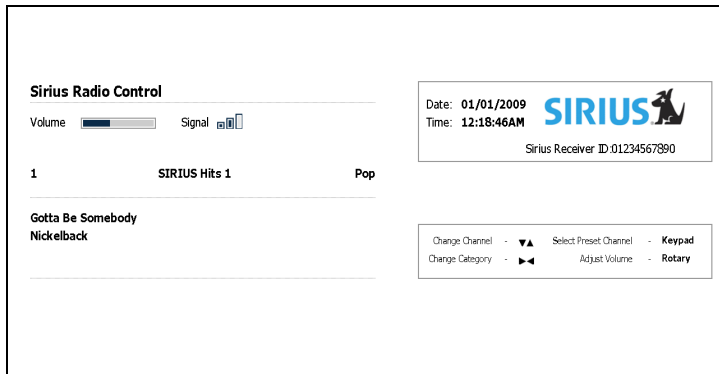

16.3 Sirius radio basic operations

You can tune, browse, and scan Sirius Radio channels using your multifunction display.

Tuning and browsing

You can tune to a channel using the following methods:

- using the trackpad, you can tune to the previous or next channel sequentially, or the first channel in the previous or next category;
- using the browse function (ALL or PRESET) to locate a channel with the trackpad or rotary control, and then the **TUNE TO CHANNEL** softkey to listen.

Scanning

The scanning function automatically tunes to all channels in turn.

Tuning to a Sirius radio channel

In the Sirius Satellite Radio application:

1. Press the trackpad up to tune to the next available channel.
2. Press the trackpad down to tune to the previous channel.
3. Press the trackpad right to tune to the first channel in the next category.
4. Press the trackpad left to tune to the first channel in the previous category.

Browsing Sirius radio channels

In the Sirius Satellite Radio application:

1. Select the **BROWSE** softkey.
The Channel List or Preset List is displayed.
2. Using the trackpad, scroll through the available channels.
3. Select the **TUNE TO CHANNEL** softkey to listen to the selected channel.

Scanning Sirius radio channels

In the Sirius Satellite Radio application:

1. Select the **SETUP CHANNELS** softkey.
2. Select the **SCAN CHANNELS** softkey.
3. Select the **SCAN ALL/PRE** softkey to scan all channels, or only preset channels.
4. Use the **SELECT** softkey to stop the scan at anytime and listen to the active channel.

Showing or hiding Sirius radio channels

In the Sirius Satellite Radio application:

1. Select the **SETUP CHANNELS** softkey.
2. Select the EDIT CHANNEL ACCESS option.
3. Select the channel you want to hide.
4. Select the **CHANNEL SHOWN** and **CHANNEL HIDDEN** softkeys to toggle between SHOW and HIDE.

16.4 Sirius radio presets

You can assign up to 18 Sirius Radio channels to presets to make it easier to find commonly used channels.

Each channel must be assigned to a different preset. You can also move channels between presets, and delete existing presets.

The following screenshot shows the Sirius Radio Preset List:

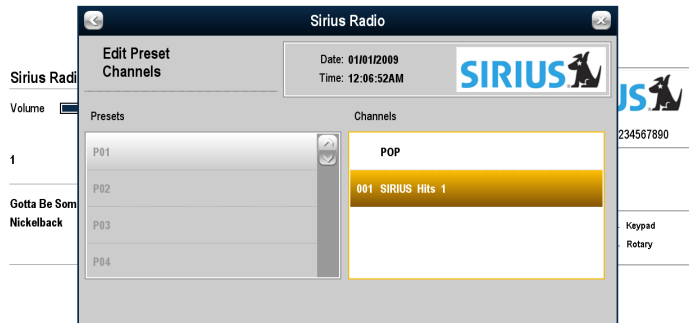

2. Select the preset you want to delete the channel from.
3. Select the **DELETE CHANNEL** softkey.

Moving a Sirius radio channel to another preset

In the Sirius Satellite Radio application:

1. Select the **PRESETS** softkey.
The Preset List is displayed.
2. Select the preset that contains the channel you want to move.
3. Select the **MOVE TO NEW PRESET** softkey.
4. Select the preset you want to move the channel to.
5. Select the **MOVE TO NEW PRESET** softkey.

Assigning Sirius radio channel presets

In the Sirius Satellite Radio application:

1. Select the **PRESETS** softkey.
The Preset List is displayed.
2. Select an unused preset number from the Preset List.
3. Select the **ASSIGN NEW CHANNEL** softkey.
4. Select the target channel.

Deleting a Sirius radio channel from a preset

In the Sirius Satellite Radio application:

1. Select the **PRESETS** softkey.
The Preset List is displayed.

16.5 Favorite Sirius radio song alerts

The favorites feature alerts you when a favorite song or artist is playing on any Sirius Radio channel.

When favorite alerts are enabled and a favorite song or artist is played on any channel, an alert is displayed and an alarm sounds.

You can add a song or artist as a favorite when you hear it being played on a Sirius radio channel. You can then add an alert for it at that time, or at anytime in the future.

You can define up to 10 favorite songs or artists.

The following screenshot shows an example of a Sirius radio song alert:



2. Select the **ADD SONG** or **ADD ARTIST** softkey, as appropriate. The song or artist is added as a favorite.
3. If you want to add an alert for the song or artist at this time, use the **ALERTS ON/OFF** softkey to select the ON option.

Setting up Sirius radio favorite alerts

In the Sirius Satellite Radio application when your favorite song or artist is playing:

1. Select the **ALERTS** softkey.

The Edit Alerts dialog is displayed.

16.6 Sirius radio parental locking

You can block certain Sirius Radio channels to prevent unauthorized access.

When you enable the “Parental Locking” function, you can assign a password to a channel to restrict access to it.

Subsequently, it will not be possible to listen to the channel unless the correct password is entered first.

Setting up Sirius radio parental locking

In the Sirius Satellite Radio application:

1. Select the **SETUP CHANNELS** softkey.
2. Select the ON option for the **PARENTAL LOCK** softkey.
The Password Setup dialog is displayed.
3. Enter and confirm your password and hint.
4. Select SAVE.

Changing the Sirius radio password

In the Sirius Satellite Radio application:

1. Select the **SETUP CHANNELS** softkey.
2. Select the **EDIT CHANNEL ACCESS** softkey.
3. Select the **EDIT LOCKOUT PASSWORD** softkey.
4. Enter your old password.
5. Enter your new password and password hint.
6. Select SAVE.

Blocking a Sirius radio channel

In the Sirius Satellite Radio application:

1. Select the **SETUP CHANNELS** softkey.
2. Select the **EDIT CHANNEL ACCESS** softkey.
The Channel List is displayed.

3. Select the channel you want to block access to.
4. Select the LOCKED option with the **CHANNEL ENABLED/LOCKED** softkey.
5. Repeat Steps 3 to 4 for each channel you want to block.
6. Select the **CLEAR** softkey.
7. Select the ON option with the **PARENTAL LOCK** softkey.
8. At the prompt, enter your password.

Blocked channels remain visible in channel lists, but you cannot select them, and they are ignored by the scan function. Blocked channels are marked as locked by an icon next to the channel name.

Accessing a blocked Sirius radio channel

In the Sirius Satellite Radio application:

1. Select the **SETUP CHANNELS** or **BROWSE** softkey to find the blocked channel.
When you select a blocked channel, you are prompted for your password.
2. Enter your password.
3. Select the **OK** button.

If you enter an incorrect password more than 3 times, your password hint is displayed.

Chapter 17: Using Navtex

Chapter contents

- [17.1 Navtex overview on page 222](#)
- [17.2 Navtex setup on page 222](#)
- [17.3 Viewing and managing Navtex messages on page 223](#)

17.1 Navtex overview

The Navtex features enable you to view marine safety information, including weather forecasts and marine safety warnings.

With a suitable Navtex receiver connected to your multifunction display, you can view marine safety information, including weather forecasts and marine warnings.

Major areas of NAVTEX coverage include the Mediterranean Sea, The North Sea, coastal areas around Japan, and areas around the North American continent.

Incoming Navtex Message Alerts

Whenever a warning is received by the Navtex receiver, an alert is displayed on your multifunction display for any category of information that you have set up. The alert contains the message details, and can be erased or saved.

Your multifunction display stores up to 100 messages. Once capacity is reached, the oldest messages are automatically deleted to allow for new incoming messages.

Navtex Message Alert Categories

You can configure your multifunction display to show alerts for a range of different categories of information, including warnings, reports and services. Examples include navigational warnings, ice reports, search and rescue information, meteorological warnings, and special services.

These categories are set up using the Navtex Message List. Selecting the appropriate categories from the list ensures that you only receive warnings and information that are relevant to you.

17.2 Navtex setup

In order to receive Navtex alerts on your multifunction display, you must connect a Navtex receiver and configure the NMEA options on your multifunction display.

Before you are able to receive and view Navtex safety messages on your multifunction display, you must:

- Connect a suitable Navtex receiver to your multifunction display.
- Specify the appropriate baud rate for the relevant NMEA port on your multifunction display (MENU > System Setup > System Integration). You must select the Navtex 4800 or Navtex 9600 option if you want to view the Navtex Message List.
- Select the appropriate category of Navtex message that you want to receive alerts for.

17.3 Viewing and managing Navtex messages

Viewing a Navtex message

1. Display the Navtex Message List:
 - i. Press the **MENU** button.
 - ii. Select the NAVTEX MESSAGES menu item.

The Navtex message list is displayed.
2. Highlight the message in the list that you want to view.
3. For long messages, scroll the list to view the full message text.

Displaying the Navtex message list

1. Press the **MENU** button.
2. Select the NAVTEX MESSAGES menu item.

Sorting the Navtex message list

1. Display the Navtex Message List:
 - i. Press the **MENU** button.
 - ii. Select the NAVTEX MESSAGES menu item.

The Navtex message list is displayed.
2. Select the **SORT LIST** softkey and choose the DATE, STN (Station Identifier), or CAT (Category) option, as appropriate.

Selecting Navtex message alert categories

1. Display the Navtex Message List:
 - i. Press the **MENU** button.
 - ii. Select the NAVTEX MESSAGES menu item.
2. Select the **SETUP ALERTS** softkey.
3. Select the category that you want to receive alerts for.

4. Set the receive status to ON or OFF, as appropriate.
5. Repeat Steps 3 to 4 for each category, as appropriate.

Chapter 18: Using video

Chapter contents

- [18.1 Video application overview on page 226](#)
- [18.2 Using video on page 227](#)

18.1 Video application overview

You can view a video or camera source on your multifunction display.

The video application enables you to connect a video source directly to your multifunction display, and view the video on the screen.

With the optional audio / video cable accessory, you can connect up to 4 video sources to your multifunction display.

Although you can only view one video source at any one time, you can set up your multifunction display to cycle through up to 4 different video sources (for example, one video source every 10 seconds).

You can also adjust the brightness, contrast, color, and aspect ratio of each video source.

The following image shows an example of a camera feed displayed in the video application:

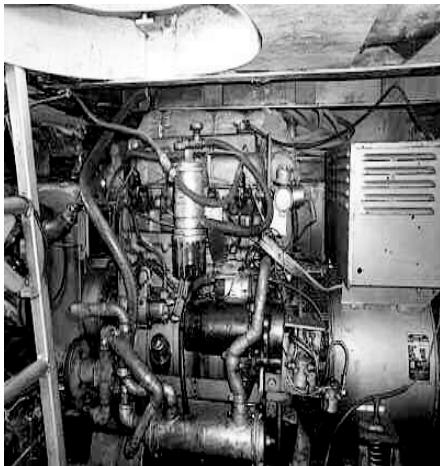

D/093_2

You can also output anything displayed on your multifunction display to an external display. The output resolution can be adjusted in the **MENU > Display Setup Menu**.

Note: You can only view the video on the multifunction display that the video source is directly connected to. You cannot view the video on any additional networked displays.

Note: For information on connecting the video source, compatible input configurations, and the optional audio / video cable accessory, refer to the Installation Guide.

18.2 Using video

Displaying the video application

1. Press the **HOME** button to display the home screen.
2. Select a page that includes the video application.
The video application is displayed.

Changing the video aspect ratio

In the video application:

1. Select the **PRESENTATION** softkey.
2. Use the **ASPECT RATIO** softkey to select the appropriate option.

Selecting video source input type

In the video application:

1. Press the **MENU** button.
2. Select **Video Setup**.
3. Select the video input that corresponds to the connected video source (for example, "Video 1").
4. Select **Type**.
5. Select the Composite or S-Video option, as appropriate.

Changing the video output resolution

1. Press the **MENU** button.
2. Select **Display Setup**.
3. Use the **Video Output Resolution** menu item to adjust the resolution.

Adjusting the video picture

In the video application:

1. Select the **PRESENTATION** softkey.
2. Select the **CONTRAST**, **BRIGHTNESS**, or **COLOR** softkey, as appropriate.
3. Using the trackpad, adjust the level as required.

Switching video sources

In the video application:

1. Select the **VIDEO 1**, **VIDEO 2**, **VIDEO 3**, or **VIDEO 4** softkey to view the relevant video source.

Cycling video sources

In the video application:

1. Select the **PRESENTATION** softkey.
2. Use the **CYCLE VIDEO** softkey to select the ON option.

Specifying the video source cycle order and period

In the video application:

1. Press the **MENU** button.
2. Select **Video Setup**.
3. Select **Cycle 1**, and select the video source that you want to use.
4. Repeat Step 3 for each video cycle.
5. Select **Cycle Period**, and use the rotary control to enter the number of seconds that should elapse between each video source cycle.
6. Press the **OK** button.

Chapter 19: Using the thermal camera application

Chapter contents

- [19.1 Thermal camera application overview on page 230](#)
- [19.2 Camera control on page 231](#)
- [19.3 Image adjustments on page 233](#)
- [19.4 Camera setup on page 236](#)

19.1 Thermal camera application overview

The thermal camera application enables you to control a connected thermal camera and display its image on your multifunction display.

Thermal imaging (also known as infrared) cameras enable you to see clearly in low-light and no-light conditions. For example, a thermal camera can help you navigate at night or identify obstacles in areas of low visibility or even total darkness.

The thermal application enables you to:

- **Control the camera:**

- Pan.
- Tilt.
- Zoom (range).
- Return camera to “home” (default) position.
- Set the camera “home” position.
- Pause the camera image.
- Toggle between visible light and thermal camera lenses.
- Toggle surveillance mode.

- **Adjust the camera image:**

- Color palette.
- Scene presets.
- Aspect ratio.
- Brightness.
- Contrast.
- Color.
- Video polarity (reverse video color).

Displaying the thermal camera application





With the home screen displayed:









1. Select a page icon that includes the thermal camera application.
The thermal camera application is displayed.

Note: If the home screen does NOT include a page icon that features the thermal camera application you will need to create a new page icon featuring the thermal camera application.

Thermal camera status icons

The thermal camera image includes icons to show the current status of the camera.

| Icon | Description |
|--|---|
|  | Camera direction indicator. |
|  | Camera home position. |
|  | Scene preset mode for night conditions. |
|  | Scene preset mode for daytime conditions. |
|  | Scene preset mode for night docking. |

| Icon | Description |
|--|---|
|  | Scene preset mode for identifying people or objects in the water. |
|  | Rear-view mode — image is flipped horizontally. |
|  | Zoom setting: 2x zoom. |
|  | Zoom setting: 4x zoom. |
|  | Image paused. |
|  | Single active controller on network. |
|  | Multiple active controllers on network. |
|  | PC / laptop detected on network. |

19.2 Camera control

Thermal camera standby

Standby mode can be used to temporarily suspend the thermal camera's functions when the camera is not needed for a prolonged period.

When in standby mode the camera:

- Does NOT provide a live video image.
- Moves the camera into its “stowed” (parked) position (lens facing down into the camera base) to protect the camera optics.
- Engages its pan / tilt motors to hold the camera in place in rough seas.

Note: The “stowed” (parked) position can be configured using the camera's setup menu.

Enabling and disabling thermal camera standby

In the thermal camera application:

1. Select the **OPTIONS** softkey.
2. Use the **CAMERA STANDBY** softkey to select ON or OFF option, as appropriate.

Note: You can also use any of the camera controls in the thermal camera application to “wake” the camera from standby mode.

Panning, tilting, and zooming the thermal image

There are 2 ways of controlling the thermal camera using the thermal application:

- Using the touchscreen and Range key.
- Using the UniControl and Range key.

You can pan and tilt the thermal camera using touch actions:

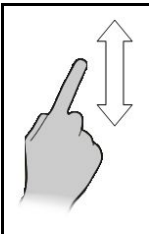
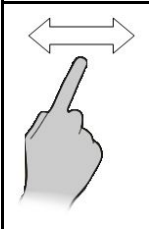
| | |
|--|--|
|  | <p>Move your finger up and down the screen to tilt the camera up or down.</p> |
|  | <p>Move your finger left and right on the screen to rotate the camera left or right (panning).</p> |

Note: You cannot zoom the thermal camera image using the touchscreen. You must use the multifunction display's Range key (see below), or the thermal camera's optional Joystick Control Unit (JCU).

You can also use a combination of the UniControl and range keys to manipulate the thermal camera view. This method is ideal for finer control over the camera and is particularly useful in rough sea conditions.

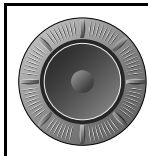
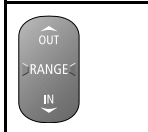
| | |
|---|--|
|  | <p>UniControl — is used for rotating the camera left or right (panning), or tilting the camera up or down.</p> |
|  | <p>Range key— is used to zoom in and out.</p> |

Thermal camera home position

The home position is a preset position for the camera.

The home position usually defines a useful reference point — for example, straight ahead and level with the horizon. You can set the home position as required and to return the camera to the home position at any time.

| | |
|---|--|
|  | <p>The home icon appears on-screen momentarily when the camera returns to the home position. The icon flashes when a new home position is set.</p> |
|---|--|

Resetting the thermal camera to the home position

In the thermal camera application:

1. Select the **CAMERA HOME** softkey.

The camera returns to its currently defined home position, and the “Home” icon appears on-screen momentarily.

Setting the thermal camera home position

In the thermal camera application:

1. Use the trackpad or rotary control to move the camera to the desired position.

- Hold the **CAMERA HOME** softkey for 3 seconds.
The “Home” icon flashes on-screen to indicate that a new home position has been set.

Pausing the thermal camera image

In the thermal camera application:

- Select the **OPTIONS** softkey.
- Select the **CAMERA MODES** softkey.
- Select the **PAUSE IMAGE** softkey.

Thermal camera surveillance mode

In surveillance mode the camera pans left and right continuously.

The camera continues to pan until surveillance mode is disabled, or the JCU (Joystick Control Unit) or thermal camera application controls are used to move the camera. When this occurs the camera does not automatically resume surveillance mode and the mode must be enabled again if required.

Enabling and disabling thermal camera surveillance mode



In the thermal camera application:

- Select the **OPTIONS** softkey.
- Select the **CAMERA MODES** softkey.
- Use the **SURVEILLANCE MODE** softkey to select the ON or OFF option, as appropriate.

19.3 Image adjustments

Thermal and visible-light operation

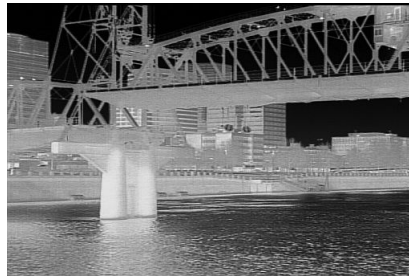
“Dual payload” thermal cameras are equipped with 2 camera lenses — a thermal imaging (infrared) camera lens and a visible-light camera lens.

| | |
|--|---|
|  | <p>Thermal camera lens — provides night-time imagery, based on temperature differences between objects. Thermal imaging produces a clear image even in total darkness.</p> |
|  | <p>Visible-light camera lens — provides black and white (or greyscale) imagery during the day and in low-light conditions. Helps to improve navigational abilities in low-light conditions; for example during twilight hours when operating along intercoastal waterways and near harbor entrances.</p> |

Switching between thermal and visible-light camera lenses

In the thermal camera application:

- Use the **THERMAL / VISIBLE** softkey to switch between the 2 camera lenses.

Note: Only “dual payload” thermal cameras feature the ability to switch between thermal and visible light. The camera’s “VIS / IR” video cable must be connected to your system if you want to switch between the 2 camera lenses.

Changing the thermal video aspect ratio

In the thermal camera application:

1. Select the **OPTIONS** softkey.
2. Select the **PRESENTATION** softkey.
3. Use the **ASPECT RATIO** softkey to select the Auto, 4:3, or 16:9 option, as appropriate.

Adjusting the thermal camera image





In the thermal camera application:

1. Select the **OPTIONS** softkey.
2. Select the **PRESENTATION** softkey.
3. Select the **CONTRAST**, **BRIGHTNESS**, or **COLOR** softkey, as appropriate.
4. Using the trackpad, adjust the level as required.

Thermal camera scene presets

Scene presets enable you to quickly select the best image setting for the current environmental conditions.

During normal operation the thermal camera automatically adjusts itself to provide a high-contrast image optimized for most conditions. The Scene presets provide 4 additional settings that may provide better imagery in certain conditions. The 4 modes are:

| | |
|---|---|
|  | Night Running — scene preset mode for night conditions. |
|  | Day Running — scene preset mode for daytime conditions. |
|  | Night Docking — scene preset mode for night docking. |
|  | Search — scene preset mode for identifying people or objects in the water. |

Although the preset names indicate their intended use, varying environmental conditions might make another setting more preferable. For example, the night running scene preset might also be useful while in a harbor. You may find it beneficial to experiment with the different scene presets to discover the best preset to use for different conditions.

Changing the thermal camera scene preset

In the thermal camera application:

1. Use the **SCENE** softkey to switch between the available scene modes.

The “scene” icon changes to reflect the current scene mode.

Thermal camera color modes

A range of color modes is available to help you distinguish objects on-screen in different conditions.

The **COLOR** softkey switches the thermal camera image between a greyscale mode and 1 or more color modes. There are 5 color modes available.

The factory default color mode is red, which may improve your night vision. This default mode can be changed if required using the camera's **Video Setup** menu.

Note: If you have the Disable Color Thermal Video option selected in the camera's **Video Setup** menu, only 2 color modes are available — greyscale and red.

Changing the thermal camera color mode

In the thermal camera application:

1. Use the **COLOR** softkey to switch between the available color modes.

Thermal camera reverse video

You can reverse the polarity of the video image to change the appearance of objects on-screen.

The reverse video option (video polarity) switches the thermal image from white-hot (or red-hot if the color mode setting is active) to black-hot. The difference between white-hot and black-hot is shown below:

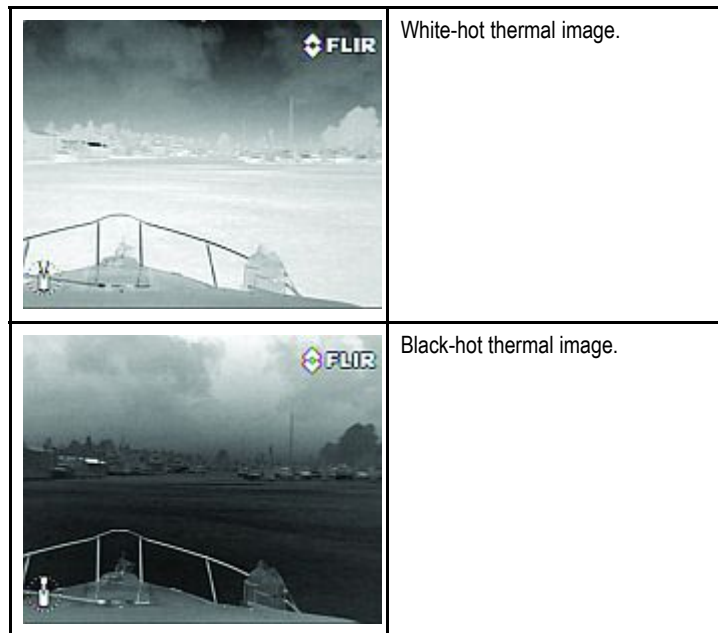

You may find it useful to experiment with this option to find the best setting to suit your needs.

Enabling thermal camera reverse video

In the thermal camera application:

1. Select the **OPTIONS** softkey.
2. Use the **REVERSE VIDEO** softkey to switch the video polarity.

Thermal camera rear view mode

The rear view mode flips the video image horizontally, providing a “mirror image”.

This is useful for example in instances where the camera is rear-facing and you are viewing the image on a forward-facing monitor.

Enabling and disabling thermal camera rear view mode

In the thermal camera application:

1. Select the **OPTIONS** softkey.
2. Select the **CAMERA MODES** softkey.
3. Use the **REAR VIEW** softkey to select the ON or OFF option, as appropriate.

19.4 Camera setup

Accessing the thermal camera setup menu

The thermal camera menu provides access to the camera’s configuration options.

In the thermal camera application:

1. Select the **OPTIONS** softkey.
2. Select the **CAMERA MENU** softkey.

Note: For instructions on using the thermal camera’s setup menu refer to the documentation that accompanies the camera.

Chapter 20: DSC VHF radio integration

Chapter contents

- [20.1 Using a DSC VHF radio with your display on page 238](#)
- [20.2 Enabling DSC VHF radio integration on page 239](#)

20.1 Using a DSC VHF radio with your display

You can connect your DSC VHF radio to your multifunction display and show distress message information and GPS position data for other vessels.

Connecting a DSC VHF radio to your multifunction display provides the following additional functionality:

- **Distress Messages** — when your DSC VHF radio receives a DSC message or alarm from another DSC VHF radio-equipped vessel, the vessel identification (MMSI), GPS position, and time of distress message is displayed on your multifunction display. You can use the softkeys on your multifunction display to clear the message, place a waypoint on the chart at the GPS position of the distressed vessel, or immediately start navigating (GOTO) to the GPS position.
- **Position Data** — the “Position Request” button on your DSC VHF radio enables you to send and receive GPS position data to and from other vessels equipped with a DSC VHF radio.

For information on installing and operating your DSC VHF radio, refer to the handbook that accompanies the radio.

The following image shows an example of a distress message displayed on a multifunction display:

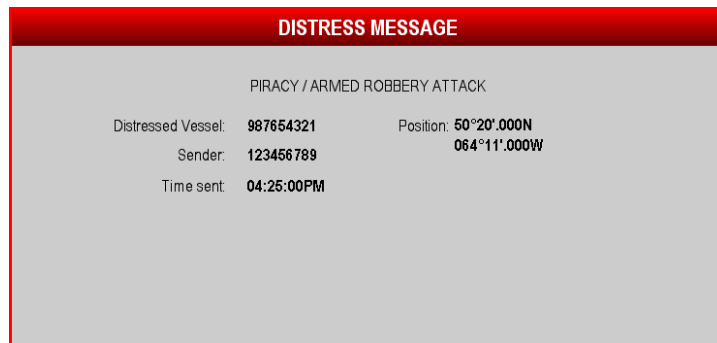

20.2 Enabling DSC VHF radio integration

To configure your multifunction display to show messages from your DSC VHF radio:

1. Press the **MENU** button.
2. Select the **System Setup** menu item.
3. Select the **System Integration** menu item.
4. Select the ON option for the **DSC Message** menu item.
5. Press the **OK** button.

Chapter 21: Customizing your display





Chapter contents

- [21.1 Customizing the vessel icon on page 242](#)
- [21.2 Customizing the databar on page 242](#)
- [21.3 GPS setup on page 243](#)
- [21.4 System setup menu on page 245](#)

21.1 Customizing the vessel icon

In the chart application:

1. Press the **MENU** button.
2. Select **Chart Setup**.
3. Select **Vessel Icon Type**
4. Select the Sail or Power option, as appropriate.
5. Select **Vessel Icon Size**.
6. Select Small Static or Large Static, as appropriate.

| Vessel icon | Vessel type | Chart view |
|---|----------------------|------------|
|  | Power / Sail — small | 2D / 3D |
|  | Power — large | 2D |
|  | Power — large | 3D |
|  | Sail — large | 2D |
|  | Sail — large | 3D |

21.2 Customizing the databar

Moving the databar

1. Press the **DATA** button.
2. Press and hold the **DATABAR** softkey until the Database Setup Menu dialog is displayed.
3. Using the trackpad, select the Position menu item.
4. Using the trackpad, select the Top or Side option, as appropriate.
5. Press the **OK** button.

Changing the data displayed in the databar

1. Select the Databar Setup Menu:
 - i. Press the **MENU** button.
 - ii. Select **Databar Setup**.
The Databar Setup Menu is displayed.
2. To add data to the databar:
 - i. With the Databar Setup Menu displayed, select the **Configure** menu item.
A red border will appear in the databar, identifying the currently selected item.
 - ii. Using the trackpad, select the desired position in the databar for the new data.
 - iii. Select the **ADD DATA** softkey.
 - iv. Select the data group that contains the type of data you want to add.
 - v. Select a data element from the data group.
 - vi. Select an appropriate data type for the data.
 - vii. Press the **OK** button.
3. To move data in the databar:

21.3 GPS setup

The GPS setup options enable you to configure a connected GPS receiver.

The Global Positioning System (GPS) is used to position your vessel on the chart. You can set up your GPS receiver and check its status from the GPS Status option in the Setup Menu. For each tracked satellite, this screen provides the following information:

- Satellite number.
- Signal strength bar.
- Status.
- Azimuth angle.
- elevation angle.
- A sky-view to show the position of tracked satellites.

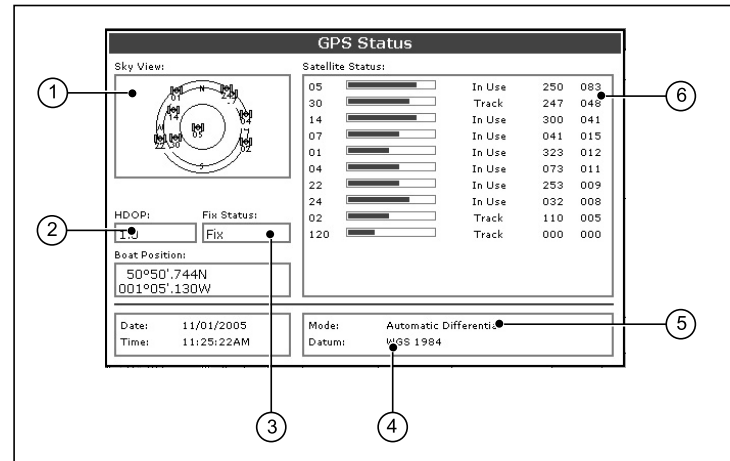

- With the Databar Setup Menu displayed, select the **Configure** menu item.
A red border will appear in the databar, identifying the currently selected item.
 - Select the **MOVE DATA** softkey.
 - Using the trackpad, move the item of data to the desired position in the databar.
 - Press the **OK** button.
4. To remove a data item from the databar:
- With the Databar Setup Menu displayed, select the **Configure** menu item.
A red border will appear in the databar, identifying the currently selected item.
 - Using the trackpad, highlight the data item that you want to remove.
 - Select the **REMOVE DATA** softkey.

| Item | Description |
|------|--|
| 1 | Sky view — a visual representation of the position of tracked satellites. |
| 2 | Horizontal Dilution of Position (HDOP) — a measure of GPS accuracy, calculated from a number of factors including satellite geometry, system errors in the data transmission and system errors in the GPS receiver. A higher figure signifies a greater positional error. A typical GPS receiver has an accuracy of between 5 and 15 m. As an example, assuming a GPS receiver error of 5 m, an HDOP of 2 would represent an error of approximately 15 m. Please remember that even a very low HDOP figure is NO guarantee that your GPS receiver is providing an accurate position. If in doubt, check the displayed vessel position in the chart application against your actual proximity to a known charted object. |
| 3 | Fix status — indicates the actual mode the GPS receiver is reporting (No Fix, Fix, D Fix or SD Fix). |
| 4 | Datum — The GPS receiver's datum setting affects the accuracy of the vessel position information displayed in the chart application. In order for your GPS receiver and multifunction display to correlate accurately with your paper charts, they must be using the same datum. Refer to the Using the Chart chapter for more information. |
| 5 | Mode — the mode currently selected by the GPS receiver. |
| 6 | Satellite status — displays the signal strength and status of each satellite identified in the Sky view diagram on the left of the screen. |

The accuracy of the GPS receiver depends on the parameters detailed above, especially the azimuth and elevation angles which are used in triangulation to calculate your position.

21.4 System setup menu

The following table describes the various options in the System Setup menu for your multifunction display.

| Menu item | Description | Options |
|------------------------|--|--|
| Boat Details | The accurate operation of the collision alarm is dependent on you supplying suitable values for the Boat Details setting. You should specify the minimum safe depth, beam, and height for your vessel. The values you specify MUST be appropriate for safe navigation, and must also take into account the position of the GPS antenna on your vessel, as the collision alarm uses data from the GPS antenna. | <ul style="list-style-type: none"> • Minimum Safe Depth • Minimum Safe Beam • Minimum Safe Height |
| Position Mode | Determines how positioning data is displayed — as Latitude / Longitude coordinates, or Loran TDs. | <ul style="list-style-type: none"> • Lat / Long (default) • TDs |
| TD Setup | When the Position Mode (see above) is set to TDs, you can specify the chain identifier, slave, and ASF values. | <p>Chain</p> <ul style="list-style-type: none"> • Various options, depending on cartography. <p>Slave 1/2</p> <ul style="list-style-type: none"> • Various options, depending on cartography. <p>ASF 1/2</p> <ul style="list-style-type: none"> • -09.9 to +09.9 |
| Simulator | Enables or disables simulator mode, which allows you to practice operating your multifunction display without data from a GPS antenna, fishfinder (DSM sonar), or any other external unit. | <ul style="list-style-type: none"> • OFF (default) • ON • DEMO |
| Simulator Speed | Enables you to specify the speed at which the vessel icon will move when the Simulator mode is enabled (see above). | <ul style="list-style-type: none"> • 1x • 2x • 3x |

| Menu item | Description | Options |
|--------------------------|---|--|
| Bearing Mode | Determines how all bearing and heading data is displayed in. This does not affect how the chart or radar displays are drawn. | <ul style="list-style-type: none"> • True (default) • Magnetic |
| MOB Data Type | Determines whether positional data or dead reckoning is displayed. Assuming that your vessel and the Man Overboard (MOB) are subject to the same tide and wind effects, the dead reckoning setting normally gives a more accurate course. | <ul style="list-style-type: none"> • Dead Reckoning • Position (default) |
| Variation Source | This setting compensates for the naturally occurring offset of the earth's magnetic field. When set to Auto, the system automatically compensates, and displays the compensation value in brackets. To enter your own compensation value, use the Manual option, then specify the value using the Manual Variation setting (see below). | <ul style="list-style-type: none"> • Auto (compensation value displayed in brackets) (default) • Manual |
| Manual Variation | When the Variation Source menu item is set to Manual (see above), you use the Manual Variation setting to specify the compensation value that you want to use. This value is also transmitted to any other connected Raymarine instruments. | <ul style="list-style-type: none"> • 0 degrees East (default) • Range: 0 to 30 degrees East or West • |
| Language | Determines the language that will be used for all on-screen text, labels, menus and options. | |
| Ground Trip Reset | Resets the chosen ground trip distance counter to zero. | <ul style="list-style-type: none"> • Ground Trip 1 Reset • Ground Trip 2 Reset • Ground Trip 3 Reset • Ground Trip 4 Reset |
| Settings Reset | Resets all system setup menus, including page sets and the databar, to the factory default settings. Waypoints, routes and tracks are NOT deleted. | <p>Reset Defaults confirmation</p> <ul style="list-style-type: none"> • YES • NO |

| Menu item | Description | Options |
|--------------------------------|---|--|
| Settings and Data Reset | <p>Resets all system setup menus, including page sets and the databar, to the factory default settings. Waypoints, routes and tracks ARE deleted.</p> <div style="border: 1px solid black; padding: 5px; margin: 5px 0;"> <p>Note: For systems using multiple multifunction displays (networked displays), the complete system database is deleted on the data master (primary display). Only the waypoints, routes and tracks will be deleted from any additional multifunction displays.</p> </div> <div style="border: 1px solid black; padding: 5px; margin: 5px 0;"> <p>Note: If this reset function is performed on a G-Series system it will also delete your Nav Station settings.</p> </div> | <p>Factory Reset confirmation</p> <ul style="list-style-type: none"> • YES • NO |
| Time / Date Setup | <p>These options enable you to customize the time and date format to your requirements. You can also specify a local time offset from Universal Time Constant (UTC), to compensate for any time zone difference.</p> | <p>Date Format</p> <ul style="list-style-type: none"> • mm/dd/yy • dd/mm/yy <p>Time Format</p> <ul style="list-style-type: none"> • 12 hr • 24 hr <p>Local Time Offset</p> <ul style="list-style-type: none"> • -013.0 to +013.0 |

| Menu item | Description | Options |
|--------------------|---|--|
| Units Setup | <p>Enables you to specify the units used for the following key measurements:</p> <ul style="list-style-type: none"> • Distance • Speed • Depth • Temperature • Pressure • Volume <div style="border: 1px solid black; padding: 5px; margin-top: 10px;"> <p>Note: If the Distance unit is set to Nautical Miles or Statute Miles, and the data displayed is less than 1 unit, the system displays the units in Feet. If the Distance unit is set to Kilometers, the system displays the units in Meters.</p> </div> | <p>Distance Units</p> <ul style="list-style-type: none"> • Nautical Miles (default) • Statute Miles • Kilometers <p>Speed Units</p> <ul style="list-style-type: none"> • Knots (default) • mph (miles per hour) • kph (kilometers per hour) <p>Depth Units</p> <ul style="list-style-type: none"> • Meters • Feet (default) • Fathoms <p>Temperature Units</p> <ul style="list-style-type: none"> • Fahrenheit (default) • Celsius <p>Pressure Units</p> <ul style="list-style-type: none"> • Bar • PSI (default) • Kilopascals <p>Volume Units</p> <ul style="list-style-type: none"> • US Gallons • Imp (Imperial) Gallons (default) |

| Menu item | Description | Options |
|---------------------------|---|---|
| | | <ul style="list-style-type: none"> • Liters |
| System Integration | <p>Determines the connection settings for external equipment. The following items are available in the sub-menu:</p> <ul style="list-style-type: none"> • Autopilot Control — If set to Enabled, this option allows you to control certain aspects of a connected pilot control head, such as sending commands to engage and disengage the autopilot. If set to Disabled, you will not be able to control the autopilot from your multifunction display, and all functions must be controlled from the pilot control head itself. • DSC Message — If set to ON, details of distress DSC messages from a connected DSC VHF radio will be displayed on your multifunction display. If set to OFF, the messages will NOT be displayed on your multifunction display. • SeaTalk Alarms — If set to ON, all system alarms generated by any connected SeaTalk units will be displayed on your multifunction display. If set to OFF, the alarms will NOT be displayed on your multifunction display. • Preferred GPS Source — Your multifunction display supports GPS receivers connected by SeaTalk1, SeaTalk^{ng}, or NMEA2000. Select the preferred source. • Data Master — If you have more than one multifunction display on the same network, one of them must be set as the data master. When this option is set to ON, the multifunction display you are currently using will be set as the data master. • Bridge NMEA Heading — If set to ON, NMEA heading data will be bridged onto the SeaTalk data bus, and will be sent to all NMEA-connected devices. If set to OFF, NMEA heading data will NOT be bridged onto the SeaTalk bus. An example of a use for this setting is when using MARPA with an external fast heading sensor, in which case you should set this option | <p>Autopilot Control</p> <ul style="list-style-type: none"> • Disabled (default) • Enabled <p>DSC Message</p> <ul style="list-style-type: none"> • OFF • ON (default) <p>SeaTalk Alarms</p> <ul style="list-style-type: none"> • ON (default) • OFF <p>Preferred GPS Source</p> <ul style="list-style-type: none"> • SeaTalkng / NMEA2000 (default) • SeaTalk1 • NMEA0183 <p>Data Master</p> <ul style="list-style-type: none"> • ON (default) • OFF <p>Bridge NMEA Heading</p> <ul style="list-style-type: none"> • OFF (default) • ON <p>Keyboard</p> |

| Menu item | Description | Options |
|-----------|--|--|
| | <p>to OFF to ensure that all NMEA-connected units receive heading data from the external heading sensor.</p> <ul style="list-style-type: none"> • Keyboard — Set to ONE or ALL if you have an external keyboard connected. Otherwise, set to OFF. • NMEA Output Setup — allows you to enable or disable the individual NMEA output “sentences” for each NMEA port. • NMEA Port Setting — Allows you to specify the appropriate port speed for the equipment connected to each NMEA port. When the Navtex 4800 or Navtex 9600 option is selected, you will be able to view the Navtex message list. Use the AIS 38400 option for AIS receivers. | <ul style="list-style-type: none"> • OFF • ALL (default) • ONE <p>NMEA Output Setup</p> <ul style="list-style-type: none"> • APB • BWC • BWR • DBT • DPT • GGA • GLL • GSA • MTW • MWV • RMA • RMB • RMC • RSD • RTE • TTM • VHW • VLW |

| Menu item | Description | Options |
|--------------------------------|---|--|
| | | <ul style="list-style-type: none"> • WPL • VTG • ZDA <p>NMEA Port Setting</p> <ul style="list-style-type: none"> • NMEA 4800 (default) • Navtex 4800 • Navtex 9600 • AIS 38400 |
| Waypoint Password Setup | This menu allows you to enable password protection for waypoints, and to change the password. | <p>Enable Password</p> <ul style="list-style-type: none"> • OFF (default) • ON <p>Change Password</p> <ul style="list-style-type: none"> • Displays Edit Waypoint Password dialog. |

Chapter 22: Maintaining your display

Chapter contents

- [22.1 Service and maintenance on page 254](#)
- [22.2 Routine equipment checks on page 254](#)
- [22.3 Cleaning on page 255](#)
- [22.4 Cleaning the display case on page 255](#)
- [22.5 Cleaning the display screen on page 256](#)

22.1 Service and maintenance

This product contains no user serviceable components. Please refer all maintenance and repair to authorized Raymarine dealers. Unauthorized repair may affect your warranty.

22.2 Routine equipment checks

Raymarine strongly recommends that you complete a number of routine checks to ensure the correct and reliable operation of your equipment.

Complete the following checks on a regular basis:

- Examine all cables for signs of damage or wear and tear.
- Check that all cables are securely connected.

22.3 Cleaning

Best cleaning practices.

When cleaning this product:

- Do NOT wipe the display screen with a dry cloth, as this could scratch the screen coating.
- Do NOT use abrasive, or acid or ammonia based products.
- Do NOT use a jet wash.

22.4 Cleaning the display case

The display unit is a sealed unit and does not require regular cleaning. If it is necessary to clean the unit, follow this basic procedure:

1. Switch off the power to the display.
2. Wipe the display with a clean, soft cloth (a microfibre cloth is ideal).
3. If necessary, use isopropyl alcohol (IPA) or a mild detergent to remove grease marks.

Note: Do NOT use IPA or any other solvent or detergent on the screen itself.

Note: In certain conditions, condensation may appear inside the display screen. This will not harm the unit, and can be cleared by powering on the display for a short time.

22.5 Cleaning the display screen

A coating is applied to the display screen. This makes it water repellent, and prevents glare. To avoid damaging this coating, follow this procedure:

1. Switch off the power to the display.
2. Rinse the screen with fresh water to remove all dirt particles and salt deposits.
3. Allow the screen to dry naturally.
4. If any smears remain, very gently wipe the screen with a clean microfibre cleaning cloth (available from an opticians).

Chapter 23: Technical support

Chapter contents

- [23.1 Raymarine customer support on page 258](#)
- [23.2 3rd party support on page 259](#)

23.1 Raymarine customer support

Raymarine provides a comprehensive customer support service. You can contact customer support through the Raymarine website, telephone and email. If you are unable to resolve a problem, please use any of these facilities to obtain additional help.

Web support

Please visit the customer support area of our website at:

www.raymarine.com

This contains Frequently Asked Questions, servicing information, e-mail access to the Raymarine Technical Support Department and details of worldwide Raymarine agents.

Telephone and email support

In the USA:

- **Tel:** +1 603 881 5200 extension 2444
- **Email:** Raymarine@custhelp.com

In the UK, Europe, the Middle East, or Far East:

- **Tel:** +44 (0)23 9271 4713
- **Email:** ukproduct.support@raymarine.com

Product information

If you need to request service, please have the following information to hand:

- Product name.
- Product identity.
- Serial number.
- Software application version.

You can obtain this product information using the menus within your product.

Viewing multifunction display software information

1. Press the **MENU** button.
2. Select **System Diagnostics**.
3. Select **Software Services**.
4. Select **Unit Info**.

A range of information is displayed, including the App Version (software version).

23.2 3rd party support

Contact and support details for 3rd party suppliers can be found on the appropriate websites.

Navionics

www.navionics.com

Sirius marine weather

www.sirius.com/marineweather

Sirius audio

www.sirius.com

Raymarine[®]
A FLIR COMPANY

www.raymarine.com

CE